

---

---

**AGENDA**  
**CUMBERLAND COUNTY BOARD OF COMMISSIONERS**  
**COURTHOUSE – ROOM 118**  
**NOVEMBER 17, 2008**  
**6:45 PM**

---

---

INVOCATION - Commissioner Breeden Blackwell, Chairman

PLEDGE OF ALLEGIANCE – Jacob Twaddell, Third Grade, Gallberry Elementary School

Special Recognition: Cumberland County Cares – Dr. Dawn Holt – Scarves for the Special Olympics

Recognition of Outgoing Board Member: William E. Tew, Jr., Farm Advisory Board

**PUBLIC COMMENT PERIOD (6:45 PM – 7:00 PM)**

1. Presentation by Mr. Jim Konneker, Chairman of the Local BRAC Project Committee.
2. Consent Agenda
  - A. Approval of minutes for the November 3, 2008 regular meeting.
  - B. Approval of Proposed Changes in the Health Department Vaccine Administration Fees.
  - C. Approval of Report on Formal Bid Awards Less than \$100,000 Approved by Management.
  - D. Approval of Assignment by Acquisition of Centerplate Food Services Concession Contract at the Cumberland County Crown Coliseum to Kohlberg & Company, LLC.
  - E. Budget Revisions:
    - (1) Health  
  
Breast and Cervical Cancer Control Program – Revision in the amount of \$34,637 to budget additional state funding. (B09-205) **Funding Source – State**

(2) Pre-Trial Release

Revision in the amount of \$10,000 to recognize revenue received from the City of Fayetteville for GPS program. (B09-206) **Funding Source - Miscellaneous**

(3) Emergency Addressing

Revision in the amount of \$2,500 to recognize revenue received from the Board of Education for web mapping software. (B09-212) **Funding Source – Miscellaneous**

(4) Information Services/Emergency Telephone System

Revision in the amount of \$63,095 to request new Server Systems Administrator position to be located in the Information Services Department to support the expanded requirements of the Emergency 911 system to be funded by State E911 funds. (B09-201 and B09-201A) **Funding Source – State**

(5) Emergency 911

Revision in the amount of \$24,050 to appropriate fund balance for additional digital logging recorder system. (B09-213) **Funding Source – Emergency 911 Fund Balance**

(6) Social Services

Revision in the amount of \$483,767 to recognize additional revenue for crisis intervention. (B09-218) **Funding Source – State**

F. Approval of Change Order G-2 for M&E Contracting – Life Safety Improvements For Ann Street Landfill Baling Facility.

3. Public Hearings

**Uncontested Cases**

Rezoning

A. Case P08-52. Rezoning of 1.64+/- acres from A1 Agricultural to R15 Residential, or to a more restrictive zoning district, located at 2463 Cedar Creek Road, submitted by Brady L. Rufenacht, owned by Watermark Homes Inc.

- B. Case P08-53. Rezoning of .55+/- acres from M(P) Planned Industrial/Conditional Use District ( to allow storage of explosive materials) and the Permit to A1 Agricultural, or to a more restrictive zoning district, located at 315 Magnolia Church Road, owned by Larry W. Hall.

**Conditional Use District Case**

**(Modifying previously approved “district” only, approved permit is not affected)**

- C. Case P08-54. Rezoning of .52+/- acres from MXD Mixed Use Development/CUD Conditional Use District & Permit to R7.5 Residential and R10 Residential to MXD Mixed Use Development/CUD Conditional Use District & Permit, or to a more restrictive zoning district, located on the south side of Elk Road, west of Pinewood Drive, owned by Fayetteville Christian Schools, Inc.

**Conditional Use District & Permit Case**

- D. Case P08-40. Rezoning of 0.81+/- acres from M(P) Planned Industrial/CUD Conditional Use District (to allow the manufacturing and sales of storage buildings) and the Permit to C(P) Planned Commercial, or to a more restrictive zoning district, located at 5003 Marracco Drive, owned by John D. Graham & Columbia O. Blanks.

Items of Business

- 4. Report and Recommendation of the Cumberland County Finance Committee.
- 5. Report on Parks & Recreation Bond Referendum and Funding Options for Joint Projects.
- 6. Nominations to Boards and Committees
  - A. Adult Care Home Community Advisory Committee (2 Vacancies)
  - B. Board of Health (3 Vacancies)
  - C. Fayetteville Area Convention & Visitors Bureau (2 Vacancies)
  - D. Human Relations Commission (1 Vacancy)
  - E. Mental Health Board (2 Vacancies)
  - F. Minimum Housing Appeals Board (1 Vacancy)
  - G. Nursing Home Advisory Board (1 Vacancy)
  - H. Transportation Advisory Board (2 Vacancies)

7. Appointments to Boards and Committees

A. Board of Adjustment (1 Vacancy)

Nominee:      Alternate Member:      William Lockett Tally

B. Cumberland County Emergency Planning Committee (1 Vacancy)

Nominee:

Operators of Facilities Representative:

Catherine Grazioli (Safety Manager – Hexion Specialty Chemicals)

8. Closed Session:                      A. Personnel Matter(s) Pursuant to  
NCGS 143-318.11(a)(6).

**ADJOURN**

**THIS MEETING WILL BE BROADCAST LIVE ON TIME WARNER COMMUNITY CHANNEL 7.**

**MEETINGS:                      December 1, 2008 (Monday) - 9:00 AM**  
**December 15, 2008 (Monday) - 6:45 PM**



ITEM NO. 1

## COUNTY of CUMBERLAND

James E. Martin  
County Manager

Cliff Spiller  
Assistant County Manager

Juanita Pilgrim  
Deputy County Manager

*Office of the County Manager*

Amy H. Cannon  
Assistant County Manager

### MEMORANDUM FOR BOARD OF COMMISSIONERS AGENDA OF NOVEMBER 17, 2008

**TO:** BOARD OF COUNTY COMMISSIONERS

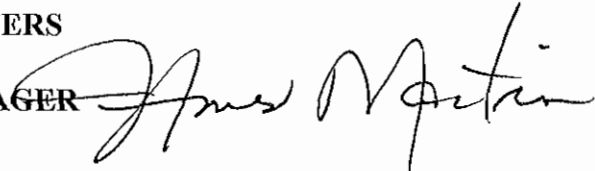
**FROM:** JAMES E. MARTIN, COUNTY MANAGER 

**DATE:** NOVEMBER 7, 2008

**SUBJECT:** LOCAL BRAC PROJECT COMMITTEE PRESENTATION  
BY JIM KONNEKER, CHAIRMAN

Mr. Jim Konneker, Chairman will be making a presentation of the Local BRAC Project Committee to the Board of Commissioners on Monday, November 17, 2008.

/ct  
CM110708-2



ITEM NO. 23

DEPARTMENT OF PUBLIC HEALTH  
227 Fountainhead Lane • Fayetteville, North Carolina 28301  
(910) 433-3600 • Fax: (910) 433-3659

**MEMORANDUM**

TO: Board of County Commissioners

THRU: Mrs. Juanita Pilgrim, Deputy County Manager *Juanita Pilgrim*

FROM: Mr. A. Wayne Raynor, Health Director *A. Wayne Raynor* **DWMC**

DATE: October 30, 2008

RE: Approval of Proposed Changes in the Vaccine Administration Fees

**BACKGROUND**

At the Board of Health meeting on October 21, 2008, the Board approved the attached change to the Vaccine Administration Fees due to a mandate from North Carolina Medicaid. Providers must now bill two separate CPT Codes when administering vaccine.

**RECOMMENDATION/PROPOSED ACTION**

Management requests to have this item placed on the next County Commissioners' meeting agenda for their approval to change the aforementioned Vaccine Administration Fees.

: Attachments  
/dwmc

*Celebrating Our Past... Embracing Our Future*



**DEPARTMENT OF PUBLIC HEALTH**  
 227 Fountainhead Lane • Fayetteville, North Carolina 28301  
 (910) 433-3600 • Fax: (910) 433-3659

---

## **REQUEST TO CHANGE THE VACCINE ADMINISTRATION FEE** **October 21, 2008**

### **BACKGROUND**

The Cumberland County Department of Public Health had been charging \$30.00 Administration Fee for vaccine administration regardless of how many vaccines a patient received.

Pursuant to the North Carolina Medicaid Special Bulletin II as it relates to Health Check Billing Requirements, Providers must use CPT Code 90471 or 90465 for one unit of administered vaccine. Providers must use CPT Code 90472 or 90466 for two or more units (each) of administered vaccine.

### **RECOMMENDATION**

The Medicaid reimbursable rate for 90471/90465 is \$17.25 and 90472/90466 is \$9.71. We are requesting that the vaccine administration fee be changed to \$18.00 and \$10.00 respectively.

<b>CPT CODE</b>	<b>CODE DESCRIPTION</b>	<b>CURRENT FEE</b>	<b>MEDICAID REIMB. FEE</b>	<b>PROPOSED FEE</b>
<b>90471/90465</b>	<b>ONE VACCINE</b>	<b>\$17.25</b>	<b>\$17.25</b>	<b>\$18.00</b>
<b>90472/90466</b>	<b>EACH TWO OR MORE VACCINES</b>	<b>\$9.71</b>	<b>\$9.71</b>	<b>\$10.00</b>

*Celebrating Our Past...Embracing Our Future*



ITEM NO. 2C

## COUNTY of CUMBERLAND



*Office of the County Manager*

James E. Martin  
County Manager

Cliff Spiller  
Assistant County Manager

Juanita Pilgrim  
Deputy County Manager

Amy H. Cannon  
Assistant County Manager

### MEMORANDUM FOR BOARD OF COMMISSIONERS AGENDA OF NOVEMBER 17, 2008

**TO:** BOARD OF COUNTY COMMISSIONERS

**FROM:** JAMES E. MARTIN, COUNTY MANAGER 

**DATE:** NOVEMBER 10, 2008

**SUBJECT:** APPROVAL OF REPORT ON FORMAL BID AWARDS OF \$100,000  
OR LESS APPROVED BY MANAGEMENT

#### BACKGROUND

The County Purchasing Policy delegates authority to the County Manager to award formal bids for purchases of \$100,000 or less. To assure an adequate public record is maintained, management periodically submits a report to the Board for inclusion in the official minutes listing the purchases approved by management pursuant to the County Purchasing Policy.

The following bids were awarded for the Cumberland County Solid Waste Department:

Wastequip	\$81,032
-----------	----------

/ct  
CM110708-1



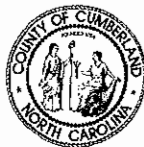

ITEM NO. \_\_\_\_\_

# COUNTY of CUMBERLAND

*Office of Solid Waste Management*

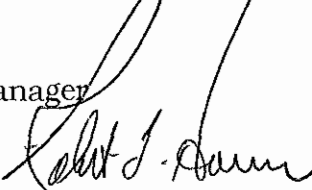
**DATE:** October 24, 2008  
**TO:** James Martin, County Manager  
**FROM:** Robert Howard, Director   
**THRU:** Thelma Matthews, Purchasing  
**SUBJECT:** Bid Approval for Compactor & Container Boxes

**BACKGROUND:**

Bids were received on October 8, 2008 for 20-yd roll off, 40 yd compactor, 30 yd roll-off, and 8 yd container boxes. Four bids were submitted.

<u>Company</u>	<u>20 yd</u>	<u>40 yd</u>	<u>30 yd</u>	<u>8 yd</u>
Cavalier Equipment	17942	32408	19246	18940.8
Lodal-South	19196	28996	21396	19664
Rudco South	19868	44744	21444	17344
Wastequip	17204	29812	18400	15616

**RECOMMENDATIONS:**

Recommend awarding the bid to Wastequip, the low bidder.

Sufficient funds are available for purchase of these trucks in the budget. See attached budget revisions.

The Recycling Division needs 12 8-yd container boxes with slots cut for cardboard; Wastequip will provide these boxes for the same price as the original bid, per conversation between Donald Tew, Collections Supervisor, and Brian Housinger, SAE Wastequip.

Attachment – Bid Tabulation

**BID AWARD FORM**

CUMBERLAND COUNTY  
SOLID WASTE  
FORMAL BID #09-15-SW-F  
COMPACTOR AND CONTAINER BOXES  
October 29, 2008

**PLEASE SEE ATTACHED BID TABULATION**

WE RECOMMEND THE BID BE AWARDED TO WASTEQUIP

JUSTIFICATION(IF DEPARTMENT DOES NOT RECOMMEND LOWEST BID.) \_\_\_\_\_

\_\_\_\_\_  
\_\_\_\_\_  
\_\_\_\_\_

DEPARTMENT HEAD SIGNATURE      See attached memo

\*\*\*\*\*

REVIEWED BY PURCHASING/CONTRACTS OFFICER

Thelma S. Matthews      DATE 10/29/08  
Thelma S. Matthews

APPROVAL/DISAPPROVAL BY COUNTY MANAGER

James E. Martin      DATE 10-29-08  
James E. Martin

CUMBERLAND COUNTY  
 SOLID WASTE  
 FORMAL BID #09-15-SW-F  
 COMPACTOR AND CONTAINER BOXES  
 OCTOBER 8, 2008 @ 3:00 P.M.

**BID TABULATION**

	4 ea 20 yd roll off <u>Container Boxes</u>	4 ea 40 yd <u>Compactor Boxes</u>	4 ea 30 yd roll off <u>Container Boxes</u>	16 ea 8 yd <u>Container Boxes</u>	<u>Total</u>
Bes-Pac	_____	_____	_____	_____	
Carolina Envi	_____	_____	_____	_____	
Cavalier Equip	\$17,942.00	\$32,408.00	\$19,246.00	\$18,940.80	\$88,536.80
Crane Carrier	_____	_____	_____	_____	
Kabco	_____	_____	_____	_____	
Lodal-South	\$19,196.00	\$28,996.00	\$21,396.00	\$19664.00 (12ga.) \$21584.00 (10ga.)	\$89,252.00
Marathon Equip	_____	_____	_____	_____	
Nu-Life Envi	_____	_____	_____	_____	
RJM Waste	_____	_____	_____	_____	
Rudco South	\$19,868.00	\$44,744.00	\$21,444.00	\$17,344.00	\$103,400.00
Triad Mack	_____	_____	_____	_____	
Waste Mangt	_____	_____	_____	_____	
Wastequip	\$17,204.00	\$29,812.00	\$18,400.00	\$15,616.00	\$81,032



ITEM NO. 20

OFFICE OF THE COUNTY ATTORNEY

Courthouse, 117 Dick Street – Suite 551 • P.O. Box 1829 • Fayetteville, North Carolina 28302-1829  
(910) 678-7762 • Fax: (910) 678-7758

November 12, 2008

**MEMORANDUM FOR BOARD OF COMMISSIONERS' AGENDA OF NOVEMBER 17, 2008:**

**TO: BOARD OF COMMISSIONERS**

**FROM: GRAINGER R. BARRETT, COUNTY ATTORNEY**

**SUBJECT: APPROVAL OF ASSIGNMENT BY ACQUISITION OF CENTERPLATE FOOD SERVICES CONCESSION CONTRACT AT THE CUMBERLAND COUNTY CROWN COLISEUM TO AFFILIATE OF KOHLBERG & COMPANY, LLC.**

**Background:** Service America Corporation d/b/a Centerplate currently has the concession franchise at the Crown Center under a contract dated July 14, 2007. Centerplate is being merged into and will become a wholly-owned subsidiary of an affiliate of Kohlberg & Company LLC. Centerplate has requested that the County consent to this transaction. Rina Teran, Vice President and General Counsel of Centerplate has confirmed that after the merger and its acquisition by Kohlberg that Centerplate will continue to be subject to and honor all its contractual obligations under its concessionaire contract for the Crown Center. She also advised that Centerplate management will remain in place after the transaction.

This is a description of Kohlberg from its website:

Kohlberg & Company, L.L.C. is a leading U.S. private equity firm which acquires "middle market" companies (valued from \$100 to \$500 million). Since its inception in 1987, the firm has organized six private equity funds, through which it has raised \$3.7 billion of committed capital. The firm's objective has been to realize substantial capital gains through control investments in a diversified portfolio of companies. The firm has completed approximately 100 platform and add-on acquisitions with an aggregate value of more than \$6 billion. Kohlberg & Company invests in companies where it can work in partnership with senior management to identify growth opportunities and implement fundamental operating and strategic changes, resulting in substantial increases in revenue and cash flow. The firm's use of moderate amounts of debt financing in acquiring companies affords them the financial flexibility necessary to attain these corporate objectives.

**Recommendation:** Approve and consent to assignment by acquisition of Centerplate Food Services Concession Contract at the Crown Center by affiliate of Kohlberg & Company and authorize Chairman to sign consent on behalf of County.

*Celebrating Our Past...Embracing Our Future*

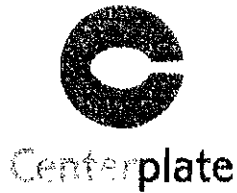

October 20, 2008

The Crown Center  
1960 Coliseum Drive  
Fayetteville, North Carolina 28306  
Attention: Paul Beard, Chief Executive Officer

**Re: Kohlberg Acquisition of Centerplate**

Dear Paul:

Recently, I wrote to you about a very positive event for Centerplate – the acquisition of the Company by an affiliate of Kohlberg & Company, LLC (“Kohlberg”), a leading U.S. private equity firm.

Centerplate is energized to be partnering with such a strong organization as Kohlberg. They understand our business, share our vision and are committed to working with us to build long-term solutions that deliver the most value for our clients and their customers. With the help of Kohlberg, Centerplate will be a more dynamic, better capitalized company, with an increased ability to provide cutting-edge service.

We anticipate completing this transaction over the next several months. In connection with the transaction, all outstanding Centerplate shares will be acquired by Kohlberg, and after the transaction, Centerplate will be owned by Kohlberg. During this interim period and after the transaction is completed, customers can expect the same high level of service that they have come to expect from Centerplate.

We have enclosed a form of consent we ask you to have signed and returned to us in connection with our preparation for the closing of the transaction. We would very much appreciate your returning the consent no later than November 10, 2008. If you have questions about the transaction, please do not hesitate to contact Bill Peterson via telephone at (213) 631-1555.

Sincerely,

Janet L. Steinmayer  
President and Chief Executive Officer

The Crown Center  
October 20, 2008  
Page 2

cc: County Manager  
P.O. Drawer 1829  
Fayetteville, North Carolina 28302



Centerplate

October 20, 2008

The Crown Center  
1960 Coliseum Drive  
Fayetteville, North Carolina 28306  
Attention: Paul Beard, Chief Executive Officer

**Re: Consent**

Dear Paul:

Reference is hereby made to the Food and Beverage Services Agreement dated July 14, 2007 between Service America Corporation d/b/a Centerplate (the "Company") and The Cumberland County Board of Commissioners (the "Agreement").

As previously announced, Centerplate, Inc., the Company's parent, has entered into an Agreement and Plan of Merger with KPLT Holdings, Inc. and KPLT Mergerco, Inc. whereby KPLT Mergerco, Inc. will be merged with and into Centerplate, Inc. (the "Merger") and Centerplate, Inc. will survive the Merger as a wholly-owned subsidiary of an affiliate of Kohlberg & Company, L.L.C. (the "Transaction").

The Agreement includes certain provisions relating to transfers of ownership of the Company and/or Centerplate, Inc. Although the Merger may not technically qualify as a matter requiring your consent under the Agreement, we request that you sign this letter to confirm that your consent is not required or, if you believe your consent is required, to consent to the Transaction. By signing this letter, you are acknowledging that the consummation of the Merger will not constitute a default or breach of the Agreement, and that the Agreement will remain in effect, unmodified, immediately following the consummation of the Transaction.

Please have this letter executed on behalf of The Cumberland County Board of Commissioners where indicated below and return it to Centerplate, Inc. at your earliest convenience via email to Jill Crowe at [jill.crowe@centerplate.com](mailto:jill.crowe@centerplate.com) or via facsimile, Attention: Jill Crowe, at (203) 975-5949. It would be greatly appreciated if you would return your signed consent no later than November 10, 2008. If you have any questions whatsoever, please do not hesitate to contact Bill Peterson via telephone at (213) 631-1555.

The Crown Center  
October 20, 2008  
Page 2

We are looking forward to the benefits the Transaction will bring to us and our ability to serve our clients and their customers. We value our relationship with you, and we appreciate your support.

Sincerely,



Janet L. Steinmayer  
President and Chief Executive Officer

Acknowledged and agreed this \_\_\_ day of \_\_\_\_\_, 2008.

The Cumberland County Board of Commissioners

By: \_\_\_\_\_

Name: \_\_\_\_\_

Title: \_\_\_\_\_

Duly Authorized

cc: County Manager  
P.O. Drawer 1829  
Fayetteville, North Carolina 28302



**COUNTY OF CUMBERLAND  
BUDGET REVISION REQUEST**

Budget Office Use	
Budget Revision No.	<u>B09-205</u>
Date Received	<u>11-5-08</u>
Date Completed	

Fund No. 101 Agency No. 431 Organ. No. 432G

Organization Name: BREAST and CERVICAL CANCER CONTROL PROGRAM ITEM NO. 2E(1)

**REVENUE**

Revenue Source Code	Description	Current Budget	Increase (Decrease)	Revised Budget
4171	N.C. BREAST and CERVICAL CANCER CONTROL	51,967	34,637	86,604
		51,967	34,637	86,604

**EXPENDITURES**

Object Code	Appr Unit	Description	Current Budget	Increase (Decrease)	Revised Budget
2379	205	INCENTIVES	700	737	1,437
2601	205	OFFICE SUPPLIES	500	250	750
2992	205	DEPARTMENT SUPPLIES	1,000	750	1,750
3203	205	LABORATORY / X-RAY	480	1,000	1,480
3390	205	CONTRACTED SERVICES	49,000	31,000	80,000
3470	205	TRAVEL	400	600	1,000
3474	205	TRAINING	200	300	500
Total			52,280	34,637	86,917

**Justification:**

THIS BUDGET REVISION REQUESTS TO BUDGET FOR ADDITIONAL STATE FUNDING THAT THE DEPARTMENT HAS BEEN NOTIFIED THAT IT CAN EXPECT TO RECEIVE .

Fund Balance: State: 34,637 Federal: \_\_\_\_\_ County: \_\_\_\_\_ New: \_\_\_\_\_ Other: \_\_\_\_\_  
Other: \_\_\_\_\_ Fees: \_\_\_\_\_ Prior Year: \_\_\_\_\_

Submitted By: <u>[Signature]</u> Department Head	<u>11/3/08</u> Date:	Approved By:  County Manager  Board of County Commissioners Date: _____
Reviewed By: <u>[Signature]</u> Finance Department	<u>11-5-08</u> Date:	
Reviewed By: <u>[Signature]</u> Deputy Assistant County Mgr	<u>11/10/08</u> Date:	

**COUNTY OF CUMBERLAND  
BUDGET REVISION REQUEST**

Budget Office Use	
Budget Revision No.	<u>B09.206</u>
Date Received	<u>11/5/2008</u>
Date Completed	

Fund No. 101 Agency No. 426 Organ. No. 4217  
 Organization Name: Pre-Trial Release

ITEM NO. 2E(2)

**REVENUE**

Revenue Source Code	Description	Current Budget	Increase (Decrease)	Revised Budget
3316	City of Fayetteville	0	10,000	10,000
		0	10,000	10,000

**EXPENDITURES**

Object Code	Appr Unit	Description	Current Budget	Increase (Decrease)	Revised Budget
3462	140	Rent Equipment	51,779	10,000	61,779
Total			51,779	10,000	61,779

**Justification:**

Revision in the amount of \$10,000 to recognize funding from City of Fayetteville for GPS program.

**Funding Source:**

State: \_\_\_\_\_ Federal: \_\_\_\_\_ County: \_\_\_\_\_ New: \_\_\_\_\_ Other: \_\_\_\_\_  
 Other: \_\_\_\_\_ Fees: \_\_\_\_\_ Prior Year: \_\_\_\_\_

**Fund Balance:**

Submitted By: Carrie Gardner Date: 11-5-08  
 Department Head  
 Reviewed By: Kelly Austry Date: 11-5-08  
 Finance  
 Reviewed By: Amy Cannon Date: 11/10/08  
 Deputy/Assistant County Mgr

Approved By:	
_____	Date: _____
County Manager	
_____	Date: _____
Board of County Commissioners	
_____	Date: _____

**COUNTY OF CUMBERLAND  
BUDGET REVISION REQUEST**

Budget Office Use	
Budget Revision No.	B09-212
Date Received	11/6/2008
Date Completed	

Fund No. 107 Agency No. 450 Organ. No. 4577  
 Organization Name: Emergency Addressing

ITEM NO. 2E(3)

**REVENUE**

Revenue Source Code	Description	Current Budget	Increase (Decrease)	Revised Budget
7670	Miscellaneous Revenue	10,000	2,500	12,500
Total		10,000	2,500	12,500

**EXPENDITURES**

Object Code	Appr Unit	Description	Current Budget	Increase (Decrease)	Revised Budget
2995	412	Computer Software	88,050	2,500	90,550
Total			88,050	2,500	90,550

**Justification:**

Revision in the amount of \$2,500 to recognize funding from Board of Education for a share of web mapping software contract.

**Funding Source:**

State: \_\_\_\_\_ Federal: \_\_\_\_\_ County: \_\_\_\_\_ New: \_\_\_\_\_ Other: \_\_\_\_\_  
 Other: \_\_\_\_\_ Fees: \_\_\_\_\_ Prior Year: \_\_\_\_\_

**Fund Balance:**

Submitted By: \_\_\_\_\_ Date: \_\_\_\_\_  
 Department Head  
 Reviewed By: *Kelly Autry* Date: 11-6-08  
 Finance  
 Reviewed By: *Amber Cannon* Date: 11/10/08  
 Deputy Assistant County Mgr

<b>Approved By:</b>	
_____	Date: _____
County Manager	
_____	Date: _____
Board of County Commissioners	
_____	Date: _____

**COUNTY OF CUMBERLAND  
BUDGET REVISION REQUEST**

Budget Office Use	
Budget Revision No.	B09-201
Date Received	11/4/2008
Date Completed	

Fund No. 101 Agency No. 410 Organ. No. 4120  
 Organization Name: Information Services

ITEM NO. 2E(4)

**REVENUE**

pg 1 of 2

Revenue Source Code	Description	Current Budget	Increase (Decrease)	Revised Budget
9145	Transfer from Fund 104	0	63,095	63,095
		0	63,095	63,095

**EXPENDITURES**

Object Code	Appr Unit	Description	Current Budget	Increase (Decrease)	Revised Budget
1210	009	Salaries Regular	976,102	50,808	1,026,910
1810	009	FICA	74,980	3,887	78,867
1820	009	Retirement Contribution	48,576	2,490	51,066
1824	009	Retirement Contribution 401K	9,913	508	10,421
1830	009	Medical Insurance	79,500	5,300	84,800
1860	009	Workers Compensation	1,952	102	2,054
Total			1,191,023	63,095	1,254,118

**Justification:**

Revision in the amount of \$63,095 request new Server Systems Administrator position to support the expanded requirements of the Emergency 911 system and will be paid by E911 funds.

**Funding Source:**

State: \_\_\_\_\_  
 Other: \_\_\_\_\_

**Fund Balance:**

Federal: \_\_\_\_\_ County: \_\_\_\_\_ New: \_\_\_\_\_  
 Fees: \_\_\_\_\_ Prior Year: \_\_\_\_\_

Other: \_\_\_\_\_

Submitted By: Betty M. Coard Date: 11-5-08  
 Department Head  
 Reviewed By: Kelly Cutrup Date: 11-6-08  
 Finance  
 Reviewed By: Amy Cannon Date: 11/10/08  
 Deputy Assistant County Mgr

<b>Approved By:</b>	
_____	Date: _____
County Manager	
_____	Date: _____
Board of County Commissioners	
_____	Date: _____

**COUNTY OF CUMBERLAND  
BUDGET REVISION REQUEST**

Budget Office Use	
Budget Revision No.	B09-201A
Date Received	11/4/2008
Date Completed	

Fund No. 104 Agency No. 450 Organ. No. 4595  
 Organization Name: Emergency Telephone System

*Pg 2 of 2*

**REVENUE**

Revenue Source Code	Description	Current Budget	Increase (Decrease)	Revised Budget
4633	Telephone Surcharge 911	791,336	63,095	854,431
		791,336	63,095	854,431

**EXPENDITURES**

Object Code	Appr Unit	Description	Current Budget	Increase (Decrease)	Revised Budget
3880	401	Transfer to Fund 101	0	63,095	63,095
		Total	0	63,095	63,095

**Justification:**

Revision in the amount of \$63,095 fund a new Server Systems Administrator position in the Information Services department to support the expanded requirements of the Emergency 911 system and will be paid by E911 funds.

**Funding Source:**

State: \_\_\_\_\_ Federal: \_\_\_\_\_ County: \_\_\_\_\_ New: \_\_\_\_\_ Other: \_\_\_\_\_  
 Other: \_\_\_\_\_ Fees: \_\_\_\_\_ Prior Year: \_\_\_\_\_

**Fund Balance:**

Submitted By: <u><i>Kenneth Cain</i></u> Department Head	Date: <u>11/5/08</u>	Approved By:  _____ Date: _____ County Manager  Board of County Commissioners Date: _____
Reviewed By: <u><i>Kelly Outrey</i></u> Finance	Date: <u>11-6-08</u>	
Reviewed By: <u><i>Amy Cannon</i></u> <del>Deputy</del> Assistant County Mgr	Date: <u>11/10/08</u>	

**COUNTY OF CUMBERLAND  
BUDGET REVISION REQUEST**

Budget Office Use	
Budget Revision No.	<u>309-213</u>
Date Received	<u>11-7-08</u>
Date Completed	

Fund No. 107 Agency No. 450 Organ. No. 4575  
 Organization Name: Emergency 911

ITEM NO. 2 E(5)

**REVENUE**

Revenue Source Code	Description	Current Budget	Increase (Decrease)	Revised Budget
9901	Fund Balance Appropriated	199,900	24,050	223,950
Total		199,900	24,050	223,950

**EXPENDITURES**

Object Code	Appr Unit	Description	Current Budget	Increase (Decrease)	Revised Budget
2995	412	Computer Software	76,000	12,050	88,050
299A	412	Computer Hardware	0	12,000	12,000
Total			76,000	24,050	100,050

**Justification:**

Revision in the amount of \$24,050 to appropriate fund balance for additional digital logging recorder system.

**Funding Source:**

State: \_\_\_\_\_  
 Other: \_\_\_\_\_

**Fund Balance:**

Federal: \_\_\_\_\_ County: \_\_\_\_\_ New: \_\_\_\_\_  
 Fees: \_\_\_\_\_ Prior Year: 24,050

Other: \_\_\_\_\_

Submitted By: [Signature] Date: 11/6/08  
 Department Head

Reviewed By: [Signature] Date: 11-7-08  
 Finance

Reviewed By: [Signature] Date: 11/10/08  
 Deputy Assistant County Mgr

<b>Approved By:</b>	
	Date: _____
County Manager	
	Date: _____
Board of County Commissioners	
	Date: _____

**COUNTY OF CUMBERLAND  
BUDGET REVISION REQUEST**

Budget Office Use	
Budget Revision No.	<u>809-218</u>
Date Received	<u>11/10/08</u>
Date Completed	

Fund No. 101 Agency No. 437 Organ. No. 4365  
 Organization Name: SOCIAL SERVICES

ITEM NO. 2 E(6)

**REVENUE**

Revenue Source Code	Description	Current Budget	Increase (Decrease)	Revised Budget
4355	NC CRISIS INTERVENTION	424,917	483,767	908,684
Total		424,917	483,767	908,684

**EXPENDITURES**

Object Code	Appr Unit	Description	Current Budget	Increase (Decrease)	Revised Budget
4389	262	CRISIS INTERVENTION	424,917	483,767	908,684
Total			424,917	483,767	908,684

To recognize additional funding.

**Funding Source:** State: \_\_\_\_\_ Federal: 483,767 County: \_\_\_\_\_ New: \_\_\_\_\_ Other: \_\_\_\_\_  
 Other: \_\_\_\_\_ Fees: \_\_\_\_\_ Prior Year: \_\_\_\_\_

Submitted By: [Signature] Date: 11-6-08  
 Department Head  
 Reviewed By: [Signature] Date: 11/10/08  
 Budget Analyst  
 Reviewed By: [Signature] Date: 11/10/08  
 Deputy Assistant County Mgr  
 Reviewed By: \_\_\_\_\_ Date: \_\_\_\_\_  
 Information Services

Approved By:	
_____	Date: _____
County Manager	
_____	Date: _____
Board of County Commissioners	
_____	Date: _____

ROBERT N. STANGER, P.E.  
County Engineer



SAM LUCAS  
Engineering Technician II

WAYNE DUDLEY, CFM  
Engineering Technician I

ENGINEERING DEPARTMENT

Historic Courthouse, 130 Gillespie Street • P.O. Box 1829 • Fayetteville, North Carolina 28302-1829  
Telephone (910) 678-7636 • Fax (910) 678-7635

November 12, 2008

ITEM NO. 2F

**MEMORANDUM**

**TO: BOARD OF COUNTY COMMISSIONERS**

**FROM: ROBERT N. STANGER, COUNTY ENGINEER** *RNS*

**THROUGH: CLIFF SPILLER, ASSISTANT COUNTY MANAGER**

**SUBJECT: CHANGE ORDER G-2 FOR M&E CONTRACTING  
LIFE SAFETY IMPROVEMENTS ANN STREET LANDFILL BALING FACILITY**

BACKGROUND

On August 4, 2008, the Board of Commissioners awarded a contract to M&E Contracting in the amount of \$240,699.00 for the Life Safety Improvements Project at the Ann Street Landfill Baling Facility. The scope of work included repair to the automatic sprinkler system, fire alarm system, electrical system and other improvements in the baling facility required by the City Fire Marshall's Office for continued use of the building by the Solid Waste Department.

Attached is Change Order G-2 in the amount of \$42,274.13 for additional work on the above referenced project. The additional work is outlined in the Change Order document and includes items required by the City Fire Marshall's Office as well as replacement of defective plumbing, electrical and fire sprinkler system components that were not discovered until work began on the project. Change Order G-1 in the amount of \$16,778.27 was previously approved by the County Manager and was funded from the contingency established by the Board at the time of bid award. Sufficient monies are available in the Solid Waste Department budget to fund this Change Order.

RECOMMENDATION/PROPOSED ACTION

The recommendation of the County Engineer, Solid Waste Director, Detter & Associates, and management is to:

1. Approve Change Order G-2 for M&E Contracting in the amount of \$42,274.13 and increase the total contract amount to \$299,751.40 for the Life Safety Improvements Project at Ann Street Landfill Baling Facility.
2. Approve the attached budget revision.

The proposed action by the Board is to follow the staff recommendation.

*Celebrating Our Past...Embracing Our Future*



**CHANGE ORDER**

Distribution To:  
OWNER   
ENGINEER   
CONTRACTOR   
FIELD   
OTHER

**PROJECT:** Cumberland County  
Life Safety Improvements to  
Ann Street Landfill Baling Facility

**CHANGE ORDER NUMBER:** G-2

**INITIATION DATE:** November 10, 2008

**TO:** M & E Contracting, Inc.  
P.O. Box 25100  
Fayetteville, NC 28314-5100

**ENGINEER'S PROJECT NO:**

**CONTRACT FOR:** General Construction

**CONTRACT DATE:** August 4, 2008

You are directed to make the following changes in this Contract:

Additional labor, materials and equipment to add additional horn/strobes for fire alarm system; replace backflow preventer, valves and piping for plumbing system; add circuits for exit lights and repair three (3) high bay lights; repair roof leaks; add high/low air supervisory switches, high pressure alarm switches and replace two (2) dry pipe valves on the fire sprinkler system; and add coverage under the open stairs, catwalks and offices in the warehouse area of the building on the fire sprinkler system.

**ADD: \$42,274.13**

Through the acceptance of this Change Order, the Contractor acknowledges that he has reviewed the status of the work to date and that this Change Order represents the final and complete payment for the above stated additional work on the Life Safety Improvements to Ann Street Landfill Baling Facility Project and includes any and all costs for delays, claims or demands against the Owner. The Contractor by accepting the Change Order agrees to indemnify the Owner and all other parties associated with this project forever from liens or claims from the Contractor or any other person directly or indirectly acting for, through, or under the Contractor.

Not valid until signed by the Owner, the Architect and the Construction Manager.  
Signature of the Contractor indicates agreement herewith, including any adjustment in the Contract Sum or the Contract Time.

The original (Contract Sum) ( <del>Guaranteed Maximum Cost</del> ) was.....	\$	240,699.00
Net change by previously authorized Change Orders.....	\$	16,778.27
The (Contract Sum) ( <del>Guaranteed Maximum Cost</del> ) prior to this Change Order was.....	\$	257,477.27
The (Contract Sum) ( <del>Guaranteed Maximum Cost</del> ) will be (increased) (decreased) (unchanged) by this Change Order.....	\$	42,274.13
The new (Contract Sum) ( <del>Guaranteed Maximum Cost</del> ) including this Change Order will be.....	\$	299,751.40
The Contract Time will be (increased) by		(12) Days
The Date of Substantial Completion as of the date of this Change Order therefore is January 20, 2009.		

Detter & Associates  
ENGINEER

M & E Contracting, Inc.  
CONTRACTOR

County of Cumberland  
OWNER

P.O. Box 53827  
Fayetteville, NC 28305

P.O. Box 25100  
Fayetteville, NC 28314

P.O. Box 1829  
Fayetteville, NC 28302

By: \_\_\_\_\_

By: \_\_\_\_\_

By: \_\_\_\_\_

DATE: \_\_\_\_\_

DATE: \_\_\_\_\_

DATE: \_\_\_\_\_

**DETTOR & ASSOCIATES**

**Consulting Engineer**

Post Office Box 53827  
Fayetteville, N C 28305  
910/485-7778:voice  
910/485-5883:fax  
E-mail: jamesdetter@embarqmail.com

November 10, 2008

Mr. Robert N. Stanger, P. E.  
County Engineer  
Engineering Department  
Cumberland County  
P O Drawer 1829  
Fayetteville, N C 28302  
Fax: 678.7631

RE: Life Safety Improvements – Ann Street Landfill Baling Facility  
698 Ann Street  
Fayetteville N C

Dear Bob:

Attached are eight change order cost proposals for the following:

No. 5 Fire Alarm - additional horn/strobes	-	\$3,235.10
No. 6 Plumbing - replace backflow preventer, valves, & pipe	-	\$2,618.00
No. 7 Electrical - circuits for exit lights	-	\$3,266.34
No. 8 Electrical - repair 3 high bay lights	-	\$652.16
No. 9 Roof - repair leaks	-	\$3,555.20
No.10 Fire Sprinkler - add high/low air supervisory switches & high pressure alarm switches	-	\$1,943.14
No. 11 Fire Sprinkler - replace two dry pipe valves	-	\$10,441.08
No 12 Fire Sprinkler - add coverage under the open stairs, catwalks, and offices in 1 <sup>st</sup> area warehouse only	-	<u>\$16,563.11</u>
<b>TOTAL</b>		<b>\$42,274.13</b>

Nos. 6 & 9 are stipulated for a specific quantity of work and there may be some additional costs depending on what they find as they progress with the work.

If you have any questions, please give me a call.

Sincerely yours,

**DETTOR & ASSOCIATES**

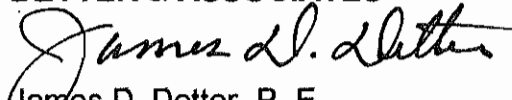
  
James D. Detter, P. E.  
Enclosures as



Dónovan McLaurin,  
Chair  
Wade, Falcon & Godwin

Lori Epler,  
Vice-Chair  
Cumberland County

Garland C. Hostetter,  
Town of Spring Lake  
Harvey Cain, Jr.,  
Town of Stedman  
Patricia Hall,  
Town of Hope Mills  
Charles C. Morris  
Town of Linden

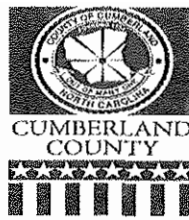

## COUNTY of CUMBERLAND

### Planning and Inspections Department

Thomas J. Lloyd,  
Director

Cecil P. Combs,  
Deputy Director

Walter Clark,  
Roy Turner,  
Sara E. Pifland,  
Cumberland County

Benny Pearce  
Town of Eastover

NOVEMBER 7, 2008

ITEM NO. 3A

MEMO TO: Cumberland County Board of Commissioners

FROM: Cumberland County Joint Planning Board

SUBJECT: **Case P08-52:** Rezoning of 1.64+/- acres from A1 Agricultural to R15 Residential or to a more restrictive zoning district, located at 2463 Cedar Creek Road, submitted by Brady L. Rufenacht, owned by Watermark Homes Inc.

ACTION: Members present at the October 21, 2008 meeting voted unanimously to recommend approval of R20 Residential district.

**SITE INFORMATION: Frontage & Location:** 295.00'+/- on Cedar Creek Road; **Depth:** 516.00'+/- **Jurisdiction:** Cumberland County; **Adjacent Property:** Yes, 2 tracts east of subject property; **Current Use:** 2 vacant lots; **Initial Zoning:** A1 – September 14, 1979 (Area 9); **Nonconformities:** None; **Zoning Violation(s):** None; **Surrounding Zoning:** North: A1, PND, CP & MP; East: A1, RR & R15; South: A1 & A1/CU (to allow automotive car sales); West: A1, HS(P) & C(P); **Surrounding Land Use:** Commercial (including motor vehicle sales, convenience retail w/gasoline sales, variety, gift and hobby supply and retail sales) and residential (including 1-abandoned dwelling); **2010 Land Use Plan:** Low density residential; **Special Flood Hazard Area (SFHA):** None; **Water/Sewer Availability:** PWC/PWC; water is available and sewer exists 650 ft. west of site; **Soil Limitations:** Yes, hydric – Ra Rains sandy loam and Le Leon sand; **School Capacity/Enrolled:** JW Seabrook Elementary: 310/328; Mac Williams Middle: 1,270/1,200; Cape Fear High: 1,425/1,490; **Subdivision/Site Plan:** Approved preliminary zero lot line subdivision (Case No. 08-134); **Sewer Service Area:** Yes; **Average Daily Traffic Count (2006):** 9,300 on Cedar Creek Road; 1,600 on AB Carter Road; **Highway Plan:** Cedar Creek Road is identified in the Highway Plan as a major thoroughfare. This proposal calls for a multi-lane facility (U-4415) with a right-of-way of 100 feet. Road improvements are included in the 2009-2015 MTIP; **Note: Density:** R40 – 1 lot/ 2 units, R30 – 2 lots/ units RR/R20/R20A – 3 lots/ 4 units, R15 – 4 lots/ 5 units; **Density (minus 15% for r/w):** R40 – 1 lot/ 2 units, R30 – 2 lots/ units, RR/R20/R20A – 3 lots/ units, R15 – 4 lots/ units.

#### MINUTES OF OCTOBER 21, 2008

The Planning & Inspections Staff recommends denial of the request for R15 Residential and recommends approval of R20 Residential zoning district based on the following:

1. The recommendation is consistent with the 2010 Land Use Plan, which calls for low density residential at this location;
2. Public utilities are available to the subject property and extension will be required upon development.

Case P08-52 Continued

The R40 and R30 Residential districts could also be found suitable in this area.

The applicant verbally agreed with the recommendation to R20 Residential.

**A motion was made by Mrs. Piland, seconded by Mr. Hostetter, to follow the staff recommendation and approve case P08-50. Unanimous approval.**

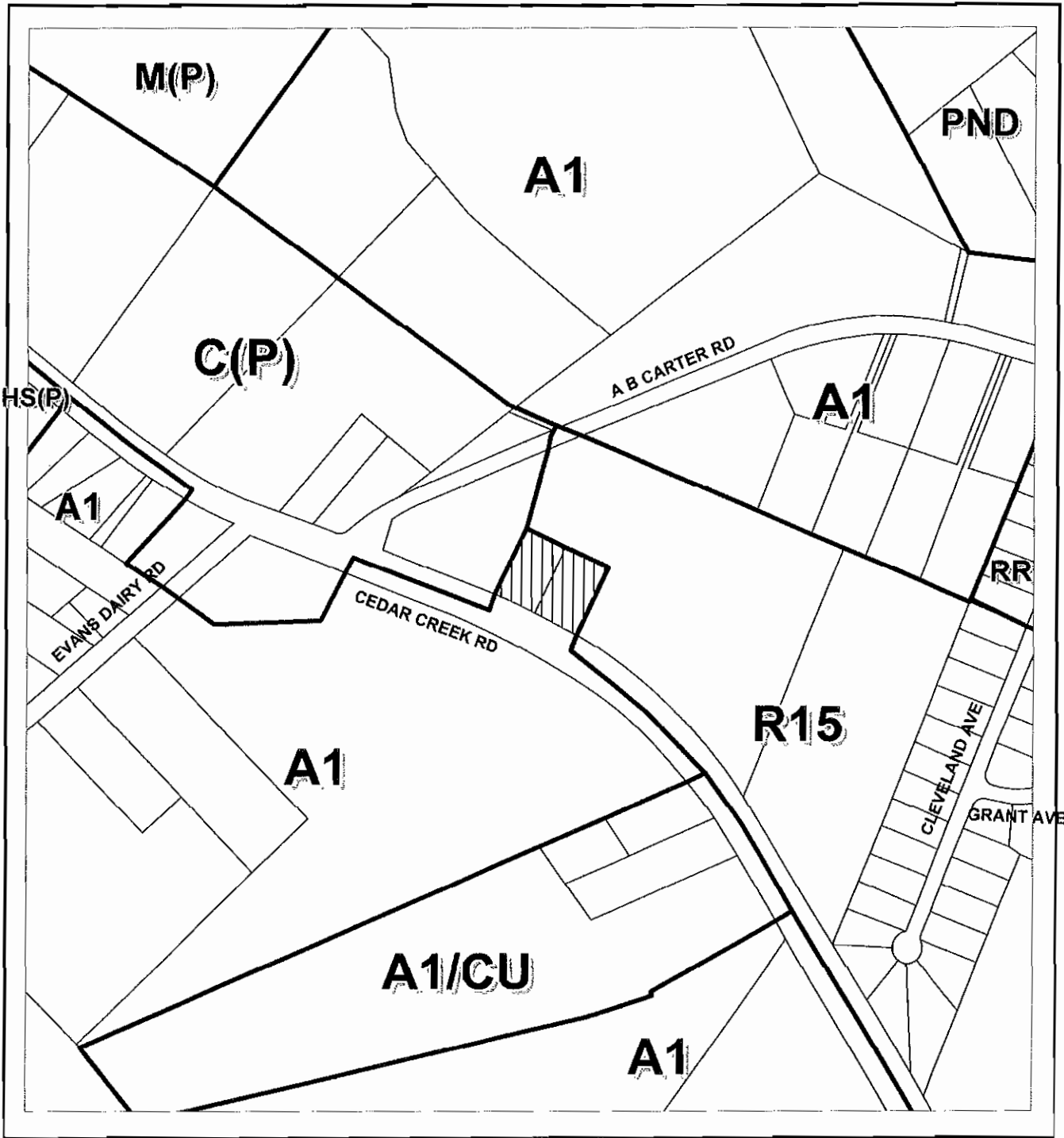

N

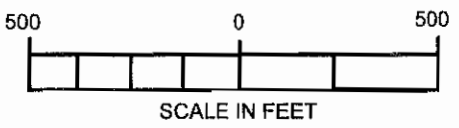

**REQUESTED REZONING:  
A1 TO R15**

<b>ACREAGE: 1.64 AC. +/-</b>		<b>HEARING NO: P08-52</b>	
<b>ORDINANCE: COUNTY</b>	<b>HEARING DATE</b>	<b>ACTION</b>	
<b>STAFF RECOMMENDATION</b>			
<b>PLANNING BOARD</b>			
<b>GOVERNING BOARD</b>			

Dorovan McLaurin,  
Chair  
Wade, Falcon & Godwin

Lori Epler,  
Vice-Chair  
Cumberland County

Garland C. Hostetter,  
Town of Spring Lake  
Harvey Cain, Jr.,  
Town of Stedman  
Patricia Hall,  
Town of Hope Mills  
Charles C. Morris,  
Town of Linden

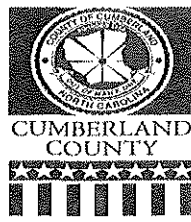

**COUNTY of CUMBERLAND**  
*Planning and Inspections Department*

Thomas J. Lloyd,  
Director

Cecil P. Combs,  
Deputy Director

Walter Clark,  
Roy Turner,  
Sara E. Piland,  
Cumberland County

Benny Pearce,  
Town of Eastover

NOVEMBER 7, 2008

ITEM NO. 3B

MEMO TO: Cumberland County Board of Commissioners

FROM: Cumberland County Joint Planning Board

SUBJECT: **Case P08-53:** Rezoning of .55+/- acres from M(P) Planned Industrial/Conditional Use District ( to allow storage of explosive materials) and the Permit to A1 Agricultural or to a more restrictive zoning district, located at 315 Magnolia Church Road, submitted and owned by Larry W. Hall.

ACTION: Members present at the October 21, 2008 meeting voted unanimously to recommend approval of A1 Agricultural district.

**SITE INFORMATION:** **Frontage & Location:** Off of Magnolia Church Road; **Depth:** 160.00'+/-; **Jurisdiction:** Cumberland County; **Adjacent Property:** Yes, parent tract; **Current Use:** Vacant lot; **Initial Zoning:** A1 – September 3, 1976 (Area 20); Rezoned to M(P)/CUD on May 15, 2006; **Nonconformities:** None; **Zoning Violation(s):** None; **Surrounding Zoning:** North: A1 & C3; East: A1 & R10 (County/Stedman); South: A1 & RR (County/Stedman), R10 & C1; West: RR & C3; **Surrounding Land Use:** Residential (including manufactured homes), religious worship facility, farmland and woodland; **Stedman Land Use Plan:** Suburban residential; **Special Flood Hazard Area (SFHA):** None; **Water/Sewer Availability:** Well/Septic; **Soil Limitations:** None; **School Capacity/Enrolled:** Stedman Primary: 200/182; Stedman Elementary: 300/308; Mac Williams Middle: 1,270/1,200; Cape Fear High: 1,425/1,490; **Subdivision/Site Plan:** Lot has been approved as zero lot line subdivision (Case No. 08-149); **Municipal Influence Area:** Town of Stedman; **Average Daily Traffic Count (2006):** 13,000 on Clinton Road (HWY 24); 590 on Magnolia Church Road; **Highway Plan:** There are no road improvements/constructions specified for this area. This case has no impact on the current Highway Plan or Transportation Improvement Program; **Note:** The approved M(P)/CUD & Permit (to allow storage of explosive materials) has ceased operations.

MINUTES OF OCTOBER 21, 2008

The Planning and Inspections Staff recommends approval of the request for A1 Agricultural based on the following:

1. Although the A1 Agricultural district is not consistent with the Stedman Area Land Use Plan, it is consistent with the lot sizes and land uses within the general area; and
2. The subject lot is a portion of the original tract and rezoning to A1 Agricultural district would allow for the property to be under the same ownership to have the same zoning classification.

There are no other suitable zoning districts to be considered for this location at this time.

Case P08-53 Continued

**A motion was made by Mrs. Piland, seconded by Mr. Hostetter, to follow the staff recommendation and approve case P08-50. Unanimous approval.**



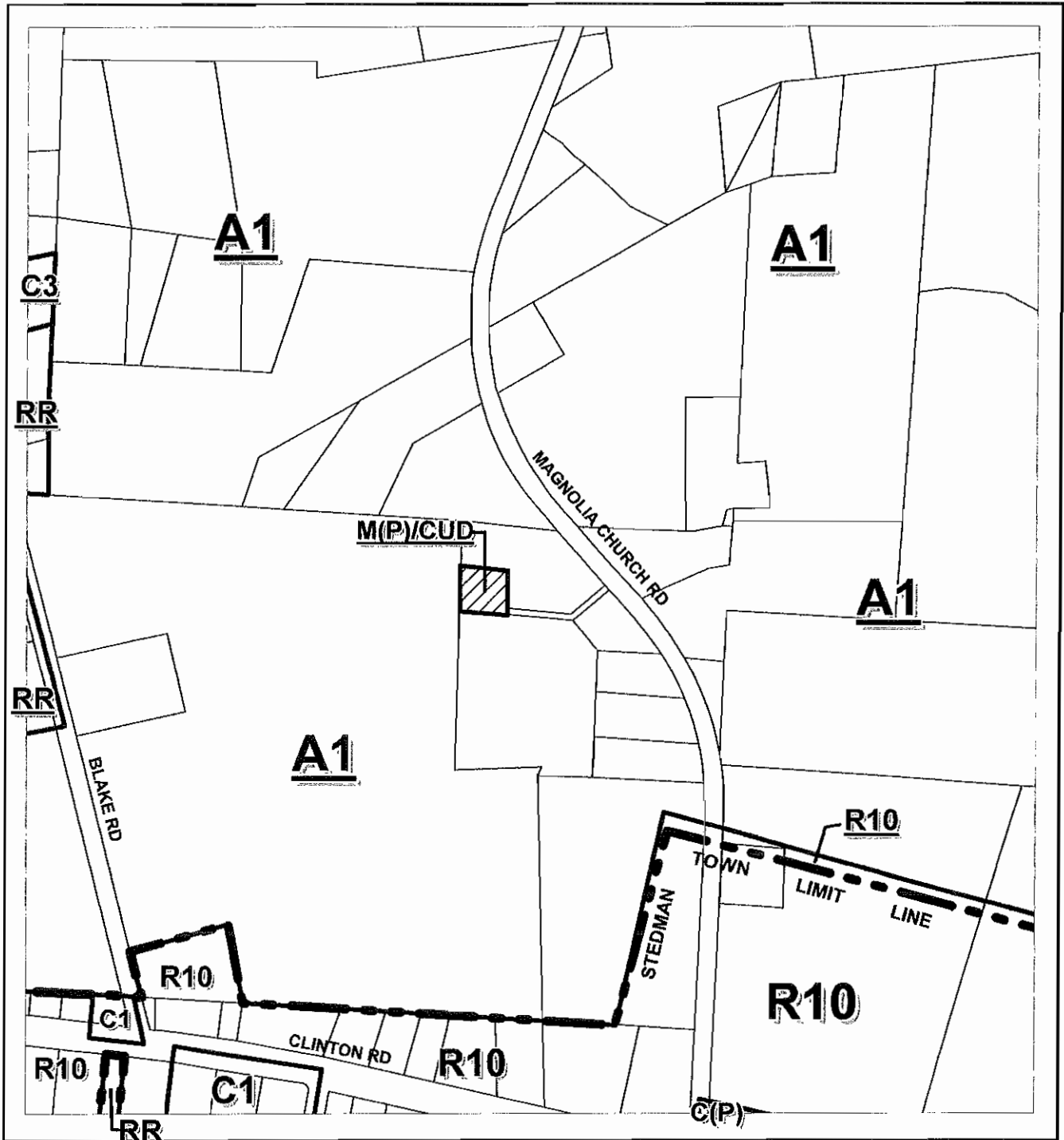

## REQUESTED REZONING: M(P)/CUD TO A1

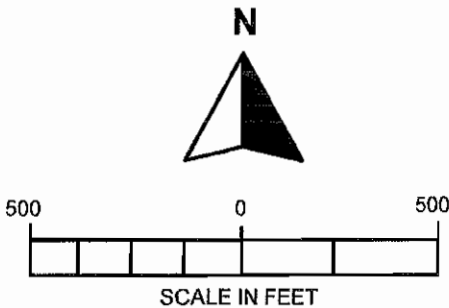

<b>ACREAGE: 0.55 AC.+/-</b>		<b>HEARING NO: P08-53</b>	
ORDINANCE: COUNTY	HEARING DATE	ACTION	
STAFF RECOMMENDATION			
PLANNING BOARD			
GOVERNING BOARD			

Denovan McLaurin,  
Chair  
Wade, Falcon & Godwin

Lori Epler,  
Vice-Chair  
Cumberland County

Garland C. Hostetter,  
Town of Spring Lake  
Harvey Cain, Jr.,  
Town of Stedman  
Patricia Hall,  
Town of Hope Mills  
Charles C. Morris,  
Town of Linden

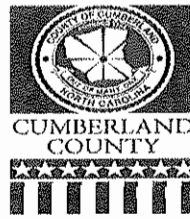

## COUNTY of CUMBERLAND

Planning and Inspections Department

Thomas J. Lloyd,  
Director

Cecil P. Combs,  
Deputy Director

Walter Clark,  
Roy Turner,  
Sara E. Piland,  
Cumberland County

Benny Pearce,  
Town of Eastover

NOVEMBER 7, 2008

ITEM NO. 30

MEMO TO: Cumberland County Board of Commissioners

FROM: Cumberland County Joint Planning Board

SUBJECT: **Case P08-54:** Rezoning of .52+/- acres from MXD Mixed Use Development/CUD Conditional Use District & Permit to R7.5 Residential and R10 Residential to MXD Mixed Use Development/CUD Conditional Use District & Permit or to a more restrictive zoning district, located on the south side of Elk Road, west of Pinewood Drive, submitted by Reverend Tracy Pounders, owned by Fayetteville Christian Schools, Inc.

ACTION: Members present at the October 21, 2008 meeting voted *unanimously* to recommend approval of.

SITE INFORMATION: **Frontage & Location:** No frontage; **Depth:** 1,300.00'+/-; **Jurisdiction:** Cumberland County; **Adjacent Property:** Yes, parent tract; **Current Use:** Vacant; **Initial Zoning:** R10 – November 17, 1975 (Area 4); Rezoned to MXD/CUD on November 21, 2005; **Nonconformities:** None; **Zoning Violation(s):** None; **Surrounding Zoning:** North: RR, R20, R10, R6A, O&I(P) & C(P); South: R15 & R10 (Hope Mills/County); West: R10; **Surrounding Land Use:** Residential, utility substation and woodlands; **2010 Land Use Plan:** Low density residential; **Special Flood Hazard Area (SFHA):** None; **Water/Sewer Availability:** PWC/PWC; water and sewer exist on Sycamore Drive; **Soil Limitations:** Yes, hydric on the northwest and south sides of subject property – JT Johnston loam; **School Capacity/Enrolled:** Ed V. Baldwin Elementary: 790/696; South View Middle: 900/884; South View High: 1,800/1,872; **Municipal Influence Area:** Town of Hope Mills; **Average Daily Traffic Count (2006):** 14,000 on Legion Road; 9,600 on Elk Road; **Highway Plan:** There are no road improvements/constructions specified for this area. This case has no impact on the current Highway Plan or Transportation Improvement Program; **Note:** Case No. P06-01-C, Special Use Permit for a cell tower approved 1/19/06; relocation of proposed cell tower will require submittal of an application for a modification to the Special Use Permit.

MINUTES OF OCTOBER 21, 2008

The Planning & Inspections Staff recommends approval of the request for R7.5 Residential and MXD Mixed Use Development/CUD Conditional Use District and Permit based on the following:

1. The request is not consistent with the 2010 Land Use Plan, which calls for low density residential; however the request, if approved, will allow for the protection of wetlands and allow for the same or similar type of development that has previously been approved; and
2. The *Ordinance-Related Conditions* approved by the County will remain in force.

There are no other suitable zoning districts to be considered for this site.

Case P08-54 Continued

**A motion was made by Vice-Chair Epler and seconded by Ms. Hall to approve the Conditional Use Permit as recommended by the staff after finding that when completed, the proposal: 1) will not materially endanger the public health and safety; 2) will not substantially injure the value of adjoining or abutting property; 3) will be in harmony with the area in which it is to be located; and 4) will be in conformity with the land use plan, thoroughfare plan or other plan officially adopted by the Board of Commissioners. Unanimous approval.**

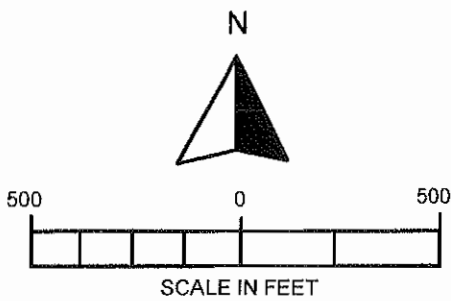
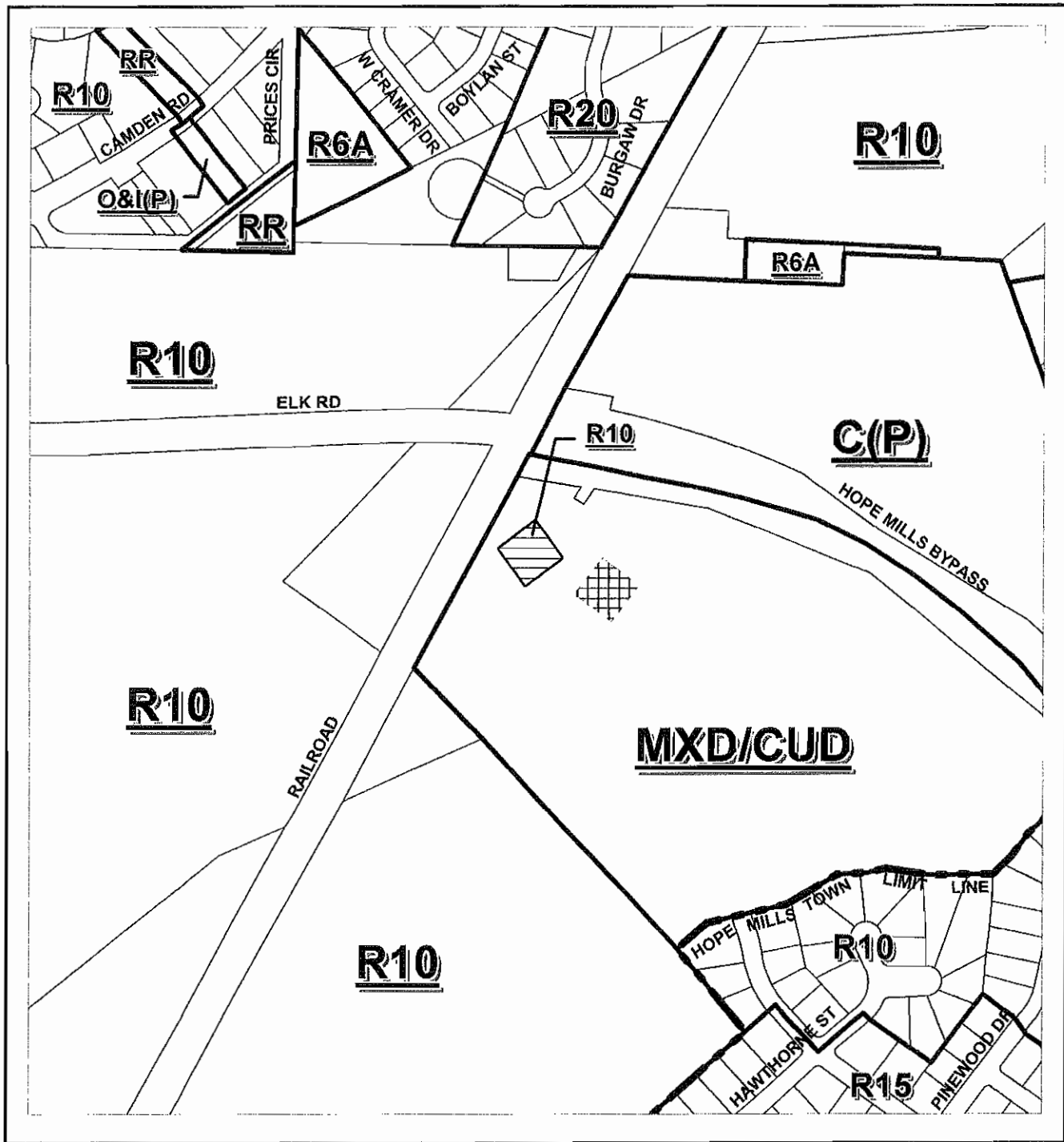

**REQUESTED REZONING**

**R10 TO MXD/CUD**

**MXD/CUD TO R7.5**



<b>ACREAGE: 0.52 AC. +/-</b>		<b>HEARING NO: P08-54</b>	
ORDINANCE: COUNTY	HEARING DATE	ACTION	
STAFF RECOMMENDATION			
PLANNING BOARD			
GOVERNING BOARD			

PIN: 0415-80-3461

AF  
9/26/08

TO THE CUMBERLAND COUNTY JOINT PLANNING BOARD AND THE BOARD OF COUNTY COMMISSIONERS OF CUMBERLAND COUNTY, NC:

I (We), the undersigned, hereby submit this application, and petition the County Commissioners to amend and to change the zoning map of the County of Cumberland as provided for under the provisions of the County Zoning Ordinance. In support of this petition, as hereinafter requested, the following facts are submitted:

1. APPLICANT/AGENT: FANETTEVILLE CHRISTIAN SCHOOL, INC  
*CO Applicant: American Towers Inc, Barry Cannon (770) 329-7422  
900 Circle 75 Parkway, Suite 300 Atlanta GA 30339*
2. ADDRESS: 1428 IRELAND DRIVE FAN, NC ZIP CODE: 28304
3. TELEPHONE: (Home) \_\_\_\_\_ (Work) 910-483-3905
4. Location of Property: HOPE MILLS BYPASS BETWEEN CAMDEN RD & LEGION RD.
5. Parcel Identification Number (PIN #) of subject property: 0415-80-3461 ~~\_\_\_\_\_~~  
(also known as Tax ID Number or Property Tax ID)
6. Acreage: ~~4.77~~ Frontage: 2260' Depth: 1300'
7. Water Provider: PWC
8. Septage Provider: PWC
9. Deed Book 6839, Page(s) 32, Cumberland County Registry. (Attach copy of deed of subject property as it appears in Registry).
10. Existing use of property: \_\_\_\_\_
11. Proposed use(s) of the property: Rezone 150'x150' MXD/CUD TO R10  
for telecommunication tower. Rezone Previous 150'x150' R10 to MXD/CUD

NOTE: Be specific and list all intended uses.

12. It is requested that the foregoing property be rezoned FROM: R10 TO MXD/CUD

TO: (select one)

- \_\_\_\_\_ Conditional Use District, with an underlying zoning district of \_\_\_\_\_ (Article V)
- \_\_\_\_\_ Mixed Use/Conditional Use District (Article VI) <sup>TO</sup> R10
- \_\_\_\_\_ Planned Neighborhood District/Conditional Use District (Article VII)
- \_\_\_\_\_ Density Development/Conditional Use District, at the \_\_\_\_\_ Density (Article VIII)

MXD to R10 → .52

R10 to MXD → .52

J.P.

Charles C. Morris  
Chair  
Town of Linden

Donovan McLaurin  
Vice-Chair  
Wade, Falcon & Godwin  
Garland C. Hostetter,  
Town of Spring Lake  
Harvey Cain, Jr.,  
Town of Stedman



## COUNTY of CUMBERLAND

*Planning and Inspections Department*

Nancy Roy, AICP  
Director  
Thomas J. Lloyd,  
Deputy Director

Clifton McNeill, Jr.,  
Roy Turner,  
Lori Epler,  
Sara E. Pifand,  
Cumberland County

December 20, 2005

Rev. Tracy Pounders  
3110 Doc Bennett Rd  
Fayetteville NC 28306

RE: P05-77: REZONING OF 45.74 ACRES FROM R10 TO A MIXED USE DEVELOPMENT/CONDITIONAL USE DISTRICT AND PERMIT, LOCATED SOUTH OF THE HOPE MILLS ROAD BYPASS, NORTH OF SYCAMORE DRIVE, SUBMITTED BY MATTHEW A. CRUMP, OWNED BY CROSSPOINTE CHURCH.

Dear Reverend Pounders:

The Cumberland County Board of Commissioners met on Monday, November 21, 2005, and approved the Mixed Use Development and Conditional Use Overlay District and Permit subject to the following conditions:

1. That the Public Works Commission approves water and sewer plans prior to application for any permits.
2. That applicant is advised that an expert on wetlands should be consulted before proceeding with any development.
3. That the owner(s)/developer(s) of these lots obtain detailed instructions on permits required to place a structure within this development from the Code Enforcement Section at 130 Gillespie Street, Room 106. The Code Enforcement Section will need a copy of this Approved Condition Sheet and map for additional information or the developer should call a Code Enforcement Officer at 321-6654.
4. That at a minimum a zoning permit is required prior to the placement of any structure on any portion of this development.
5. That no occupancy permit be issued until the Code Enforcement Officer inspects the site and certifies that the site is developed in accordance with the approved plans.
6. That a site-specific address and tax parcel number be provided at the time of building/zoning permit application.
7. That the developer provides the County Code Enforcement Section with an approved state sedimentation and erosion control plan prior to any application for permits.

8. That the signage for this development be in accordance with the applicable sign regulations as set forth in Article XIII of the County Zoning Ordinance and that the proper permit(s) be obtained prior to the installation of any permanent signs on the property. Note: This conditional approval is NOT approval of the size, shape, or location of any signs.
9. That all uses and setbacks be compatible with those permitted and approved for the MXD/CUD zoning classification.
10. That all applicable portions of Section 3.20 "Lot Standards" and 3.21 "Group Development", of the County Subdivision Ordinance be complied with.
11. That the developer shall contact Diane Shelton at 678-7665 for street name approval prior to submission of the final plat for approval. (Note: The approved street name shall be reflected on the final plat.)
12. That street name signs, in compliance with the Cumberland County Street Sign Specifications, shall be installed prior to final plat approval. The developer is responsible for contacting 678-7665, once the street name sign(s) are installed, to schedule an inspection of said sign(s) and notice of a satisfactory inspection must be received by Land Use Codes prior to the approval of the final plat.
13. That Sections 4.1.c, "Curb and Gutters", 4.1.d, "Required Drainage", 4.1.e, and 4.3.g, "Fire Hydrants", and 4.3.h "Underground Utilities", of the Cumberland County Subdivision Ordinance must be adhered to.
14. That the final plat must be submitted to the Land Use Codes Section for review and approval for recording; and that the plat must be recorded prior to any permit application on any structure and/or prior to the sale of any lot or unit in this development.
15. That any/all easements appear on the final plat.
16. That all structures shall be shown on the final plat or that the final plat shall reflect the following statement:

"Nonconforming structures have not been created by this subdivision."
17. That notarized owners' signature(s) and certifications appear on the final plat prior to approval.
18. That the NC Department of Transportation approves street plans and that the street(s) be constructed to the N.C. Department of Transportation standards for secondary roads.
19. That the NC Department of Transportation stamp be affixed to the final plat prior to final plat approval by the Land Use Codes Section.
20. That the developer needs to obtain a driveway permit from the NC Department of Transportation.
21. Turn lanes may be required by NC Department of Transportation.
22. That a 10' x 70' sight distance easement shall be required at the intersection of the Hope Mills Bypass and the proposed right-of-way.
23. That a 25' right-of-way radius shall be required at all intersections.

24. That all lighting shall be directed internally to the property and shall meet the standards of Section 1102.M, Outdoor Lighting, Cumberland County Zoning Ordinance.
25. That a solid buffer in accordance with Section 1102.G., Cumberland County Zoning Ordinance, be complied with.
26. The developer shall submit two copies of a revised plan to the Land Use Codes Staff for approval showing the location of all dumpster, garbage, and utility areas prior to permits being issued.
27. That all dumpster, garbage, and utility areas shall be located on concrete pads and screened on a minimum of three sides.
28. That all required parking spaces shall be a minimum of 9' X 20' and shall be surfaced and striped with a permanent material such as asphalt or concrete.
29. That off-street loading areas shall be provided in accordance with Section 1203, County Zoning Ordinance, and that a revised plan showing the required loading spaces shall be submitted to the Land Use Codes Section for approval prior to any permits being issued.
30. That the owner/developer is responsible and liable for maintenance and upkeep of this site, all structures, and appurtenances, to include insuring that the site is kept free of litter and debris, all grass areas mowed, all buffers and shrubbery kept trim and maintained, so that the site remains in a constant state of being aesthetically and environmentally pleasing.
31. That the developer not be required to connect to the street stub shown as "Sycamore Drive" in the adjacent subdivision since this portion of the right-of-way is blocked and the developments are naturally separated by a creek.
32. That the site be developed in accordance with the application and site plan.
33. That all Federal, State, and local regulations be complied with.

In addition to the approval by the Board of Commissioners, a permit is required to be obtained from the Code Enforcement Section, Planning and Inspections Department. They are located at 130 Gillespie Street, Room 101 and can be reached at 321-6654.

Sincerely,

- 5 -

Patti Speicher, Supervisor  
Land Use Codes Section

signed and mailed per Annette 3-28-06



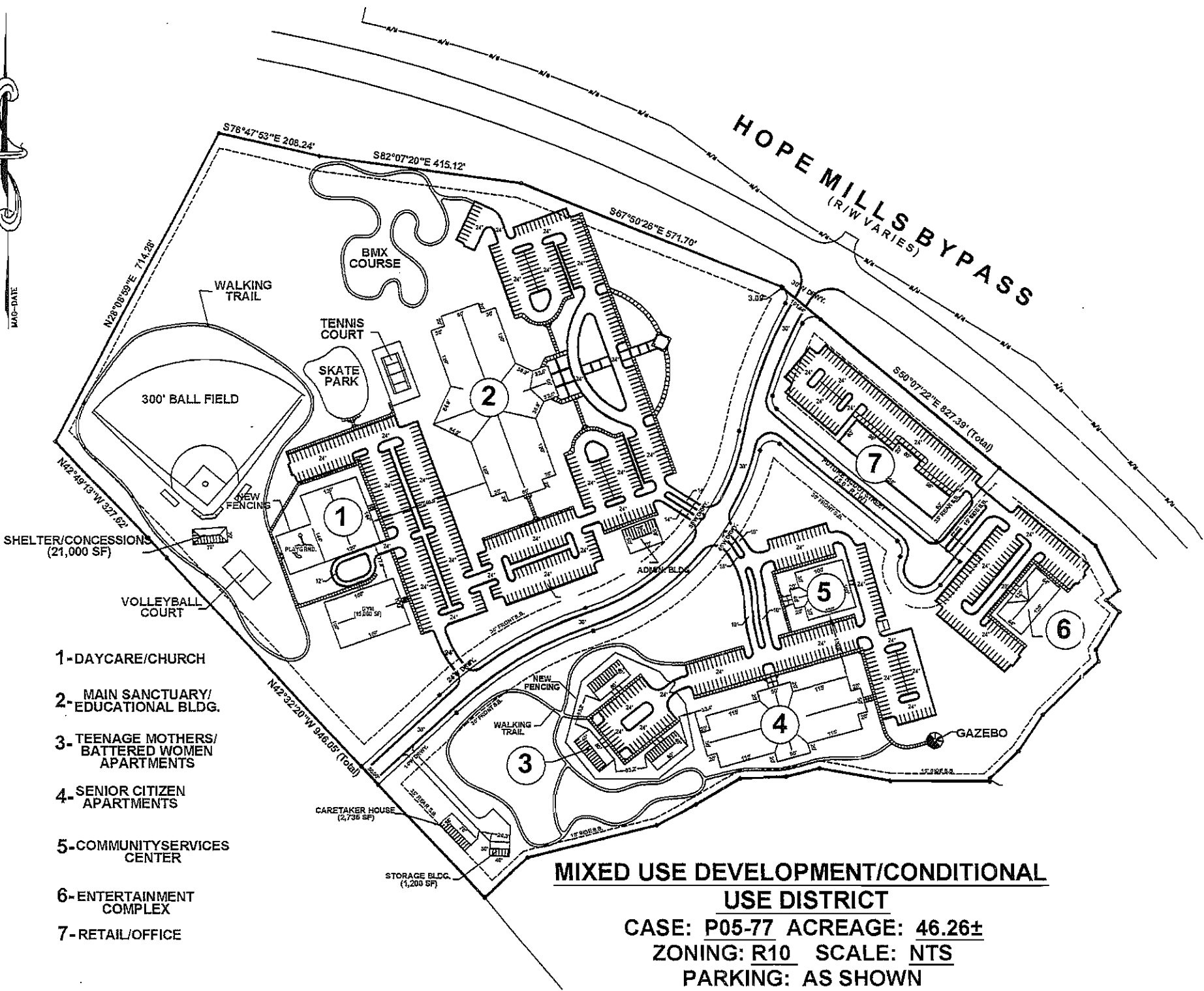

- 1- DAYCARE/CHURCH
- 2- MAIN SANCTUARY/  
EDUCATIONAL BLDG.
- 3- TEENAGE MOTHERS/  
BATTERED WOMEN  
APARTMENTS
- 4- SENIOR CITIZEN  
APARTMENTS
- 5- COMMUNITY SERVICES  
CENTER
- 6- ENTERTAINMENT  
COMPLEX
- 7- RETAIL/OFFICE

**MIXED USE DEVELOPMENT/CONDITIONAL  
USE DISTRICT**  
CASE: P05-77 ACREAGE: 46.26±  
ZONING: R10 SCALE: NTS  
PARKING: AS SHOWN

## MOTIONS ON CONDITIONAL USE DISTRICT REZONING APPLICATIONS

### IF TO APPROVE CONDITIONAL USE DISTRICT:

I MOVE THAT THE BOARD OF COMMISSIONERS FINDS THAT THIS CONDITIONAL USE DISTRICT APPLICATION IS REASONABLE, NEITHER ARBITRARY NOR UNDULY DISCRIMINATORY, AND IN THE PUBLIC INTEREST, AND THAT THE CONDITIONAL USE(S) BE APPROVED OR DELETED AS DESCRIBED IN THE STAFF AGENDA MEMORANDUM:

---

### IF TO DENY CONDITIONAL USE DISTRICT:

I MOVE THAT THE BOARD OF COMMISSIONERS FAILS TO FIND THAT THIS CONDITIONAL USE DISTRICT APPLICATION IS REASONABLE, NEITHER ARBITRARY NOR UNDULY DISCRIMINATORY, AND IN THE PUBLIC INTEREST, AND THAT IT THEREFORE BE DENIED.

**[\*\*\*\*IF CONDITIONAL USE DISTRICT IS DENIED, DO NOT MAKE ANY MOTION ON CONDITIONAL USE PERMIT].**

### IF TO APPROVE CONDITIONAL USE PERMIT:

I MOVE THAT THE BOARD OF COMMISSIONERS FINDS THAT THIS CONDITIONAL USE PERMIT APPLICATION, IF COMPLETED AS PROPOSED AND SUBJECT TO THE CONDITIONS RECOMMENDED BY THE PLANNING BOARD:

- (I) WILL NOT MATERIALLY ENDANGER THE PUBLIC HEALTH AND SAFETY, AND
- (II) WILL NOT SUBSTANTIALLY INJURE THE VALUE OF ADJOINING OR ABUTTING PROPERTY, AND
- (III) WILL BE IN HARMONY WITH THE AREA IN WHICH IT IS TO BE LOCATED, AND
- (IV) WILL BE IN CONFORMITY WITH THE LAND USE PLAN, THOROUGHFARE PLAN OR OTHER PLAN OFFICIALLY ADOPTED BY THE BOARD OF COMMISSIONERS.

October 22, 2007

Donovan McLaurin,  
Chair  
Wade, Falcon & Godwin

Lori Epler,  
Vice-Chair  
Cumberland County

Garland C. Hostetter,  
Town of Spring Lake  
Harvey Cain, Jr.,  
Town of Stedman  
Patricia Hall,  
Town of Hope Mills  
Charles C. Morris,  
Town of Linden

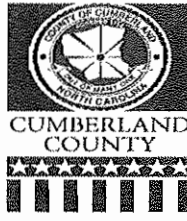

## CUMBERLAND COUNTY

# COUNTY of CUMBERLAND

*Planning and Inspections Department*

Thomas J. Lloyd,  
Director

Cecil P. Combs,  
Deputy Director

Walter Clark,  
Roy Turner,  
Sara E. Piland,  
Cumberland County

Benny Pearce,  
Town of Eastover

NOVEMBER 7, 2008

ITEM NO. 3D

MEMO TO: Cumberland County Board of Commissioners

FROM: Cumberland County Joint Planning Board

SUBJECT: **Case P08-40:** Rezoning of 0.81+/- acres from M(P) Planned Industrial/CUD Conditional Use District (to allow the manufacturing and sales of storage buildings) and the Permit to C(P) Planned Commercial or to a more restrictive zoning district, located at 5003 Marracco Drive, submitted by Michael N. Nelson & Michael Adams, owned by John D. Graham & Columbia O. Blanks.

ACTION: Members present at the October 21, 2008 meeting voted unanimously to recommend approval of Conditional Use Permit, the Board also approved motor vehicle sales and trailer rentals.

SITE INFORMATION: **Frontage & Location:** 720.00'+/- on Marracco Drive; 690.00'+/- on US HWY 301 S; **Depth:** 150.00'+/-; **Jurisdiction:** Cumberland County; **Adjacent Property:** No; **Current Use:** Manufacture & sale of storage buildings; staff informed the applicant that "manufacturing" is not a permitted use in the C(P) district; **Initial Zoning:** C(P) – June 25, 1980 (Area 13); Rezoned to M(P)/CUD September 19, 2005; **Nonconformities:** Partially constructed block building not approved for the CUD; if approved, manufacturing of storage buildings would be nonconforming use; **Zoning Violation(s):** None; **Surrounding Zoning:** North: RR, R6A & C3; East: RR, RR/CU (to allow a commercial warehousing as an off-site storage facility) & M(P); South: RR, R6A, C3/CU (to allow residential uses in C3 heavy commercial district), M(P), M2 & C(P) (County/Hope Mills); West: RR & C(P); **Surrounding Land Use:** Religious worship facility, truck terminal activities, mini-warehousing, sales and storage equipment, and woodlands; **2010 Land Use Plan:** Medium density residential; **Special Flood Hazard Area (SFHA):** None; **Water/Sewer Availability:** PWC/Septic; **Soil Limitations:** None; **School Capacity/Enrolled:** Gallberry Farm Elementary: 900/1,077; South View Middle: 911/880; Grays Creek High: 1,270/1,145; **Subdivision/Site Plan:** See attached "Ordinance-Related Conditions"; **Municipal Influence Area:** Town of Hope Mills; **Average Daily Traffic Count (2006):** 14,000 on US HWY 301 S; 4,500 on Marracco Drive; **Highway Plan:** There are no road improvements/constructions specified for this area. This case has no impact on the current Highway Plan or Transportation Improvement Program; **Note:** Building envelope contains approximately 492.90+/- square feet; **Requested Permitted Uses:** Apparel & Accessory Sales, Motor Vehicle Parts & Accessories, Locksmith, Gunsmith, Motor Vehicle Repair and/or Body Work, Motor Vehicle Sales, Mini-warehousing (Self-Storage Facility), Motor Vehicle Storage Yard, Office Use, Photography Studio, Restaurant, Repair, Rental & Servicing, Second Hand Pawn & Flea Market, Retail or Servicing, Trailer Rentals, Trades Contractor Activities, Variety, Gift & Hobby Supply Sales, Wholesale Sales

Case P08-40 Continued

MINUTES OF OCTOBER 21, 2008

Mr. Lloyd reviewed the site information and stated the staff recommends approval of the request for C(P) Planned Commercial/Conditional Use District for retail and other permitted uses; however, the staff does not recommend approval of all the requested uses; the staff's recommended allowable uses for this district are:

- |                               |                                       |
|-------------------------------|---------------------------------------|
| a. Apparel & Accessory Sales  | e. Retail or Servicing                |
| b. Locksmith, Gunsmith        | f. Office Use                         |
| c. Photography Studio         | g. Restaurant                         |
| d. Repair, Rental & Servicing | h. Variety, Gift & Hobby Supply Sales |

This recommendation is based on the following:

1. Even though the C(P) Planned Commercial district is not consistent with the 2010 Land Use Plan, which calls for medium density residential at this location, the recommendation is reasonable because the area is in transition to non-residential uses; and
2. The recommendation would allow for uses appropriate within an *entrance corridor* to both the County and the Town of Hope Mills.

The C1(P) Planned Local Business and C2(P) Planned Service and Retail districts could also be found suitable at this location.

The Planning & Inspections Staff also recommends approval of the Conditional Use Permit based on the following:

1. The recommended use will not materially endanger the public health and safety if located according to the site plan submitted;
2. The use will meet all required conditions and specifications if constructed according to the site plan, application and conditions – a copy of the *Ordinance-Related Conditions* pertaining to this site is attached; and
3. The location and character of the use, if developed according to the site plan as submitted, will be in harmony with the area in which it is to be located.

Inherent in this recommendation, the Planning & Inspections Staff recommends that the Permit be restricted so that any use allowed cannot generate outside display and/or outside storage at this location.

Vice-Chair Epler asked for clarification purposes, if the requested uses that Mr. Lloyd read were the requested permitted uses, not what the planning staff recommends.

Mr. Lloyd stated that was correct.

Mr. Lloyd stated that the Planning & Inspections staff has no problem with the uses listed in the recommendation, but because this is an entrance corridor and the size and shape of the lot, more specifically the size of the lot, buffering would be virtually non-existent. For that reason we feel that any outside display or storage wouldn't be appropriate at this location.

Mr. Morris stated that this request doesn't comply with any of our existing setbacks. If the site plan is approved will a variance be provided for the setback?

Case P08-40 Continued

Mr. Lloyd stated no, the site plan as submitted will be approved by the conditional use permit, which essentially grants an alternate yard requirement for the setbacks.

Mr. Morris stated that we're granting a variance to the existing setbacks.

Mr. Lloyd stated in essence that was correct.

Micheal Nelson stated that he would prefer not to be sworn in because he is a pastor. Chair McLaurin had Mr. Nelson affirm to tell the truth.

Chair McLaurin swore in Mr. John Dawson Graham.

Mr. Nelson spoke in favor. Mr. Nelson stated that he is the applicant, and appreciates all the work that has been done on this. This piece of property is totally encompassed by highway. There is Department of Transportation property completely surrounding the subject property. Mr. Nelson stated that he concurs with what was approved, but would like to ask for some other approvals. He was advised that going through the conditional use process he would need any approval for any future uses he may have. Mr. Nelson stated that currently he is a licensed and bonded North Carolina car dealer. The vehicles that he sells are quality merchandise which is kept inside. Mr. Nelson stated that he feels he is being denied usage of some of these items which are already concurrently being used around this piece of property. Mr. Nelson stated that basically he agrees with what has been approved, but would like to also be able to use his motor vehicle dealer's license there. Mr. Nelson stated that he doesn't plan on storing vehicles at this location; a fence has been placed on the property where he may display vehicles if it's ever needed, because there is a theft problem in the area. Mr. Nelson plans to clean the property up, removing and tearing down some unsightly buildings that are on the property. This will improve the tax base and also improve the gateway into Fayetteville. Mr. Nelson stated that he can't see any reason why he can't have some of the requested uses. He has no plans to deface the County; he would just like to improve upon his chances for a successful business.

Chair McLaurin stated that when requesting a conditional use you're asking for special consideration and for that consideration you greatly reduce the uses and generally we know exactly what you are going to do. The conditional use was designed for special needs.

Mr. Lloyd stated that in the past, any use that the applicant feels they may want to do in the future has to be considered now.

Mr. Nelson stated that he was advised that he should list any uses that he might use it for. He was told a conditional use would have better success than a total rezoning to C(P). It is at present a more restrictive zoning, in fact it's M(P) Manufacturing with C(P), which already has display on it. I am actually putting it at a better use with what is being recommended.

Chair McLaurin asked if under the present zoning how many uses you have.

Mr. Nelson responded a manufacturing site for storage buildings and sales and other miscellaneous things.

Mr. Lloyd stated that Mr. Graham is the owner and Mr. Nelson is the prospective buyer.

Chair McLaurin stated that generally when a conditional use is granted here we usually know, within reason, what is going to be taking place. You have uses that vary greatly.

Mr. Nelson stated that the only reason he listed those uses was because it was recommended that he do so.

Case P08-40 continued

Vice-Chair Epler asked Mr. Nelson about the statement he made about keeping his vehicles inside.

Mr. Nelson responded that presently he keeps all of his vehicles stored indoors in Cumberland County.

Vice-Chair Epler clarified that the vehicles are displayed indoors.

Mr. Nelson responded yes indoors, they are specialty cars, they are not normal cars. But he wants to be able to display the cars outdoors for sale. There is a problem in the area with theft and the plans are to place fencing up.

Vice-Chair Epler asked about Mr. Nelson's statement to enhance the property. Vice-Chair Epler asked if he was going to keep the existing building.

Mr. Nelson stated that he was going to tear down about three structures that are on the property now and remove other debris.

Ms. Hall asked Mr. Nelson about his indication of wanting motor vehicle sales, the question was can he have sales without storage.

Mr. Nelson responded that what he needs is sales. He feels that he should have the capability to conduct sales. Mr. Nelson stated that he was advised that he should list any uses that the property might be used for in ten years, and that's what he did.

Ms. Hall asked if motor vehicle sales covered retail and wholesale.

Mr. Lloyd stated that it does.

Ms. Hall stated that wholesale wouldn't be needed, just sales.

Mr. Graham spoke in favor. Mr. Graham stated that he was present to answer any questions that the Board may have. Mr. Graham stated that it was his understanding that what was on the property now needs to be removed.

Vice-Chair Epler asked Mr. Graham if he lived down the street from the subject property.

Mr. Graham stated that was correct.

Vice-Chair Epler asked if he was aware of the permitted uses that were being asked for and if he would continue to be a neighbor of the property and if there were any uses that he would have a problem with as a neighbor.

Mr. Graham stated no. He stated that he had been in the area for twenty years, and he doesn't believe anyone would oppose.

Public hearing closed.

Mr. Morris stated that it worries him that we would provide all of these variances.

Vice-Chair Epler asked if the landscape requirement could be met with the current site plan.

Mr. Lloyd stated that they should be with the setback waivers.

Vice-Chair Epler stated that in granting the waivers we are not granting a variance to the landscaping ordinance.

Case P08-40 Continued

Mr. Lloyd stated no.

Mr. Morris asked if a waiver was being created with the parking at four thousand square feet and seventeen parking places.

Mr. Lloyd stated no, the parking, unless specifically listed which is just the dimensional uses, the other requirements can be met, with the waiver on the setbacks.

Mr. Morris asked what the current setbacks are.

Mr. Lloyd stated the setbacks are 50' for the front and 30' for the side and rear.

Mr. Morris stated that his dilemma is if we don't do something with the property it will become a wasteland and will stay that way. The other thing is if we start using site plans to create waivers and variances than we open Pandora's box. We need to be clear on that.

Mr. Turner asked how many residences are around the subject property and were they notified about this case.

Mr. Lloyd stated that thirty-five addresses were notified.

Ms. Hall asked Mr. Lloyd if the applicant could, with the C(P)/CUD with limited uses including the motor vehicle sales come back at a later date and request something else.

Mr. Lloyd responded that the applicant could do that.

Mr. Morris asked what the speed limit was in the area.

Chair McLaurin stated it was 45 on Marracco Dr. and 55 on Highway 301.

Vice-Chair Epler stated that she would really like to see this property improve. She doesn't necessarily agree with all of the requested permitted uses, some of those we might be able to include and add to the staff recommendations. I don't have a problem adding motor vehicle sales or trailer rentals. The rest of the requests, even though there is mini-warehousing and storage facilities in that area, I don't feel the site is large enough to add those. We don't typically see those on a site this small. I'm afraid if that business were

tried on this area it might not make it and we would end up with another dark building. I would like to see that property improve and I don't have a problem adding those two uses to the ones that the staff has recommended. I understand his desire to watch out for his future as a business owner and the future of his family that he may leave this to someday, but we also have to see this from the point that you may decide that five years from now this site isn't working for you and your son may decide that he doesn't want to use it either, we have to keep in mind that what we approve here tonight may go to someone that doesn't have quite as noble motives as you do down the road. We really have to watch out for that neighborhood and that corridor into our town and into our County.

**A motion was made by Vice-Chair Epler and seconded by Ms. Hall to approve the Conditional Use Permit as recommended by the staff for apparel & accessory sales, locksmith, gunsmith, photography studio, repair, rental & servicing, retail or servicing, office use, restaurant, and variety, gift & hobby supply sales, the Board also recommends approval of the uses of motor vehicle sales and trailer rentals after finding that when completed, the proposal: 1) will not materially endanger the public health and safety; 2) will not substantially injure the value of adjoining or abutting property; 3) will be in harmony with the area in which it is to be located; and 4) will be in conformity with the land use plan, thoroughfare plan or other plan officially adopted by the Board of Commissioners. Unanimous approval.**

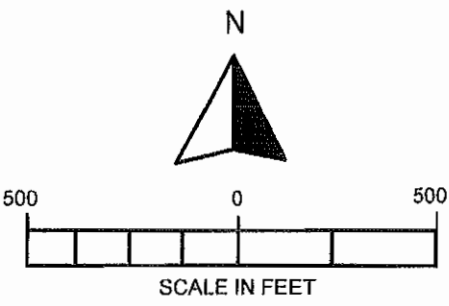
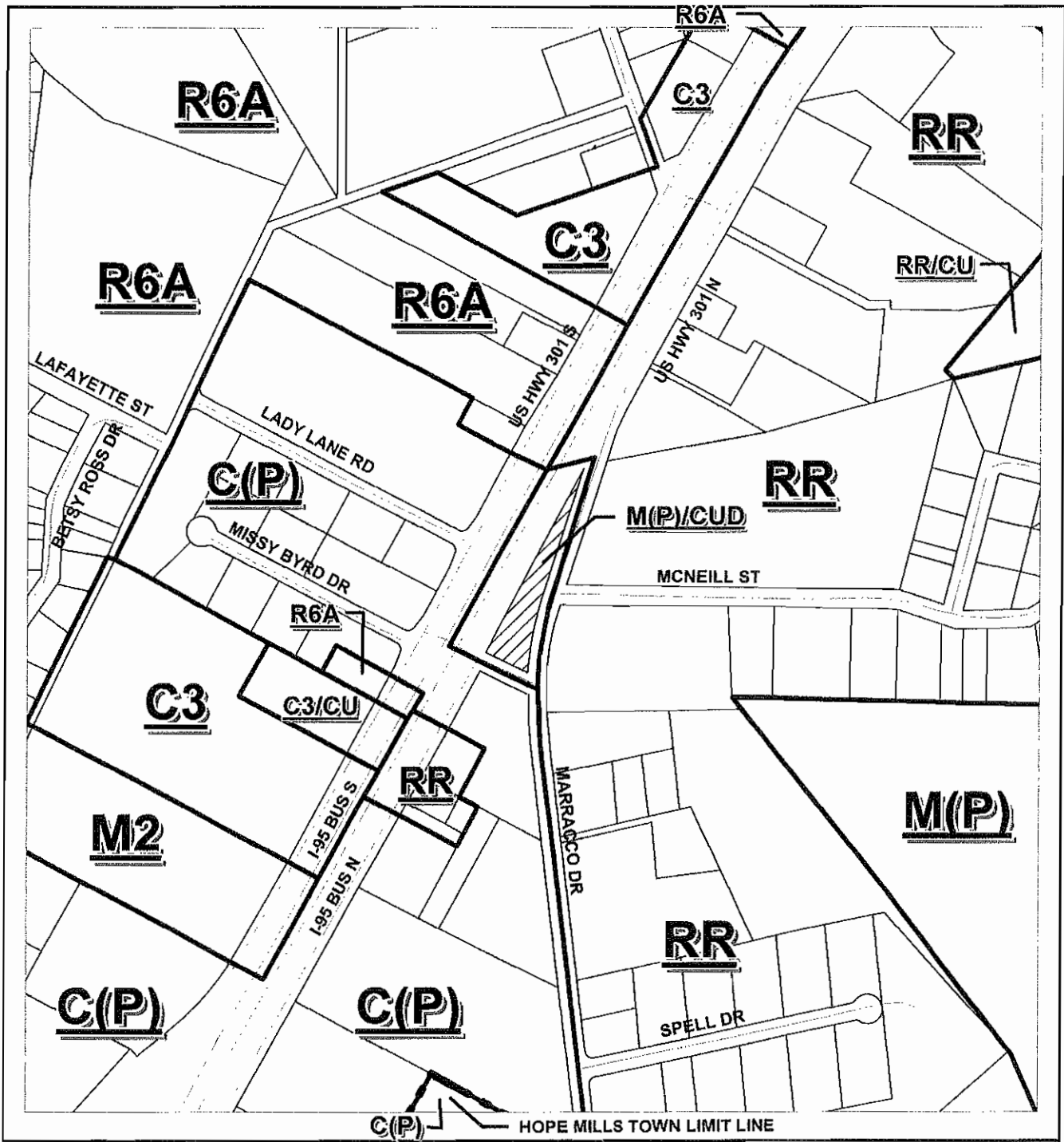

PIN: 0423-27-1139

## REQUESTED REZONING M(P)/CUD TO C(P)/CUD

<b>ACREAGE: 0.81 AC.+/-</b>	<b>HEARING NO: P08-40</b>	
ORDINANCE: COUNTY	HEARING DATE	ACTION
STAFF RECOMMENDATION		
PLANNING BOARD		
GOVERNING BOARD		



I-95 BUSINESS SOUTH/US HWY 301 SOUTH  
PUBLIC R/W VARIES

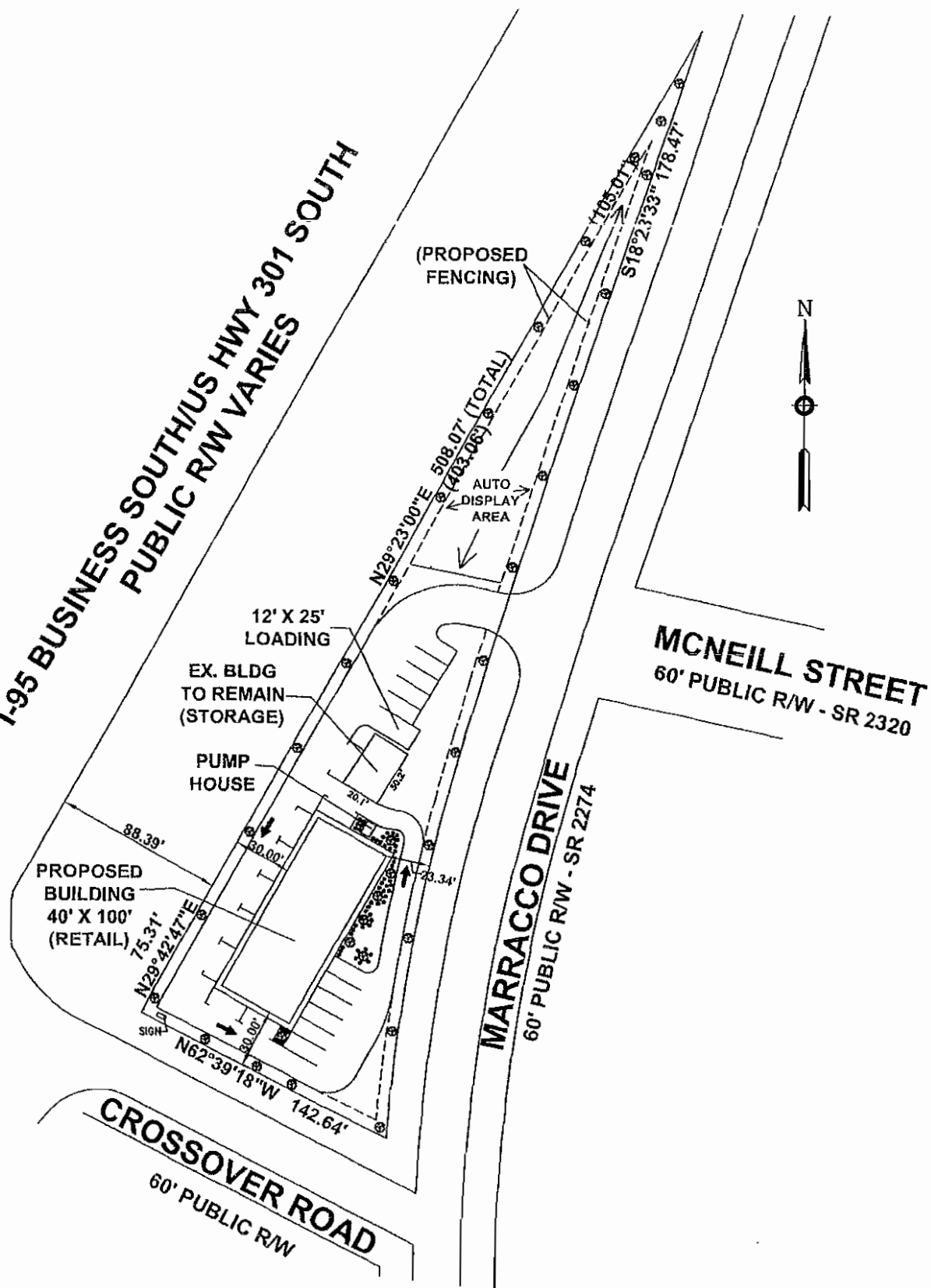

**CONDITIONAL USE DISTRICT AND PERMIT**

REQUEST: RETAIL AND OTHER PERMITTED USES

CASE: P08-40 ACREAGE: 0.81±

ZONED: M(P)/CUD SCALE: NTS

PARKING: AS SHOWN

\*SCALED, DETAILED SITE PLAN IN FILE AVAILABLE FOR REVIEW UPON REQUEST

**Conditional Use District & Permit  
Ordinance Related Conditions**

**Pre-Permit Related:**

1. Prior to application for any permits, the storage building manufacturing and sales currently approved for this site must have ceased with all display buildings removed from the site.
2. Prior to application for any permits, the developer must submit for staff site plan review and approval for the initial uses(s) and also submit for re-approval of any subsequent change in use(s).

**Permit-Related:**

3. The owner/developer(s) of these lots must obtain detailed instructions on provisions of the County Zoning Ordinance and permits required to place any structure within this development from the County Code Enforcement Section, Room 101 in the Historic Courthouse at 130 Gillespie Street. For additional information, the developer should contact a Code Enforcement Officer.
4. The County Health Department must approve sewer plans prior to application for any permits. Site and soil evaluations must be conducted on the property by the County Environmental Health Department prior to application for permits. A copy of the Health Department approval must be provided to Code Enforcement at the time of application for any building/zoning permits. (Note: All Health Department requirements must be met prior to issuance of final permits.) (Section 2306 A, Water and Sewer, County Subdivision Ordinance)
5. Connection to public water is required; the Public Works Commission (PWC) must approve water plans prior to application for any permits. A copy of the PWC approval must be provided to Code Enforcement at the time of application for building/zoning permits. (Section 2306 A.1, Public Water and Sewer Systems County Subdivision Ordinance)
6. The developer must provide a site-specific address and tax parcel number at the time of building/zoning permit application.
7. Landscaping must be provided in accordance with Section 1102 N, Landscaping, County Zoning Ordinance and/as shown on the site plan. The following are the minimum standards for the required landscaping of this site:
  - a. Twelve large shade trees or 23 small ornamental trees within the front yard setback area along US HWY 301 (Gillespie Street);
  - b. Three large shade trees or six small ornamental trees within the front yard setback area along Crossover Road;
  - c. Twelve large shade trees or 24 small ornamental trees within the front yard setback area along SR 2274 (Marracco Drive);
  - d. Five ornamental trees and 48 shrubs are required in the building yard area;
  - e. One large shade tree or two small ornamental trees are required within the parking area.

**In addition:**

- a. Required plant materials shall be maintained by the property owner, including replacing dead or unhealthy trees and shrubs.
  - b. All yard and planting areas shall be maintained in a neat, orderly, and presentable manner and kept free of weeds and debris.
8. The building final inspection cannot be accomplished until a Code Enforcement Officer inspects the site and certifies that the site is developed in accordance with the approved plans.

**Site-Related:**

9. All uses, dimensions, setbacks and other related provisions of the County Subdivision and Zoning Ordinances for the C(P)/CUD zoning district must be complied with, as applicable.

Note: See case file, minutes of the meetings and the final approval letter for restricted list of allowable uses.

10. This conditional approval is not approval of the permit for the freestanding sign. Attached signage for this development must be in accordance with the applicable sign regulations as set forth in Article XIII of the County Zoning Ordinance and that the proper permit(s) must be obtained prior to the installation of any permanent signs on the property. (Note: This conditional approval is **not** approval of the size, shape, or location of any signs.)
11. For all new development, an adequate drainage system must be installed by the developer in accordance with the NC Department of Environment and Natural Resources' (NCDENR) *Manual on Best Management Practices* and all drainage ways must be kept clean and free of debris. (Section 2306 D, County Subdivision Ordinance)
12. For all new construction, all utilities, except for 25kv or greater electrical lines, must be located underground. (Section 2306 C, County Subdivision Ordinance)
13. The developer must obtain a driveway permit from the NC Department of Transportation (NCDOT). A copy of the approved driveway permit must be provided to Code Enforcement at the time of application for building/zoning permits.
14. All lighting is required to be directed internally within this development and comply with the provisions of Section 1102 M, Outdoor Lighting, County Zoning Ordinance.
15. All dumpster, garbage, and utility areas shall be located on concrete pads and screened on a minimum of three sides.
16. All required off-street parking spaces shall be a minimum of 9' x 20' and shall be surfaced, with a permanent material such as asphalt or concrete, and striped prior to application for the building final inspection. A minimum of 20 off-street parking spaces are required for this development.
17. A minimum of one off-street loading space measuring 12' x 25' with a 14' overhead clearance is required to be provided for this development.
18. In the event a use is approved that would allow for outside open storage, the outside storage area must be completely screened from view from any public right-of-way; chain link fencing cannot be used to satisfy the buffer requirement. (Sec. 1102.G, County Zoning Ordinance) (Note: **The staff recommendation is for no outside storage and no outside display to be permitted on this site.**)
19. All notes and calculations as shown on the site plan are to be considered as a part of this conditional approval.

**Other Relevant Conditions:**

20. Any changes to the desired uses require re-submittal and re-approval by the County Board of Commissioners for the Conditional Use District; any changes to the Permit, including the site plan and/or layout of this site, must be submitted for review and approval and dependant upon the extent of the approval may require re-submission to the County Board of Commissioners.
21. The applicant is advised to consult an expert on wetlands before proceeding with any development.
22. The owner/developer is responsible for ensuring easements which may exist on the subject property are accounted for, not encumbered and that no part of this development is violating the rights of the easement holder.

23. Every deed created for a lot being served by an on-site water and/or sewer system must contain the following disclosure when filed with the County Register of Deeds:

“Public water and/or sewer services are not available as of the date of the recording of this deed. On-site sewer disposal systems must be approved by the County Health Department.”

**If you need clarification of any conditions, please contact Ed Byrne at 910-678-7609 or Patti Speicher at 910-678-7605; otherwise, contact the appropriate agency at the contact numbers below.**

Contact Information (Area Code is 910 unless otherwise stated):

Subdivision/Site Plan/Plat	Ed Byrne	678-7609
Code Enforcement (Permits):	Ken Sykes	321-6654
County Health Department:	Danny Soles	433-3685
PWC:	Heidi Maly	223-4773
Town of Hope Mills:		424-4555*
Corp of Engineers (wetlands):	Ronnie Smith	(910) 251-4829
NCDENR (E&S):	Sally McKinney	433-3300
E911 Site-Specific Address:	Ron Gonzales	678-7616
Tax Parcel Numbers:		678-7549
NCDOT (driveways/curb-cuts):	Gary Burton	486-1496
N.C. Division of Water Quality:	Mike Randall	(919) 733-5083 ext. 545

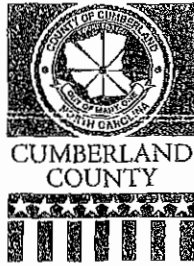

## COUNTY of CUMBERLAND

Planning & Inspections Department

CASE #:	<u>PO8-40</u>
PLANNING BOARD	<u>21 Oct 08</u>
MEETING DATE:	<u>16 Sep 08</u>
DATE APPLICATION	<u>16 Sep 08</u>
SUBMITTED:	<u>17 July 08</u>
RECEIPT #:	<u>Handwritten 59849</u> <u>RECEIPT</u>
RECEIVED BY:	<u>PBB</u>

### APPLICATION FOR REZONING REQUEST CUMBERLAND COUNTY ZONING ORDINANCE

The following items are to be submitted with the completed application:

1. A copy of the *recorded* deed and/or plat.
2. If a portion(s) of the property is being considered for rezoning, an accurate written legal description of only the area to be considered;
3. A check made payable to "Cumberland County" in the amount of \$ 400.00.  
(See attached Fee Schedule).

Rezoning Procedure:

1. Completed application submitted by the applicant.
2. Notification to surrounding property owners.
3. Planning Board hearing.
4. Re-notification of interested parties / public hearing advertisement in the newspaper.
5. County Commissioners' public hearing (approximately four weeks after Planning Board public hearing).
6. If approved by the County Commissioners, rezoning becomes effective immediately.

The Planning & Inspections Staff will advise on zoning options, inform applicants of development requirements and answer questions regarding the application and rezoning process. For further questions, call (910) 678-7603 or (910) 678-7609. Hour of operation are 8:00 a.m. to 5:00 p.m., Monday through Friday.

NOTE: Any revisions, inaccuracies or errors to the application may cause the case to be delayed and will be scheduled for the next available Board meeting according to the Board's meeting schedule. Also, the application fee is *nonrefundable*.

TALKED WITH OWNER ABOUT CHANGING THE EXISTING COD  
IN ORDER TO TAKE CARE OF THE SETBACKS FOR THE EXISTING OR  
PROPOSED BUILDINGS ON SEVERAL OCCASIONS  
8-18-08

TO THE CUMBERLAND COUNTY JOINT PLANNING BOARD AND THE BOARD OF COUNTY COMMISSIONERS OF CUMBERLAND COUNTY, NC:

I (We), the undersigned, hereby submit this application, and petition the County Commissioners to amend and to change the zoning map of the County of Cumberland as provided for under the provisions of the County Zoning Ordinance. In support of this petition, the following facts are submitted:

1. Requested Rezoning from M(P)/CUD to C(P)
2. Address of Property to be Rezoned: 5003 Marracco Drive
3. Location of Property: Intersection of Marracco Drive and  
US Hwy 301
4. Parcel Identification Number (PIN #) of subject property: 0423-27-1139  
(also known as Tax ID Number or Property Tax ID)
5. Acreage: 0.811 Ac Frontage: 1323.50 Depth: 142.64
6. Water Provider: Well  PWC \_\_\_\_\_ Other (name) \_\_\_\_\_
8. Septage Provider: Septic Tank  PWC \_\_\_\_\_
9. Deed Book 6062, Page(s) 642, Cumberland County Registry. (Attach copy of deed of subject property as it appears in Registry).
10. Existing use of property: Manufacturing Sheds
11. Proposed use(s) of the property: Retail (Car Sales / Sporting Goods)
12. Do you own any property adjacent to or across the street from this property?  
Yes \_\_\_\_\_ No  If yes, where? \_\_\_\_\_
13. Has a violation been issued on this property? Yes \_\_\_\_\_ No

A copy of the recorded deed(s) and/or recorded plat map(s) must be provided. If the area is a portion of a parcel, a written legal description by metes and bounds, showing acreage must accompany the deed and/or plat. If more than one zoning classification is requested, a correct metes and bounds legal description, including acreage, for each bounded area must be submitted.

*The Planning and Inspections Staff is available for advice on completing this application; however, they are not available for completion of the application.*

Receipt # 52849

TO THE CUMBERLAND COUNTY JOINT PLANNING BOARD AND THE BOARD OF COUNTY COMMISSIONERS OF CUMBERLAND COUNTY, NC:

I (We), the undersigned, hereby submit this application, and petition the County Commissioners to amend and to change the zoning map of the County of Cumberland as provided for under the provisions of the County Zoning Ordinance. In support of this petition, as hereinafter requested, the following facts are submitted:

1. APPLICANT/AGENT: \_\_\_\_\_
2. ADDRESS: \_\_\_\_\_ ZIP CODE: \_\_\_\_\_
3. TELEPHONE: (Home) \_\_\_\_\_ (Work) \_\_\_\_\_
4. Location of Property: \_\_\_\_\_
5. Parcel Identification Number (PIN #) of subject property: \_\_\_\_\_  
(also known as Tax ID Number or Property Tax ID)
6. Acreage: \_\_\_\_\_ Frontage: \_\_\_\_\_ Depth: \_\_\_\_\_
7. Water Provider: \_\_\_\_\_
8. Septage Provider: \_\_\_\_\_
9. Deed Book \_\_\_\_\_, Page(s) \_\_\_\_\_, Cumberland County Registry. (Attach copy of deed of subject property as it appears in Registry).
10. Existing use of property: \_\_\_\_\_
11. Proposed use(s) of the property: \_\_\_\_\_

**NOTE: Be specific and list all intended uses.**

12. It is requested that the foregoing property be rezoned FROM: MP

- TO: (select one)
- Conditional Use District, with an underlying zoning district of CP  
(Article V)
  - Mixed Use/Conditional Use District (Article VI)
  - Planned Neighborhood District/Conditional Use District (Article VII)
  - Density Development/Conditional Use District, at the \_\_\_\_\_ Density  
(Article VIII)

APPLICATION FOR  
CONDITIONAL USE PERMIT

1. PROPOSED USE(S):

A. List the use(s) proposed for the Conditional Use Permit. (Use of the underlying district will be restricted only to the use(s) specified in this application.)

- Apparel and Accessory Sales
- Locksmith, Gunsmith
- Mini Warehousing (Self Storage Facility)
- Motor Vehicle Storage Yard
- Motor Vehicle Parts + Accessories
- Motor Vehicle Repair and/or Body Work
- Motor Vehicle Sales
- Office Use
- Photography Studio

B. Density: List the amount of acreage that will be residential, commercial, and/or open space, and the number of lots and/or dwelling units proposed, and the square footage of the non-residential units.

All Buildings will be commercial.  
Proposed 4000 sf Bldg  
Existing 608 sf Bldg

- Repair, Rental + Servicing
- Restaurant
- Retail or Servicing
- Second Hand Pawn + Flea Market
- Trades Contractor Activities
- Trailer Rentals
- Variety, Gift + Hobby Supply Sd
- Wholesale Sales

2. DIMENSIONAL REQUIREMENTS:

A. Reference either the dimensional requirements of the district, Sec. 1104 or list the proposed setbacks.

Front - 50  
Side - 30  
Rear - 30

B. Off-street parking and loading, Sec. 1202: List the number of spaces, type of surfacing material and any other pertinent information.

20 Proposed Parking Spaces  
Parking lot to be either grass or gravel

3. SIGN REQUIREMENTS:

Reference the district sign regulations proposed from Article XIII.

Sign contingent upon approval



4. LANDSCAPE AND BUFFER REQUIREMENTS:

- A. For all new non-residential and mixed use development abutting a public street, indicate the number and type of large or small ornamental trees used in the streetscape, yard space, and/or parking areas, plus the number and type of shrubs (Sec. 1102N). **NOTE: All required landscaping must be included on the site plan.**

34 Trees  
56 Shrubs

- B. Indicate the type of buffering and approximate location, width and setback from the property lines.

6' Landscape Buffer along all rights of way  
Fencing along rights of way

5. MISCELLANEOUS:

List any information not set forth above, such as the days and hours of the operation, number of employees, exterior lighting, noise, odor and smoke, emission controls, etc.

Operating Times 6 days a week Monday-Saturday 8am - 6pm

2-3 Employees

Exterior Lights on Flag, Entrance + Property

No extra noise, odor, smoke, emissions, etc

6. SITE PLAN REQUIREMENTS:

The application shall include a site plan drawn to the specifications of Sec. 1402. If the proposed uses involve development subject to the County Subdivision Ordinance, the site plan required may be general in nature, showing a generalized street pattern, if applicable, and the location of proposed uses. If the proposed uses include development not subject to the Subdivision Ordinance, the site plan shall be of sufficient detail to allow the Planning and Inspections Staff and the Planning Board to analyze the proposed uses and arrangement of uses on the site. It shall also include the footprints of all buildings (proposed and existing), the proposed number of stories, location and number of off-street parking and loading spaces, proposed points of access to existing streets and internal circulation patterns. In addition, the location of all proposed buffers and fences and landscaping shall be included on the site plan.

Attached

7. ACKNOWLEDGEMENT:

It is understood by the undersigned that the official zoning map, as originally adopted and subsequently amended, is presumed to be appropriate to the property involved and that the burden of proof for a zoning amendment (change) rests with the petitioner.

It is the responsibility of the petitioner (personally or by agent) to submit to the Planning and Inspections Department a valid request, not incompatible with existing neighborhood zoning patterns.

In order for the Planning Board to offer a favorable recommendation, and for the Board of Commissioners to approve, any Conditional Use District and Permit they must find from the evidence presented at their respective public hearing that:

- A. The use will not materially endanger the public health or safety if located according to the plan submitted and recommended;
- B. The use meets all required conditions and specifications;
- C. The use will maintain or enhance the value of adjoining or abutting properties, or that the use is a public necessity; and
- D. The location and character of the use, if developed according to the plan as submitted and recommended, will be in harmony with the area in which it is to be located and in general conformity with Cumberland County's most recent Comprehensive Land Use Plan and adopted planning policies.

I further understand I must voluntarily agree to all conditions proposed for the Conditional Use Permit.

The undersigned hereby acknowledge that the Planning and Inspections Staff has conferred with the petitioner or assigns, and the application as submitted is accurate and correct.

John Dawson Graham Columbia Otelia Green  
NAME OF OWNERS (PRINT OR TYPE)

40 Graham Ave Lake Waccamow NC 28450  
ADDRESS OF OWNER(S)

910-646-4514  
HOME TELEPHONE #

910-840-9180 840-5412  
WORK TELEPHONE #

John Dawson Graham  
SIGNATURE OF OWNER(S)

Columbia Otelia Green  
SIGNATURE OF OWNER(S)

The undersigned understands that the official zoning map, as originally adopted and subsequently amended, is presumed to be appropriate to the property involved and that the burden of proof for a zoning amendment (change) rests with the petitioner.

The undersigned hereby acknowledge that the Planning and Inspections Staff has conferred with the petitioner or assigns, and the application as submitted is accurate and correct.

John Dawson Graham  
NAME OF OWNERS (PRINT OR TYPE)

40 Graham Ave Lake Waccamaw, NC 28450  
ADDRESS OF OWNER(S)

HOME TELEPHONE #

WORK TELEPHONE #

Rev. Michael N. Nelson

NAME OF AGENT, ATTORNEY, APPLICANT (PRINT OR TYPE)

~~P.O. Box~~ 4100 Grandford, Fayetteville NC 28306  
ADDRESS OF AGENT, ATTORNEY, APPLICANT

HM 910-948-3388  
Cell # 910-850-9138

HOME TELEPHONE #

WORK TELEPHONE #



SIGNATURE OF OWNER(S)



SIGNATURE OF AGENT, ATTORNEY OR APPLICANT

484-6432 (c)

257-5766 (c)

SIGNATURE OF OWNER(S)

Mike Adams  
Surveyor  
w/ MAPS  
INC.

The contents of this application, upon submission, becomes "public record."

Michael J. Adams

NAME OF AGENT, ATTORNEY, APPLICANT (by assign) (PRINT OR TYPE)

1306 Fort Bragg Road Fay, NC 28305

ADDRESS OF AGENT, ATTORNEY, APPLICANT

257-5766

HOME TELEPHONE #

484-6432

WORK TELEPHONE #

  
SIGNATURE OF AGENT, ATTORNEY  
OR APPLICANT

- \* **ALL** record property owners must sign this petition.
- \* The contents of this application, upon submission, becomes "public record."

CUMBERLAND COUNTY ZONING ORDINANCE  
FEE SCHEDULE

REQUESTED ZONING DISTRICTS <sup>1</sup>	LESS THAN 5 ACRES	5 TO 50 ACRES	50 TO 100 ACRES	100+ ACRES
CONDITIONAL USE DISTRICTS <sup>2</sup> RESIDENTIAL DD/CUD	\$500	\$500	\$500	\$500
CONDITIONAL USE DISTRICTS <sup>2</sup> NONRESIDENTIAL PND/CUD MXD/CUD	\$700	\$800	\$800	\$800

- 1 If more than one zoning district is requested in the same application, the highest fee for the district requested will apply.
- 2 If a general rezoning is requested and based on recommendations of the Planning Board or County Commissioners, the applicant desires to submit a Conditional Use District and Permit application, the original application fee will be credited towards the Conditional Use District and Permit application fee.

**MOTIONS ON CONDITIONAL USE DISTRICT REZONING APPLICATIONS**

**IF TO APPROVE CONDITIONAL USE DISTRICT:**

I MOVE THAT THE BOARD OF COMMISSIONERS FINDS THAT THIS CONDITIONAL USE DISTRICT APPLICATION IS REASONABLE, NEITHER ARBITRARY NOR UNDULY DISCRIMINATORY, AND IN THE PUBLIC INTEREST, AND THAT THE CONDITIONAL USE(S) BE APPROVED OR DELETED AS DESCRIBED IN THE STAFF AGENDA MEMORANDUM:

---

**IF TO DENY CONDITIONAL USE DISTRICT:**

I MOVE THAT THE BOARD OF COMMISSIONERS FAILS TO FIND THAT THIS CONDITIONAL USE DISTRICT APPLICATION IS REASONABLE, NEITHER ARBITRARY NOR UNDULY DISCRIMINATORY, AND IN THE PUBLIC INTEREST, AND THAT IT THEREFORE BE DENIED.

**[\*\*\*\*IF CONDITIONAL USE DISTRICT IS DENIED, DO NOT MAKE ANY MOTION ON CONDITIONAL USE PERMIT].**

**IF TO APPROVE CONDITIONAL USE PERMIT:**

I MOVE THAT THE BOARD OF COMMISSIONERS FINDS THAT THIS CONDITIONAL USE PERMIT APPLICATION, IF COMPLETED AS PROPOSED AND SUBJECT TO THE CONDITIONS RECOMMENDED BY THE PLANNING BOARD:

- (I) WILL NOT MATERIALLY ENDANGER THE PUBLIC HEALTH AND SAFETY, AND
- (II) WILL NOT SUBSTANTIALLY INJURE THE VALUE OF ADJOINING OR ABUTTING PROPERTY, AND
- (III) WILL BE IN HARMONY WITH THE AREA IN WHICH IT IS TO BE LOCATED, AND
- (IV) WILL BE IN CONFORMITY WITH THE LAND USE PLAN, THOROUGHFARE PLAN OR OTHER PLAN OFFICIALLY ADOPTED BY THE BOARD OF COMMISSIONERS.

October 22, 2007



ITEM NO. 4

## COUNTY of CUMBERLAND

James E. Martin  
County Manager

Cliff Spiller  
Assistant County Manager

Juanita Pilgrim  
Deputy County Manager

Office of the County Manager

Amy H. Cannon  
Assistant County Manager

### MEMORANDUM FOR BOARD OF COMMISSIONERS AGENDA OF NOVEMBER 17, 2008

**TO:** BOARD OF COUNTY COMMISSIONERS

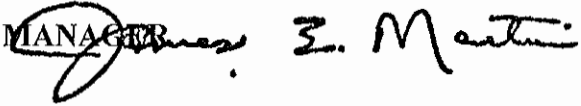
**FROM:** JAMES E. MARTIN, COUNTY MANAGER 

**DATE:** NOVEMBER 12, 2008

**SUBJECT:** CONSIDERATION OF CUMBERLAND COUNTY FINANCE COMMITTEE REPORT AND RECOMMENDATIONS

### BACKGROUND

The Finance Committee had a special meeting on November 12, 2008. Management will make a full presentation to the Board of Commissioners at the November 17, 2008 meeting.

The action of the Finance Committee was to ratify the Manager's proposed responses to address the current economic circumstances.

/ct

CM111208-1



**\*\* EXPENDITURES \*\***

	FY2006			FY2007			FY2008			Adopted Budget	FY2009 Actual 11/7/08	Budget 11/7/08	Percent Spent
	Total Obligations	Final Budget	Percent Spent	Total Obligations	Final Budget	Percent Spent	Total Obligations	Final Budget	Percent Spent				
Personal Services	81,665,989	84,487,297	96.66	87,566,527	90,903,212	96.33	93,218,363	95,531,211	97.58	100,268,001	30,936,341	100,461,506	30.794
Operating Expenditures	20,398,520	22,050,344	92.51	20,913,689	22,987,986	90.98	21,647,692	23,351,129	92.71	21,643,021	12,928,790	23,035,843	56.125
Other Charges and Services	114,594,499	116,419,007	98.43	118,150,271	119,736,440	98.68	122,649,463	125,284,687	97.90	117,850,389	89,663,149	120,178,546	74.608
<b>Subtotal</b>	<b>216,659,008</b>	<b>222,956,648</b>	<b>97.18</b>	<b>226,630,487</b>	<b>233,627,638</b>	<b>97.00</b>	<b>237,515,519</b>	<b>244,167,027</b>	<b>97.28</b>	<b>239,761,411</b>	<b>133,528,280</b>	<b>243,675,895</b>	<b>54.797</b>
Capital Outlay	11,861,945	15,377,760	77.14	11,504,295	11,851,706	97.07	9,777,418	9,949,215	98.27	1,648,899	1,118,545	6,503,050	17.200
Transfers	13,135,607	13,609,680	96.52	9,294,891	9,849,186	94.37	10,402,066	11,126,219	93.49	7,330,703	24,371	7,848,564	0.311
Debt Service	23,865,835	23,865,839	100.00	24,491,218	24,491,222	100.00	24,209,586	24,209,592	100.00	27,294,949	1,552,058	27,294,949	5.686
<b>Total Expenditures</b>	<b>265,522,395</b>	<b>275,809,927</b>	<b>96.27</b>	<b>271,920,890</b>	<b>279,819,752</b>	<b>97.18</b>	<b>281,904,588</b>	<b>289,452,053</b>	<b>97.39</b>	<b>276,035,962</b>	<b>136,223,254</b>	<b>285,322,458</b>	<b>47.74</b>



## REVENUE

- Ad valorem taxes- real & personal
  - Over the last three years, the % collected of budget has decreased from 103.51% to 101.07% (2.44%)
    - this equates to \$3 million that did not roll into fund balance
- Ad valorem taxes - motor vehicles
  - Over the last three years, the % of budget has decreased from 119.37% to 102.45% (16.92%)
    - This equates to \$2.3 million that did not roll into fund balance
- Ad valorem
  - Tax collection rate has increased from 98.34% to 99.13% (0.79%)
    - Results in lower prior year collections
    - Prior year's collections reduced from \$7.02 million to \$5.99 million
  - Overall, % collected as a percentage of budget has dropped from 105.29% to 101.11% (4.18%)
    - This equates to a net \$6.03 million that did not roll into fund balance
- Sales taxes
  - Sales tax collections are difficult to accurately project due to their volatility and the effects of annexations
  - FY2009 sales taxes were budgeted 4% less than actual FY2008
  - Beer & wine & sales taxes on video and telecommunications are budgeted lower than actual FY2008 collections
- Intergovernmental revenue
  - Consists primarily of state and federal revenue
    - State departments and divisions instructed by Governor to reduce budgets 3%
    - May result in a trickle down to local governments and necessitate a reduction in services
- Licenses and permits
  - Register of Deeds fees have declined \$270,553 (12.6%) since FY2006
    - FY2009 was budgeted at a 16.4% reduction from FY2008 actual collections
  - Inspection fees have declined \$580,731 (39.4%) since FY2006
    - FY2009 is budgeted \$265,498 less than actual FY2008 and \$591,660 less than FY2008 budget
- Sales & services
  - Fees are budgeted slightly above the FY2006-08 average (\$84,650 increase)
    - FY2008 collections were high compared to FY2006 & FY2007.
    - FY2009 budget more inline with FY2006 & FY2007

- Miscellaneous
  - Interest income experienced a \$1,240,101 decline from FY2007
    - FY2009 budget amount is \$542,729 below actual FY2008
    - Reflects not only the current financial environment but the reality that we are spending down available fund balance from prior years
  - Received \$1.0 million CFVMC balloon payment in FY2008
- Overall, we should realize our revenue budget in spite of the current economic climate.
  - However, just meeting budget projections will seriously affect our ability to appropriate fund balance.
  - Since FY2002, we have been able to appropriate 3% of fund balance because of our conservative approach to budgeting.
  - As actual collections as a percentage of budget declines, that difference must be accounted for by reducing spending or finding a new source of revenue.
  - Our ability to fund one-time expenditures for departments and major capital projects will be affected

#### EXPENDITURES

- Percent of the budget obligated has increased 1.12% since FY2006
  - Represents \$3.2 million not rolling into fund balance

**Cumberland County  
Proposed Expenditure Reductions**

- 1 Delay hiring for 120 days from pay out unless there will be an undue impact on County operations, **then re-evaluate position after 120 days**
  - a Prohibit/restrict use of overtime
  - b Encourage the use of comp time versus paid overtime where practical
- 2 Discontinue budgeting departmental unrecognized discretionary revenue
- 3 Delay transfers from General Fund to year-end where feasible
- 4 Accelerate transfers to General Fund when practical
- 5 Restrict the use of fund balance for new initiatives
- 6 Delay transfer of savings from Foster Care rate change to Water & Sewer Fund
- 7 Freeze or reduce the number of vehicles purchased
- 8 Reduce/restrict travel especially out-of-state
- 9 Reduce supplies
  - a Freeze furniture and equipment purchases to include computers
- 10 Explore opportunities for 4-day work week



ITEM NO. 5

## COUNTY of CUMBERLAND

James E. Martin  
County Manager

Cliff Spiller  
Assistant County Manager

Juanita Pilgrim  
Deputy County Manager

*Office of the County Manager*

Amy H. Cannon  
Assistant County Manager

### MEMORANDUM FOR BOARD OF COMMISSIONERS AGENDA OF NOVEMBER 17, 2008

**TO: BOARD OF COUNTY COMMISSIONERS**

**FROM: JAMES E. MARTIN, COUNTY MANAGER**

**DATE: OCTOBER 31, 2008**

**SUBJECT: REPORT ON PARKS AND RECREATION BOND REFERENDUM  
AND FUNDING OPTIONS**

#### BACKGROUND

At the June 16, 2008 meeting, management was directed to report back in November regarding a Parks and Recreation Bond issue and options for funding.

City and County Staff have met to consider these matters and our consensus is that the timing and current economic conditions are not right for a bond referendum for the foreseeable future. Funding options are attached for funding "Joint Projects".

Further, County staff believes there is a need for a unified method of funding both the County and City Parks and Recreation operations in order to facilitate a true consolidation of operations.

Currently, the City operates the County recreation district separate from the City system. This is due to dedicated funding from the Parks and Recreation Tax District for the County program and the need to account for these funds separately from City funds. This would advance a goal and need that was recognized in the contractual framework at the time of consolidating County Parks and Recreation with the City.

#### RECOMMENDATION / PROPOSED ACTION

Consider authorizing management to pursue with City Management, the development of a funding model that would not increase the current tax rate of the City or County, but perhaps would create a unified funding method.

Attachment

/ct

CM103108-1

**Parks and Recreation  
Funding Options for "Joint Projects"  
October 30, 2008**

**Proposed Attributes of a "Joint Project"**

- Located within Fayetteville or an unincorporated area of Cumberland County
- Available to all citizens of Cumberland County, or is designed for a group of citizens within Cumberland County such as senior citizens or individuals with disabilities
- Unique in character that will attract residents and visitors from all areas of Cumberland County
- Both entities consider the project a high priority and are willing to jointly fund the project

**50/50 Basis**

- City and County split the cost for joint projects 50/50
- Proposed by Parks & Recreation Advisory Board
- Observation:
  - The 50/50 basis would share the cost equally between the entities; however, City residents would pay more than their fair share if the County's share would be paid out of the County-wide general tax rate.
  - If the County's share would be paid out of the P&R district, those County residents would pay more than their fair share due to the population/tax base in the district vs. the population/tax base in the City.

**Location Basis**

- Location of the facility determines which entity pays
  - City pays 100% if located within the City
  - County District pays 100% if located within the County District
- Observation:
  - Does this method really spread the cost to those residents that would use the facilities?
  - For example, if a regional sports field is constructed in the City for the purpose of providing fields for teams located throughout the County, is it appropriate for only City residents to pay for the facility?

### Population Basis

- City and District share in the cost of joint projects based on their relative share of total population
- Observation: Recommend City population exclude Fort Bragg residents since no property tax revenues come from residents living on the base.

### Taxable Property Valuation Basis

- City and District share in the cost of joint projects based on their relative share of taxable property values

### County-Wide Basis

- County pays 100% of the cost of joint projects.
- Observation:
  - Can hold a bond referendum
  - If projects benefit everyone in Cumberland County, including its municipalities, then all residents contribute an equitable share.

J. BREEDEN BLACKWELL  
Chairman

JEANNETTE M. COUNCIL  
Vice Chairman

KENNETH S. EDGE  
JOHN T. HENLEY, JR.  
BILLY R. KING  
EDWARD G. MELVIN  
DIANE WHEATLEY



MARSHA S. FOGLE  
Clerk to the Board

MARIE COLGAN  
Deputy Clerk

**BOARD OF COMMISSIONERS**

5th Floor, New Courthouse • P.O. Box 1829 • Fayetteville, North Carolina 28302-1829  
(910) 678-7771 • Fax: (910) 678-7770

ITEM NO. 6A

November 10, 2008

**November 17, 2008 Agenda Item**

TO: Board of Commissioners  
FROM: Marie Colgan, Deputy Clerk *MC*  
SUBJECT: Adult Care Home Community Advisory Committee

The Adult Care Home Community Advisory Committee has the following vacancies:

Rev. Nanette Tomlinson-Knoell has resigned due to health reasons. Dr. Claudett Tompkins is being replaced due to absences (see attached).

I have attached the current membership and applicant list for this board.

**PROPOSED ACTION: Make nomination to fill the two (2) vacancies.**

Attachments

pc: Andrea Wright-Valdez  
Mid-Carolina Area Agency on Aging

*Celebrating Our Past... Embracing Our Future*

**Marie Colgan**

---

**From:** Andrea Valdez [andrea@mccog.org]  
**Sent:** Monday, November 10, 2008 4:41 PM  
**To:** Marie Colgan  
**Subject:** Adult Care Home Committee

Marie,

Looking through my records, Ms. Claudette Tompkins' last documented activity with the Cumberland Co. Adult Care Home Committee was March 2004. She has not attended any CAC Quarterly Meetings for the years 2007 or 2008. I would like to request she be replaced on the Committee along with Ms. Nanette Knoll-Tomlinson (who resigned for health reasons)

Thanks,  
Andrea Valdez



ADULT CARE HOME COMMUNITY ADVISORY COMMITTEE  
Initial Appointment 1 Year/Subsequent Term 3 Years

<u>Name/Address</u>	<u>Date Appointed</u>	<u>Term</u>	<u>Expires</u>	<u>Eligible For Reappointment</u>
Marian J. Hackett (B /F) 4184 Ferncreek Drive Fayetteville, NC 28314 323-3060/672-2129	4/08	Initial	Apr/09 4/30/09	Yes
Toney Edwards (B/M) 3622 Clearwater Drive Fayetteville, NC 28311 822-4261/864-6262	04/08	Initial	Apr/09 4/30/09	Yes
Mary Ann Brown-Jackson 1959B James Hamner Way Fayetteville, NC 28311 822-1311/893-8151 x330 (W)	1/06	1 <sup>st</sup>	Jan/09 1/31/09	Yes
Rev. Nanette Tomlinson-Knoell (W/F) 609 Tallstone Drive Fayetteville, NC 28311 339-2201/489-2198(W)	02/08	Initial	Feb/09 2/28/09	Yes
Herma Jean Bradley ( /F) 714 Topeka Street Fayetteville, NC 28301 822-3689	6/06	1 <sup>st</sup>	June/09 6/30/09	Yes
Mexie Fields ( /F) 1815 Primrose Drive Fayetteville, NC 28301 488-8432	1/06	1 <sup>st</sup>	Jan/10 1/31/10	Yes
Yvonne Booth (B/F) 4568 Turquoise Road Fayetteville, NC 28311 488-7260	8/08	Initial	Aug/09 8/31/09	Yes
Brenda Douglas (B/F) 6109 Garden Court Fayetteville, NC 28311 717/0123/677-2965 (W)	5/08	Initial	May/09 5/31/09	Yes

Adult Care Home Community Advisory Committee, page 2

<u>Name/Address</u>	<u>Date Appointed</u>	<u>Term</u>	<u>Expires</u>	<u>Eligible For Reappointment</u>
Dell Caramanno (W/F) 5578 Quietwood Place Fayetteville, NC 28304 423-2622	4/08	Initial	Apr/09 4/30/09	Yes
Stephanie Hodges (W/F) 3424 Harrisburg Road Fayetteville, NC 28306 429-9300/584-0358 (C)	10/06	1 <sup>st</sup>	Nov/09 11/30/09	Yes
Wynella A. Myers (B/F) 706 Sarazan Drive Fayetteville, NC 28303 822-5526/273-8483 (C)	8/07	1 <sup>st</sup>	Aug/10 8/31/10	Yes
Janet Pelley 18 Adams Street Ft. Bragg, NC 28307 497-4947	4/06	2 <sup>nd</sup>	April/09 4/30/09	No
John Poulos (W/M) 3025 Brechin Road Fayetteville, NC 28303 867-2622/424-4242(W)	6/06	2 <sup>nd</sup>	June/09 6/30/09	No
Teresa R. McNeill (B/F) 3518 Pickerel Street Fayetteville, NC 28306 480-0313/483-3648, Ext. 1109 (W)	2/08	1 <sup>st</sup>	Feb/11 2/28/11	Yes
Dr. Claudett Tompkins (B/F) 260 Old Farm Road Fayetteville, NC 28314 864-5336/424-4797(W)	9/06	2 <sup>nd</sup>	Aug/09 8/31/09	No
Kim Howard (W/F) 6018 Lakaway Drive Fayetteville, NC 28306 308-5974	4/08	1 <sup>st</sup>	Apr/11 4/30/11	Yes

CONTACT: Andrea Wright-Valdez, Regional Ombudsman, Mid-Carolina Area Agency on Aging,  
P. O. Box 1510, Fayetteville, NC 28302. Phone: 323-4191, x 25, fax # 323-9330  
MEETINGS: Quarterly: March, June, September, December 3<sup>rd</sup> Thursday of Particular Month,  
10:00 AM, Blue Street Senior Center

APPLICANTS FOR  
ADULT CARE HOME COMMUNITY ADVISORY COMMITTEE

<u>NAME/ADDRESS/TELEPHONE</u>	<u>OCCUPATION</u>	<u>EDUCATIONAL BACKGROUND</u>
EBRON, SANDRA (B/F) PO BOX 65306 FAYETTEVILLE, NC 28306 424-3932/(919) 922-9446 (C)	UTILIZATION MGT SPECIALIST MENTAL HEALTH – LUMBERTON	MASTERS – SOCIAL WORK
HAIRE, CASSANDRA W. (B/F) 515 ALBANY STREET FAYETTEVILLE, NC 28301 728-0175	SELF EMPLOYED	PURSUING MBA

J. BREEDEN BLACKWELL  
Chairman

JEANNETTE M. COUNCIL  
Vice Chairman

KENNETH S. EDGE  
JOHN T. HENLEY, JR.  
BILLY R. KING  
EDWARD G. MELVIN  
DIANE WHEATLEY



MARSHA S. FOGLE  
Clerk to the Board

MARIE COLGAN  
Deputy Clerk

**BOARD OF COMMISSIONERS**

5th Floor, New Courthouse • P.O. Box 1829 • Fayetteville, North Carolina 28302-1829  
(910) 678-7771 • Fax: (910) 678-7770

November 7, 2008

ITEM NO. 6B

**November 17, 2008 Agenda Item**

TO: Board of Commissioners  
FROM: Marie Colgan, Deputy Clerk *MC*  
SUBJECT: Board of Health

The Board of Health will have the following vacancies on December 31, 2008:

General Public Representatives:

**Cureton L. Johnson** will complete his first term and is eligible for reappointment.

Pharmacist:

**Tom Nicholson** will complete his first term and is eligible for reappointment.

Physician:

**Dr. Cynthia Norris** will complete her first term and is eligible for reappointment.

I have attached the current membership list and applicant list for this Board.

**PROPOSED ACTION:** Make nomination to fill the three (3) vacancies.

Attachments

pc: Wayne Raynor, Health Director

*Celebrating Our Past... Embracing Our Future*

BOARD OF HEALTH  
3 Year Term

<u>Name/Address</u>	<u>Date Appointed</u>	<u>Term</u>	<u>Expires</u>	<u>Eligible For Reappointment</u>
<u>Veterinarian</u>				
Dr. Ennis V. Williams (B/M) 4617 Bent Grass Drive Fayetteville, NC 28312 867-2248/578-1877(W)	01/07	1 <sup>st</sup>	Dec/09 12/31/09	No
	(already served a term as a General Public Rep)			
<u>Physician</u>				
Dr. Cynthia Norris (W/F) 6525 Windy Creek Way Fayetteville, NC 28306 429-3258/323-9111 (W)	06/07	1 <sup>st</sup>	Dec/08 12/31/08	Yes
	(filling unexpired term)			
<u>Dentist</u>				
Dr. Walter S. Scott, III (B/M) 686 Stockbridge Court Fayetteville, NC 28311 811-3543/323-3133(W)	01/07	1 <sup>st</sup>	Dec/09 12/31/09	Yes
<u>Registered Nurse</u>				
Kim S. McDonald (W/F) VA Medical Center 2300 Ramsey Street Fayetteville, NC 28311 822-9703/482-5262(W)	01/07	1 <sup>st</sup>	Dec/09 12/31/09	Yes
<u>Optometrist</u>				
Barbara Ciampa (W/F) 3006 Metthame Drive Fayetteville, NC 28306 648-0680/484-7139(W)	12/07	1 <sup>st</sup>	Dec/10 12/31/10	Yes
<u>Pharmacist</u>				
Tom Nicholson (W/M) 274 Saint Johns Wood Fayetteville, NC 28303 485-1059/609-6839	4/08	1 <sup>st</sup>	Dec/08 12/31/08	Yes
	filling unexpired term			
<u>Engineer</u>				
Jimmy Kizer (W/M) 214 Woodcrest Road Fayetteville, NC 28305 484-0508/484-5191(W)	12/07	1 <sup>st</sup>	Dec/10 12/31/10	Yes

<u>Name/Address</u>	<u>Date Appointed</u>	<u>Term</u>	<u>Expires</u>	<u>Eligible For Reappointment</u>
<u>General Public Reps.</u>				
Cureton L. Johnson (AA/M) 1909 Bellemeade Road Fayetteville, NC 28303 485-3025/483-6505(W)	12/05	1st	Dec/08 12/31/08	Yes
Barbara S. Marshall (B/F) 7640 Wilkins Drive Fayetteville, NC 28311 488-2615/977-2303 (W)	01/07	1 <sup>st</sup>	Dec/09 12/31/09	Yes
Carol E. Schaeffer (W/F) 1704 Cherokee Drive Fayetteville, NC 28303 223-3030/483-1437 (W)	01/07	1 <sup>st</sup>	Dec/09 12/31/09	Yes

COMMISSIONER LIAISON: John Henley

Contact: Wayne Raynor, Health Director  
Tracy Gurganus, Secretary  
Phone: 433-3721  
Fax: 433-3659

Meetings: 3rd Tuesday of the month 6:00 PM, Board Room, Health Department (July and August meetings take place only if desired)

APPLICANTS FOR  
BOARD OF HEALTH

<u>NAME/ADDRESS/TELEPHONE</u>	<u>OCCUPATION</u>	<u>EDUCATIONAL BACKGROUND</u>
BERRY-CABAN, CRISTOBAL S. (H/M) 5739-01 IVANHOE COURT FAYETTEVILLE, NC 28314 (813) 751-3004/907-8844	MEDICAL STATISTICIAN WOMACK ARMY MED. CTR.	PhD – URBAN SOCIAL INST. MA – HISTORY & POLITICAL SCIENCE; BA – HISTORY
HARRIS, GLENDA PURDIE (B/F) 1874 GOLA DRIVE FAYETTEVILLE, NC 28301 488-2434/630-3041	COMPLIANCE OFFICER MAGBY ASSOCIATES	MASTER OF SCIENCE IN ADMINISTRATION
JOHNSON, LONNIE EDWARD (AA/M) 5206 LANDMARK DRIVE FAYETTEVILLE, NC 28311 488-8372/224-4841 (C) <b>**SERVES ON THE ADULT CARE HOME COMMUNITY ADV. BOARD**</b>	TRUCK DRIVER DON'S TRUCKING	HIGH SCHOOL GRADUATE
KIZER, JIMMY (W/M) 214 WOODCREST ROAD FAYETTEVILLE, NC 28305 484-0508/484-5191 (W)	CIVIL ENGINEER	BS – CIVIL ENGINEERING
NORRIS, CYNTHIA M., MD (W/F) 6525 WINDY CREEK WAY FAYETTEVILLE, NC 28306 429-3258/323-9111 (W)	FAMILY PHYSICIAN	BS, MD
SMITH, AMANDA H. (W/F) 110 ALOHA DRIVE FAYETTEVILLE, NC 28311 308-3847/433-3702 (W)	CCMAP, PROGRAM COORDINATOR/ MANAGER CAPE FEAR VALLEY	PHARMACY TECHNICIAN BS – BUSINESS ADMIN.
SPAIN, PHYLLIS M. (B/F) PO BOX 821 SPRING LAKE, NC 28390 484-4726/916-4974(W)	MINISTER/CHAPLAIN	DOCTORATE OF MINISTRY CLINICAL PASTORAL ED.
	<b>**SERVES ON THE MENTAL HEALTH BOARD**</b>	

J. BREEDEN BLACKWELL  
Chairman

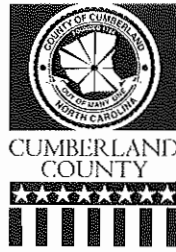

MARSHA S. FOGLE  
Clerk to the Board

JEANNETTE M. COUNCIL  
Vice Chairman

MARIE COLGAN  
Deputy Clerk

KENNETH S. EDGE  
JOHN T. HENLEY, JR.  
BILLY R. KING  
EDWARD G. MELVIN  
DIANE WHEATLEY

**BOARD OF COMMISSIONERS**

5th Floor, New Courthouse • P.O. Box 1829 • Fayetteville, North Carolina 28302-1829  
(910) 678-7771 • Fax: (910) 678-7770

ITEM NO. 6C

November 7, 2008

**November 17, 2008 Agenda Item**

TO: Board of Commissioners  
FROM: Marie Colgan, Deputy Clerk *MC*  
SUBJECT: Fayetteville Area Convention & Visitors Bureau

The Fayetteville Area Convention and Visitors Bureau will have the following vacancies on December 31, 2008:

Hotels/Motels Under 100 Rooms Representative:

Chintan Patel – will complete his first term and is eligible for reappointment. However, the FACVB has requested that he be moved into the below slot as his room numbers have increased. **Dan Roberts** with Wingate Inn has been recommended to fill this slot.

Hotels/Motels Over 100 Rooms Representative:

Cameron Stout - is no longer an owner and the FACVB has recommended that **Chintan Patel** fill this vacancy.

I have attached the current membership list and applicant list for this Board.

**PROPOSED ACTION: Make nominations to fill the two (2) vacancies.**

pc: John Meroski, FACVB

*Celebrating Our Past...Embracing Our Future*



FAYETTEVILLE AREA CONVENTION AND VISITORS BUREAU  
BOARD OF DIRECTORS  
3 Year Terms

<u>Name/Address</u>	<u>Date Appointed</u>	<u>Term</u>	<u>Expires</u>	<u>Eligible For Reappointment</u>
<u>Hotel/Motels under 100 rooms Representatives:</u>				
Chintan Patel (I/M)	08/06	1 <sup>st</sup>	Dec/08	Yes
Knight's Inn 2848 Bragg Boulevard Fayetteville, NC 28303 485-4163/978-8504(W)	(to fill unexpired term)		12/31/08	
John Keefe (W/M)	12/07	2 <sup>nd</sup>	Dec/10	No
5833 Woodhaven Circle Fayetteville, NC 28311 488-4165/309-6542(W)			12/31/10	
<u>Hotel/Motel over 100 rooms Representatives:</u>				
Cameron Stout (W/M)	01/06	1st	Dec/08	Yes
1131 Longleaf Drive Fayetteville, NC 28305 323-5515/484-2662(W)/323-0111(Holiday Inn)			12/31/08	
Charles R. Wellons, II (W/M)	12/07	2 <sup>nd</sup>	Dec/10	No
174 Ellerslie Fayetteville, NC 28303 864-4893/436-3131(W)			12/31/10	
<u>At Large</u>				
John Mitchell (B/M)	8/06	2nd	June/09	No
5901 Panelway Place Fayetteville, NC 28304 424-8381/624-2591(cell)			6/30/09	

Representative, Hotel/Motel with meeting space in excess of 6,000 square feet

Board of Directors Appointee:

Vacant

<u>Name/Address</u>	<u>Date Appointed</u>	<u>Term</u>	<u>Expires</u>	<u>Eligible For Reappointment</u>
---------------------	---------------------------	-------------	----------------	---------------------------------------

Hotel/Motel Representative

Board of Directors Appointee:

Subodh Thakur 7/97

Villager Lodge and Shangri La Motel

521 Ramsey Street

Fayetteville, NC 28301-4911

483-2621(W)

Chamber of Commerce Representative:

Henry Holt

Holt Oil

P. O. Box 53157

Fayetteville, NC 28303

Commissioner Liaison – Commissioner Diane Wheatley

Ex-officio Members:

James Martin, County Manager

Rick Reno, CEO, Coliseum Complex Manager

Dale Iman, City Manager

Contact: John Meroski (or Tammy Johnson), Fayetteville Area Convention & Visitors' Bureau – 483-5311

Meetings: Second Thursday of every other month (starting in January) at 12:00 pm – Wellington's @ Holiday Inn - Bordeaux.

APPLICANTS FOR  
FAYETTEVILLE AREA CONVENTION AND VISITORS BUREAU  
BOARD OF TRUSTEES

<u>NAME/ADDRESS/TELEPHONE</u>	<u>OCCUPATION</u>	<u>EDUCATIONAL BACKGROUND</u>
ANDREWS-McCALL, MAXINE (B/F) 5637 MUM CREEK LANE FAYETTEVILLE, NC 28304 423-1727/322-5800 (C)	RETIRED	DOCTORATE IN EDUC. ADMINISTRATION
HAIRE, CASSANDRA W. (B/F) 515 ALBANY STREET FAYETTEVILLE, NC 28301 728-0175	SELF EMPLOYED	PURSUING MBA
HOGAN, GEORGE (B/M) 2641 ADAMS LAKE ROAD, APT A FAYETTEVILLE, NC 28304 339-0536	RETIRED: ARMY & EDUCATION	Ph.D – EDUCATION MA – HE ADMINISTRATION BA – SOCIAL SCIENCE
HOLLOMAN, GWEN (B/F) 721 EDGEHILL ROAD FAYETTEVILLE, NC 28314 868-1691/822-7968 (W) **SERVES ON THE WORKFORCE DEVELOPMENT BOARD**	HIGH PERFORMANCE DEVELOPMENT COORD. VA HOSPITAL	RHIA/M.Ed
O'DONNELL, DAWN 2072 BIRCHCREFT DRIVE FAYETTEVILLE, NC 28304 425-3619/916-1207 (W)	RETIRED ARMY TAX PREPARER -H&R BLOCK	AA – ACCOUNTING
SALLEY, LUKE (B/M) 104 UNIVERSITY AVENUE FAYETTEVILLE, NC 28301 364-8505/483-0121 (W)	RETIRED CORRECTIONAL CAPTAIN FIRST PRESBY. CHURCH	BA – ECONOMICS & ACCOUNTING
TALLY, WILLIAM LOCKETT (W/M) 414 VISTA DRIVE FAYETTEVILLE, NC 28305 489-3533/483-4175	ATTORNEY TALLY & TALLY	BA-POLITICAL SCIENCE JD-SCHOOL OF LAW

J. BREEDEN BLACKWELL  
Chairman

JEANNETTE M. COUNCIL  
Vice Chairman

KENNETH S. EDGE  
JOHN T. HENLEY, JR.  
BILLY R. KING  
EDWARD G. MELVIN  
DIANE WHEATLEY



MARSHA S. FOGLE  
Clerk to the Board

MARIE COLGAN  
Deputy Clerk

**BOARD OF COMMISSIONERS**

5th Floor, New Courthouse • P.O. Box 1829 • Fayetteville, North Carolina 28302-1829  
(910) 678-7771 • Fax: (910) 678-7770

November 7, 2008

ITEM NO. 6D

**November 17, 2008 Agenda Item**

TO: Board of Commissioners  
FROM: Marie Colgan, Deputy Clerk *Mc*  
SUBJECT: Human Relations Commission Vacancy

The Human Relations Commission has the following vacancies:

Jose Yopez was appointed on October 6 to fill a vacant position. Mr. Yopez has not responded to our letter regarding his appointment and all contact information available is not longer correct. The liaison for the Human Relations Commission has agreed that another appointment is in order.

I have attached the current County membership list and applicant list for this commission.

**PROPOSED ACTION:** Make nomination to fill the vacancy.

pc: Ron McElrath - Human Relations Director

*Celebrating Our Past...Embracing Our Future*

HUMAN RELATIONS COMMISSION  
 (County Commissioner Appointees)  
 2Year Term

Name/Address	Date Appointed	Term	Expires	Eligible for Reappointment
Cornelius Williams (B/M) 1327 Four Wood Drive Fayetteville, NC 28312 484-5044	11/06	1 <sup>st</sup>	Nov/09 11/01/09	Yes
Zeandrew Farrow 403 Virginia Avenue Spring Lake, NC 28390 257-8570 (Cell)	10/06	2 <sup>nd</sup>	Nov/08 11/01/08	No
Lynette Hill Gardner (B/F) 1530 Rosebud Drive Fayetteville, NC 28311 488-6098/822-9963(W)	6/07	2 <sup>nd</sup>	July/09 07/01/09	No
Denise Giles(W/F) 1062 Center Street Fayetteville, NC 28306 485-8079/826-2454, ext.22(W)	6/07	2 <sup>nd</sup>	July/09 07/01/09	No

Contact: Ronald McElrath – 433-1605 – Fax # 433-1535  
 Human Relations Director  
 City of Fayetteville

Meetings: 2<sup>nd</sup> Thursday of every month – 5:30 pm  
 City Hall – Lafayette Room

APPLICANTS FOR  
HUMAN RELATIONS COMMISSION

<u>NAME/ADDRESS/PHONE</u>	<u>OCCUPATION</u>	<u>EDUCATIONAL BACKGROUND</u>
BRIGGS, BENITA Y. (B/F) 1116 BINGHAM DRIVE FAYETTEVILLE, NC 28304 822-1154/672-1294 (W) <b>**SERVES ON THE ADULT CARE HOME ADVISORY BOARD**</b>	OFFICE ASSISTANT IV FSU	BA IN HISTORY; 08 GRAD – BA IN SOCIOLOGY
CHISOLM, ALICIA S. (AA/F) 1855 CASCADE STREET FAYETTEVILLE, NC 28301 488-7820/488-5935 (W) <b>**SERVES ON THE CIVIC CENTER COMMISSION**</b>	SELF EMPLOYED RETIRED DOA CIVILIAN	MBA & BS – BUSINESS ADMIN/MGT
FLEMING JR., DR REV JOE (B/M) 7235 RYAN STREET FAYETTEVILLE, NC 28304 339-5648	CHURCH PASTOR CHURCH OF GOD	SOME COLLEGE
GABRIEL, GRANT (W/M) 3690 RAEBURN COURT FAYETTEVILLE, NC 28314 678-8995/907-0203 (W)	EDUCATOR ADMINISTRATOR FT. BRAGG SCHOOLS	BS, MS, M. ED, ED. D
HALL, BARBARA M. (W/F) 1305 SKYLINE DRIVE FAYETTEVILLE, NC 28314 495-0603/483-8970 (W)	EXECUTIVE DIRECTOR OF CONTACT CRISIS HELPLINE	BA – SOCIOLOGY (2007) MS IN HUMAN SVS
MACK, DAVID J. (B/M) 5479 LYNBROOK COURT FAYETTEVILLE, NC 28314 867-1214 <b>**SERVES ON THE EQUALIZATION &amp; REVIEW BOARD**</b>	RETIRED	MASTERS – ED.
McLEAN, ALICIA RENEE (B/F) 5058 SUMMER RIDGE DRIVE FAYETTEVILLE, NC 28303 487-0390/323-5288 (W) <b>**SERVES ON WORKFORCE DEVELOPMENT BOARD**</b>	DIALYSIS TECHNICIAN FAY. KIDNEY CENTER	BS – PSYCHOLOGY
McNEILL, ELVIN (B/M) 2280 SPINDLETREE DRIVE FAYETTEVILLE, NC 28304 423-7027/677-2552	SOCIAL WORKER DSS	BS – MATH
POPE, RITA J. (B/F) 679 BARTON'S LAND PL #4 FAYETTEVILLE, NC 28314 864-4993	RETIRED CC JAILER	SOME COLLEGE
SKINNER-COLEMAN, ANNETTE (O/F) 916 BRAMBLEWOOD COURT FAYETTEVILLE, NC 28314 869-7949/907-0209 (W)	GUIDANCE COUNSELOR FT BRAGG SCHOOLS	MA – SPECIAL EDUC. BA – SOCIOLOGY

<u>NAME/ADDRESS/PHONE</u>	<u>OCCUPATION</u>	<u>EDUCATIONAL BACKGROUND</u>
WARREN, JOHNETTA (B/F) 411 HALCYON CIRCLE FAYETTEVILLE, NC 28306 868-4002/261-3735 (C)	WORK FIRST PROGRAM	GED

J. BREEDEN BLACKWELL  
Chairman

JEANNETTE M. COUNCIL  
Vice Chairman

KENNETH S. EDGE  
JOHN T. HENLEY, JR.  
BILLY R. KING  
EDWARD G. MELVIN  
DIANE WHEATLEY



MARSHA S. FOGLE  
Clerk to the Board

MARIE COLGAN  
Deputy Clerk

**BOARD OF COMMISSIONERS**

5th Floor, New Courthouse • P.O. Box 1829 • Fayetteville, North Carolina 28302-1829  
(910) 678-7771 • Fax: (910) 678-7770

November 12, 2008

ITEM NO. 6E

**November 17, 2008 Agenda Item**

TO: Board of Commissioners  
FROM: Marie Colgan, Deputy Clerk *MC*  
SUBJECT: Mental Health Board

The Mental Health Board will have the following vacancies on December 31, 2008:

Mental Health Rep from a Citizens Organization or Primary Consumer:  
**Luis Collazo** will complete his first term and is eligible for reappointment.

Professional Rep (Psychology, Social Work, Nursing, Religion):  
**Rev. Floyd Johnson, Jr.** will complete his first term and is eligible for reappointment.

I have attached the current membership and applicant lists for this board.

**PROPOSED ACTION:** Make nominations to fill the two (2) vacancies.

Attachments

pc: Hank Debnam, Mental Health Director

*Celebrating Our Past... Embracing Our Future*



MENTAL HEALTH BOARD

8/08

(Cumberland County Area Mental Health, Developmental Disabilities and Substance Abuse Board)

4 Year Term (for current members as of 6-06)

3 Year Term (for members appointed after 6-06)

<u>Name/Address</u>	<u>Date Appointed</u>	<u>Term</u>	<u>Expires</u>	<u>Eligible For Reappointment</u>
<u>Licensed Physician</u>				
Dr. Zane Walsh, Jr. (-/M) 2810 Huntington Road Fayetteville, NC 28303 484-3436/323-9010 (W)	8/08	1 <sup>st</sup>	Dec/09 12/31/09	Yes
(serving unexpired term, eligible for 2 additional full terms)				
<u>Individual with Financial Expertise</u>				
Christopher Bostock (M) 424 Kingsford Road Fayetteville, NC 28314 864-6501/486-0415(W)	12/06	1 <sup>st</sup>	Dec/09 12/31/09	Yes
Willie Cooper, Jr. (B/M) 5599 Ashgrove Drive Fayetteville, NC 28311 488-4037/829-9873 (W)	12/06	1 <sup>st</sup>	Dec/09 12/31/09	Yes
<u>Professional Rep. (Psychology, Social Work, Nursing, Religion)</u>				
Rev. Floyd Johnson, Jr. (B/M) 716 Amber Drive Fayetteville, NC 28311 822-0457	12/04	1 <sup>st</sup>	Dec/08 12/31/08	Yes
<u>Representative with a Family Member or from a Citizen's Organization who Advocates for Persons with a Developmental Disability</u>				
Anna F. Finch (W/F) 3 Skye Place Fayetteville, NC 28303 485-1179	12/02	2 <sup>nd</sup>	Dec/09 12/31/09	No
<u>Drug Abuse Rep. (Family Consumer)</u>				
William H. McDougal (B/M) 661 Country Club Road Fayetteville, NC 28301 488-7311	12/07	2 <sup>nd</sup>	Dec/10 12/31/10	No
<u>Developmental Disabilities (Family Consumer)</u>				
Annie A. Owens (B/F) 186 Wolfpoint Drive Fayetteville, NC 28311 488-2028/483-0153 (W)	08/08	1 <sup>st</sup>	June/10 6/30/10	Yes
(serving unexpired term)				

<u>Name/Address</u>	<u>Date Appointed</u>	<u>Term</u>	<u>Expires</u>	<u>Eligible For Reappointment</u>
<u>Drug Abuse, Primary Consumer, Presently in Recovery</u>				
Gladys Hunt (I/F) 7158 Eagle Spring Drive Hope Mills, NC 28348 425-7409/483-8442(W) Mental Health Board, Page 2	1/06	1 <sup>st</sup> full	Dec/09 12/31/09	Yes
<u>Mental Health Rep. from a Citizens Organization or Primary Consumer</u>				
Luis M. Collazo (H/M) 2051 Merrimac Drive Fayetteville, NC 28314 864-1818/433-1697(W)	12/04	1 <sup>st</sup>	Dec/08 12/31/08	Yes
<u>Mental Health Rep. (Family Consumer)</u>				
Albert Bleakley (W/M) 3018 Ravenhill Drive Fayetteville, NC 28303 484-9406	12/04	2 <sup>nd</sup>	Dec/08 12/31/08	No
<u>Alcoholism (Family Consumer)</u>				
Phyllis M. Spain (B/F) P.O. Box 821 Spring Lake, NC 28390 484-4726/916-4974(W)	06/06 to fill unexp. term	1 <sup>st</sup>	Dec/09 12/31/09	Yes
<u>Alcoholism, Primary Consumer, Presently in Recovery</u>				
Nathan Taylor (B/M) 6819 Mangrove Drive Fayetteville, NC 28314 864-8742	11/04	2 <sup>nd</sup>	Dec/08 12/31/08	No
<u>Individual with Management or Business Expertise</u>				
Liliana C. Parker (W//H/F) PO Box 58064 Fayetteville, NC 28305 433-0791/551-4611 (W)	11-07 filling unexpired term	1 <sup>st</sup>	Dec/09 12/31/09	Yes
<u>At Large Members</u>				
Evelyn O. Shaw (B/F) P.O. Box 1195 Fayetteville, NC 28302 488-3562/323-5303	05/04 to fill unexp. term	2 <sup>nd</sup>	Dec/09 12/31/09	No

Mental Health Board, page 3

<u>Name/Address</u>	<u>Date Appointed</u>	<u>Term</u>	<u>Expires</u>	<u>Eligible For Reappointment</u>
<u>Individual Representing the Interest of Children</u>				
Pam McEvoy (W/F) PO Box 488 Fayetteville, NC 28302-0488 424-0117/486-9700(W)	12/06	1 <sup>st</sup>	Dec/09 12/31/09	Yes
<u>Openly Declared Consumer with Mental Illness</u>				
Nancy Capps (I/F) 1343 Devonshire Drive Fayetteville, NC 28304	12/02	2 <sup>nd</sup>	Dec/09 12/31/09	No

County Commissioner (2)\* (Voting Members) - Billy R. King and Ed Melvin  
Contact: Hank Debnam, Mental Health Director, Ph # 222-6126, Fax # 323-0096  
Meetings: 1<sup>st</sup> Wednesday of the month at 5:15 PM, 711 Executive Place, Board Room 124.

- Board expanded to 18 members 11-06-02.\*
- Board terms changed to 3 year terms as of 6-06

APPLICANTS FOR  
MENTAL HEALTH BOARD

<u>NAME/ADDRESS/TELEPHONE</u>	<u>OCCUPATION</u>	<u>EDUCATIONAL BACKGROUND</u>
CARTER, JAMES M. (W/M) 1212 CASTLEROCK DRIVE FAYETTEVILLE, NC 28304 484-4550/678-9896 (W)	ART-TIME TEACHER MEDIA PRODUCTION FTCC	BS - COMMUNICATIONS MINOR IN ART CONTINUING EDUC.
DAURIA, DAVID (_/M) 6437 PERICAT DRIVE FAYETTEVILLE, NC 28306 425-5771/797-9688 **SERVES ON THE EQUALIZATION AND REVIEW BOARD	INSTRUCTOR FTCC	ASSOCIATE OF SCIENCE HEATING & AIR
DIBB, JENNIFER (W/F) 6500 JACOBS CREEK CIRCLE FAYETTEVILLE, NC 28306 423-5622/797-1342 (W)	SPEECH PATHOLOGIST THERAPY PLAYGROUND, INC	MASTERS IN COMMUNICATION DISORD.
FLOM, DR. JONATHAN (-/-) 3425 MELROSE ROAD FAYETTEVILLE, NC 28304	PSYCHIATRIST BEHAVIORAL HEALTHCARE OF CAPE FEAR VALLEY	B.A. & M.D. – RESIDENCY IN PSYCHIATRY
HALES, DR. MARY A. (B/F) 3490 HASTINGS DRIVE FAYETTEVILLE, NC 28311 482-3390/822-2570	CC SCHOOLS - ADMINISTRATOR	BS – PSYCHOLOGY MA – ELEM. EDUCATION MS – SCHOOL ADMIN. Ed.D – EDUC. LEADERSHIP
HALL, BARBARA M. (W/F) 1305 SKYLINE DRIVE FAYETTEVILLE, NC 28314 495-0603/483-8970 (W)	EXECUTIVE DIRECTOR OF CONTACT CRISIS HELPLINE	BA – SOCIOLOGY (2007) MS IN HUMAN SVS
KIZER, MARYMELDA HALL (W/F) 214 WOODCREST ROAD FAYETTEVILLE, NC 28305 484-0508/868-5131 (W)	LIBRARIAN	BA, MAT ENGLISH
LAVOIE, MARY ELLEN (W/F) PO BOX 53295 FAYETTEVILLE, NC 28305 257-5529	SOCIAL WORKER BIBLICAL COUNSELING	MSW – SOCIAL WORK
LESICA, CATHERINE (W/F) 2910 SWIFTCREEK DRIVE FAYETTEVILLE, NC 28303 867-7784/323-1425 (W)	ATTORNEY MCLEOD LAW FIRM	BS; JD
VASILOPOULOS, NATALIE 1833 CAMELOT DRIVE FAYETTEVILLE, NC 28304 425-5116/(828) 467-9300 (C)	HOMEMAKER	BA – CRIMINAL JUSTICE
VASILOPOULOS, NATALIE 1833 CAMELOT DRIVE FAYETTEVILLE, NC 28304 425-5116/(828) 467-9300 (C)	HOMEMAKER	BA – CRIMINAL JUSTICE

<u>NAME/ADDRESS/TELEPHONE</u>	<u>OCCUPATION</u>	<u>EDUCATIONAL BACKGROUND</u>
WIGGS, CECIL (W/M) 6213 STONEY POINT LOOP FAYETTEVILLE, NC 28306 425-8557	RETIRED CC SCHOOL TEACHER	MASTERS -EDUCATION

J. BREEDEN BLACKWELL  
Chairman

JEANNETTE M. COUNCIL  
Vice Chairman

KENNETH S. EDGE  
JOHN T. HENLEY, JR.  
BILLY R. KING  
EDWARD G. MELVIN  
DIANE WHEATLEY

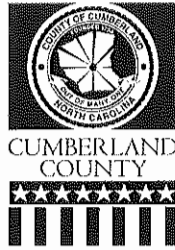

MARSHA S. FOGLE  
Clerk to the Board

MARIE COLGAN  
Deputy Clerk

**BOARD OF COMMISSIONERS**

5th Floor, New Courthouse • P.O. Box 1829 • Fayetteville, North Carolina 28302-1829  
(910) 678-7771 • Fax: (910) 678-7770

ITEM NO. 6F

November 7, 2008

**November 17, 2008 Agenda Item**

TO: Board of Commissioners  
FROM: Marie Colgan, Deputy Clerk *MC*  
SUBJECT: Minimum Housing Appeals Board

The Minimum Housing Appeals Board will have the following vacancy on December 31, 2008:

Alternate Members

**Louis King** – completing first term. Eligible for reappointment.

I have attached the membership list and applicant list for this board.

**PROPOSED ACTION: Make nomination to fill the vacancy.**

pc: Carol Post, Planning/Inspections Department

Attachments

*Celebrating Our Past... Embracing Our Future*

MINIMUM HOUSING APPEALS BOARD  
3 Year Staggered Terms

<u>Name/Address</u>	<u>Date Appointed</u>	<u>Term</u>	<u>Expires</u>	<u>Eligible For Reappointment</u>
Charles Lewis (B/M) PO Box 58583 Fayetteville, NC 28305-8583 238-2351/554-8298 (C)	10/07	1st	Oct/10 10/31/10	Yes
I. J. McNeil(B/M) 821 Oakcrest Drive Fayetteville, NC 28301 822-3152/489-1119 (C)	10/06	2 <sup>nd</sup>	Oct/09 10/31/09	No
Linda J. Miller 5815 Cherrystone Drive Fayetteville, NC 28311 480-0063/822-7923 (W)/987-0289 (C)	10/07	1st	Oct/10 10/31/10	Yes
Clyde V. Vaughan (W/M) 126 West Circle Court Fayetteville, NC 28301 822-4362	10/08	2 <sup>nd</sup>	Oct/11 10/31/11	No
John Williams (B/M) 7712 Guinevere Court Fayetteville, NC 28314 864-9536/875-5081(W)/476-2388 (C)	11/05	1st	Nov/08 11/30/08	Yes
<b><u>(Alternate Members)</u></b>				
Clayton O. Burris, Jr. (W/M) 2026 Forest Hills Drive Fayetteville, NC 28303 822-2800	10/07	1 <sup>st</sup>	Oct/10 10/31/10	Yes
Deborah Ann Dantzler (B/F) 421 Old Farm Road Fayetteville, NC 28314 487-2548/488-2120, ext. 7494(W)/308-2159 (C)	12/07	2 <sup>nd</sup>	Dec/10 12/31/10	No
Leesa Jensen (W/F) 719 Ashfield Drive Fayetteville, NC 28311 630-0253/433-1695 (W)	10/07	1 <sup>st</sup>	Oct/10 10/31/10	Yes

Minimum Housing Appeals Board, Page 2

<u>Name/Address</u>	<u>Date Appointed</u>	<u>Term</u>	<u>Expires</u>	<u>Eligible For Reappointment</u>
Louis L. King (W/M) 1004 Greenhouse Drive Hope Mills, NC 28348 425-3732/797-0260 (C)	12/05	1 <sup>st</sup>	Dec/08 12/31/08	Yes
Geri T. Hasapis ( -/F) 356 Edinburg Drive Fayetteville, NC 28303 864-7433/497-8830	10/08	1 <sup>st</sup>	Oct/11 10/31/11	Yes

Meetings: Quarterly - Second Tuesday of the first month of each quarter per calendar year -  
(January, April, July, October)  
Old Courthouse, 130 Gillespie St., 6:30 PM

Contact: Carol M. Post, 321-6640, Planning and Inspections Department  
Cell: 261-7745 (after 5 pm on the day of the meeting)



APPLICANTS FOR  
MINIMUM HOUSING APPEALS BOARD

<u>NAME/ADDRESS/TELEPHONE</u>	<u>OCCUPATION</u>	<u>EDUCATIONAL BACKGROUND</u>
ARNOLD, KEN (B/M) 1005 OUR STREET FAYETTEVILLE, NC 28314 867-3114/222-2800 (W)	REALTOR KELLER WILLIAMS REALTY	WORKING ON AA DEGREE
BOOTH, YVONNE (B/F) 4568 TURQUOISE RD FAYETTEVILLE, NC 28311 488-7260 <b>**SERVES ON THE ADULT CARE HOME ADVISORY BOARD**</b>	STUDENT	MEDICAL/ EDUC CNA MED TECH, PHLEBOTOMY TECH
BRIGGS, BENITA Y. (B/F) 1116 BINGHAM DRIVE FAYETTEVILLE, NC 28304 822-1154/672-1294 (W) <b>**SERVES ON THE ADULT CARE HOME ADVISORY BOARD**</b>	OFFICE ASSISTANT IV FSU	A IN HISTORY; 08 RAD – BA IN SOCIOLOGY
BRIGGS, DR. JOHN G. (W/M) 2910 HYBART STREET FAYETTEVILLE, NC 28303 867-1493 <b>**SERVES ON THE NURSING HOME ADVISORY BOARD**</b>	RETIRED PLASTIC SURGEON	DR OF MEDICINE BS – BIOLOGY
COLEY, TIAWANNIA A. (B/F) 6115 LAKE TRAIL DRIVE FAYETTEVILLE, NC 28304 860-4872/321-6794 (W)	SUBSTANCE ABUSE COUNSELOR - MENTAL HEALTH/TASC	BS – COMPUTER SCIENCE AA – MATHEMATICS WORKING ON MASTERS - MH COUNSELING
HAIR, ANTHONY D. (B/M) 6344 MURPHY ROAD STEDMAN, NC 28391 486-9794/592-1575 (W)	CUSTOMER SOLUTIONS REP - EMBARQ	BS – EDUCATION
HOGAN, STEVE (W/M) 4585 CANASTA COURT HOPE MILLS, NC 28348 868-9807/797-1910	REAL ESTATE BROKER RE/MAX ALLSTARS	BA – POLITICAL SCIENCE
McNEILL, ELVIN (B/M) 2280 SPINDLETREE DRIVE FAYETTEVILLE, NC 28304 423-7027/677-2552	SOCIAL WORKER DSS	BS – MATH

J. BREEDEN BLACKWELL  
Chairman

JEANNETTE M. COUNCIL  
Vice Chairman

KENNETH S. EDGE  
JOHN T. HENLEY, JR.  
BILLY R. KING  
EDWARD G. MELVIN  
DIANE WHEATLEY



MARSHA S. FOGLE  
Clerk to the Board

MARIE COLGAN  
Deputy Clerk

**BOARD OF COMMISSIONERS**

5th Floor, New Courthouse • P.O. Box 1829 • Fayetteville, North Carolina 28302-1829  
(910) 678-7771 • Fax: (910) 678-7770

November 12, 2008

ITEM NO. 66

**November 17, 2008 Agenda Item**

TO: Board of Commissioners  
FROM: Marie Colgan, Deputy Clerk *MC*  
SUBJECT: Nursing Home Advisory Board

The Nursing Home Advisory Board has the following vacancy:

Lora Watson – has resigned. Please fill the vacancy.

I have attached the current membership and applicant lists for this board.

**PROPOSED ACTION: Make nomination to fill the vacancy.**

Attachments

pc: Andrea Wright-Valdez, Mid-Carolina Area Agency on Aging

*Celebrating Our Past... Embracing Our Future*

NURSING HOME ADVISORY BOARD  
3 Year Term  
(Initial Appointment One Year)

<u>Name/Address</u>	<u>Date Appointed</u>	<u>Term</u>	<u>Expires</u>	<u>Eligible For Reappointment</u>
Mandella Edwards ( /F) 7076 Candlewood Drive Fayetteville, NC 28314 429-0790(H)	4/07	1 <sup>st</sup>	April/10 4/30/10	Yes
Tom Lloyd (W/M) 1306 Berkshire Road Fayetteville, NC 28305 574-3177/678-7618(W)	8/08	1 <sup>st</sup>	Aug/11 8/31/11	Yes
Martha McKoy P.O. Box 42152 Fayetteville, NC 28309 423-0771	9/08	2 <sup>nd</sup>	Sept/11 9/30/11	No
Dr. John Briggs (W/M) 2910 Hybart Street Fayetteville, NC 28303 867-1493	2/08	Initial	Feb/09 2/28/09	Yes
William R. Nichols(W/M) 1240 Magnolia Church Road Stedman, NC 28391 483-3934/433-1924(W)	2/07	1 <sup>st</sup>	Feb/10 2/28/10	Yes
Hervenna Pannell (B/F) 1821 Eichelberger Drive Fayetteville, NC 28303 822-8516/907-9355(W)	2/06	1 <sup>st</sup>	Feb/09 2/28/09	Yes
Clyde E. Hammond (W/M) 1802 Flintshire Road Fayetteville, NC 28304 425-2774	08/08	1 <sup>st</sup>	Aug/11 8/31/11	Yes
Teresa Rena McNeill (B/F) 3518 Pickerel Street Fayetteville, NC 28306 480-0313/483-3648 x2226 (W)	8/08	1 <sup>st</sup>	Aug/11 8/31/11	Yes
Toney Edwards (B/M) 3622 Clearwater Drive Fayetteville, NC 28311 822-4261/864-6262	1/08	Initial	Jan /09 1/31/09	Yes

<u>Name/Address</u>	<u>Date Appointed</u>	<u>Term</u>	<u>Expires</u>	<u>Eligible For Reappointment</u>
Stephanie Hodges (W/F) 3424 Harrisburg Road Fayetteville, NC 28306 429-9300/292-5651 (C)	6/08	1 <sup>st</sup>	June/11 6/30/11	Yes
Lora L. Watson 1516 Chedington Road Hope Mills, NC 28348 485-3558/824-0993	4/07	2 <sup>nd</sup>	April/10 4/30/10	No

CONTACT: Andrea Wright-Valdez, Mid-Carolina Area Agency on Aging  
P. O. Box 1510, Fayetteville, NC 28302, (Phone: 323-4191, ext. 25)

Quarterly, (March, June, September & December) at 1:00 PM on the 3<sup>rd</sup> Thursday - at various nursing homes in the county.

APPLICANTS FOR  
NURSING HOME ADVISORY BOARD

<u>NAME/ADDRESS/TELEPHONE</u>	<u>OCCUPATION</u>	<u>EDUCATIONAL BACKGROUND</u>
BOOTH, YVONNE (B/F) 4568 TURQUOISE RD FAYETTEVILLE, NC 28311 488-7260 <b>**SERVES ON THE ADULT CARE HOME ADVISORY BOARD**</b>	STUDENT	MEDICAL/ EDUC CNA MED TECH, PHLEBOTOMY TECH
CARAMANNO, DELL (W/F) 5578 QUIETWOOD PLACE FAYETTEVILLE, NC 28304 423-2622 <b>**SERVES ON THE ADULT CARE HOME COMMUNITY ADVISORY COMMITTEE**</b>	RETIRED	SOME COLLEGE
EBRON, SANDRA (B/F) PO BOX 65306 FAYETTEVILLE, NC 28306 424-3932/(919) 922-9446 (C)	UTILIZATION MGT SPECIALIST MENTAL HEALTH – LUMBERTON	MASTERS – SOCIAL WORK
HACKETT, MARIAN J. (B/F) 4184 FERNCREEK DRIVE FAYETTEVILLE, NC 28314 323-3060/672-2129 <b>**SERVES ON THE ADULT CARE HOME COMMUNITY ADVISORY COMMITTEE**</b>	RN – LECTURER FSU	MASTER – NURSING
HAIRE, CASSANDRA W. (B/F) 515 ALBANY STREET FAYETTEVILLE, NC 28301 728-0175	SELF EMPLOYED	PURSUING MBA
HOMER, MARILYN ( /F) 701 EMELINE AVENUE FAYETTEVILLE, NC 28303 678-8020/609-0639 (W)	ADVERTISING/MARKETING SERVICES MANAGER THE FAYETTEVILLE OBSERVER	BA/GENERAL STUDIES
PAUL, ROBIN (B/F) 363 KIMBERWICKE DRIVE FAYETTEVILLE, NC 28311 424-2278/237-2829 (W)	SELF-EMPLOYED CARE FINDERS FIRST	MASTERS-TEACHING READING K-6
TOMLINSON-KNOELL, REV. NANETTE 609 TALLSTONE DRIVE FAYETTEVILLE, NC 28311 339-2201/489-2198 <b>**SERVES ON THE ADULT CARE HOME COMMUNITY ADVISORY COMMITTEE**</b>	PASTOR	BA – ELEMENTARY EDUC. MASTER OF DIVINITY
WOLFE, JACQUELINE B. (W/F) 1812 MANCHESTER STREET FAYETTEVILLE, NC 28303 484-8588/484-5146 (W) <b>**SERVES ON THE ADULT CARE HOME COMMUNITY ADV. BOARD**</b>	RETIRED - FAYETTEVILLE POSTAL CU	HS; SOME TECH COURSES

J. BREEDEN BLACKWELL  
Chairman

JEANNETTE M. COUNCIL  
Vice Chairman

KENNETH S. EDGE  
JOHN T. HENLEY, JR.  
BILLY R. KING  
EDWARD G. MELVIN  
DIANE WHEATLEY



MARSHA S. FOGLE  
Clerk to the Board

MARIE COLGAN  
Deputy Clerk

**BOARD OF COMMISSIONERS**

5th Floor, New Courthouse • P.O. Box 1829 • Fayetteville, North Carolina 28302-1829  
(910) 678-7771 • Fax: (910) 678-7770

November 12, 2008

**November 17, 2008 Agenda Item**

TO: Board of Commissioners  
FROM: Marie Colgan, Deputy Clerk *MC*  
SUBJECT: Transportation Advisory Board

ITEM NO. 6H

The Transportation Advisory Board will have the following vacancies on November 30, 2008:

City of Fayetteville Representatives

Victor Sharpe - completing second term. Not eligible for reappointment. The Transportation Advisory Board has recommended that **Adolphus Thomas** fill this vacancy (see attached).

County Planning Department Director or Designee

Tom Lloyd - completing second term. Not eligible for reappointment. The Transportation Advisory Board has recommended that **Cecil Combs** fill this vacancy (see attached).

I have attached the current membership list and applicant list for this board.

**PROPOSED ACTION:** Make nominations to fill the two (2) vacancies.

pc: Kristine Wagner, Transportation Program Coordinator  
Planning & Inspections Department

*Celebrating Our Past... Embracing Our Future*

Tom Lloyd  
Chairman

Victor Sharpe, AICP  
Vice Chairman

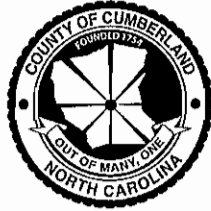

Kristine Wagner  
Transportation Coordinator

130 Gillespie Street  
Fayetteville, NC 28301  
910-678-7624  
[kwagner@co.cumberland.nc.us](mailto:kwagner@co.cumberland.nc.us)

CUMBERLAND COUNTY  
TRANSPORTATION ADVISORY BOARD

---

November 12, 2008

**MEMORANDUM**

TO: Marie Colgan  
FROM: Kristine Wagner, Transportation Program Coordinator  
SUBJECT: TAB Member Terms

The Transportation Advisory Board has voted to nominate the following individuals:

Mr. Cecil Combs (to replace Thomas Lloyd)  
Mr. Adolph Thomas (to replace Victor Sharpe)

The following board member is yet to be replaced. Their position shall remain vacant until a new appointment is made:

Mr. Wally Ainsworth

If you have any questions or need any additional information please contact me.

TRANSPORTATION ADVISORY BOARD  
2 Year Term  
(Staggered 2 & 3 Year Terms Initially)

Name/Address	Date Appointed	Term	Expires	Eligible For Reappointment
<u>City of Fayetteville Representative</u>				
Victor Sharpe Community Development Director City of Fayetteville 433 Hay Street Fayetteville, NC 28301 433-1601	11/06	2 <sup>nd</sup>	Nov/08 11/30/08	No
<u>Urban Transit Provider Representative</u>				
Vacant (not required by State)				
<u>Mid-Carolina Council of Governments Director or Designee</u>				
Carolyn Tracy Mid-Carolina Council of Governments P.O. Box 1510 Fayetteville, North Carolina 28302-1510	11/07	2 <sup>nd</sup>	Nov/09 11/30/09	No
<u>County DSS Director or Designee</u>				
Crystal Black Cumberland County DSS P.O. Box 2429 Fayetteville, North Carolina 28302-2429	11/07	2 <sup>nd</sup>	Nov/09 11/30/09	No
<u>DSS Work First Representative</u>				
Ann Farrell Cumberland County DSS P.O. Box 2429 Fayetteville, North Carolina 28302-2429	11/07	2 <sup>nd</sup>	Nov/09 11/30/09	No
<u>Workforce Development Center Director or Designee</u>				
Geneva Mixon Workforce Development Center 410 Ray Avenue Fayetteville, North Carolina 28301	11/07	2 <sup>nd</sup>	Nov/09 11/30/09	No
<u>Vocational Rehab Representative</u>				
Tammy Jackson Vocational Rehab – Independent Living 1200 Fairmont Court Fayetteville, NC 28304 486-1717	11/06	1 <sup>st</sup>	Nov/08 11/30/08	Yes



<u>Name/Address</u>	<u>Date Appointed</u>	<u>Term</u>	<u>Expires</u>	<u>Eligible For Reappointment</u>
<u>Sheltered Workshop Director or Designee</u>				
Betsy Torsell Employment Source 600 Ames Street Fayetteville, NC 28301	11/07	1 <sup>st</sup>	Nov/09 11/30/09	Yes
<u>Aging Programs Representative</u>				
Catherine VanSickle Cumberland County Coordinating Council On Older Adults 339 Devers Street Fayetteville, North Carolina 28303	11/07	2 <sup>nd</sup>	Nov/09 11/30/09	No
<u>County Mental Health Director or Designee</u>				
William H. Robinson CC Area Mental Health Center 109 Bradford Avenue Fayetteville, North Carolina 28301-5496 323-0601(W)	11/07	1 <sup>st</sup>	Nov/09 11/30/09	Yes
<u>Emergency Medical Services Representative</u>				
Wally Ainsworth Cumberland County EMS 610 Gillespie Street Fayetteville, North Carolina 28306 609-5600 (W)	11/06	2 <sup>nd</sup>	Nov/08 11/30/08	No
<u>County Representative</u>				
Vacant (not required)				
<u>County Planning Department Director or Designee</u>				
Tom Lloyd Cumberland County Planning Department P.O. Box 1829 Fayetteville, North Carolina 28302-1829	11/06	2 <sup>nd</sup>	Nov/08 11/30/08	No
<u>County Health Director or Designee</u>				
Sharon Stanley Cumberland County Health Dept. 227 Fountainhead Lane Fayetteville, North Carolina 28301	11/05	2 <sup>nd</sup>	Nov/07 11/30/07	No

<u>Name/Address</u>	<u>Date Appointed</u>	<u>Term</u>	<u>Expires</u>	<u>Eligible For Reappointment</u>
<u>At-Large Representatives</u>				
Charles Luther, Jr. LaFayette Council of the Blind 1509 Cardiff Drive Fayetteville, NC 28304 867-5554	11/06	1 <sup>st</sup>	Nov/08 11/30/08	Yes
Dianne Grumelot Cumberland County Schools 1014 Gillespie Street Fayetteville, North Carolina 28306 678-2586	11/06	1 <sup>st</sup>	Nov/08 11/30/08	Yes
Timothy Joel Strickland Mid-Carolina COG P.O. Drawer 1510 Fayetteville, NC 28302 323-4191, ext. 34(W)	11/06	1 <sup>st</sup>	Nov/08 11/30/08	Yes
Pam Presser Dept. of Social Services 1225 Ramsey Street Fayetteville, North Carolina 28301 677-2531	11/06	2 <sup>nd</sup>	Nov/08 11/30/08	No

\*\*Board was created by the Commissioners on 11/6/00.

Meetings: Second Tuesday in first month of Quarter at 11:00 AM.

Location: Historic Courthouse, Courtroom #3

Contact: Kristine Wagner (Planning & Inspections) x7624, fax # 678-7601

(Terms must expire in November according to Bylaws.)

APPLICANTS FOR  
TRANSPORTATION ADVISORY BOARD

<u>NAME/ADDRESS/TELEPHONE</u>	<u>OCCUPATION</u>	<u>EDUCATIONAL BACKGROUND</u>
COLLINS, RICKEY (W/M) 4876 US HWY 3015 HOPE MILLS, NC 28348 425-9990	RETIRED ELECTRICIAN NC	SOME COLLEGE ELEC. LICENSE
COMBS, CECIL P. (- /M) 5501 BIRDIE COURT HOPE MILLS, NC 28348	DEPUTY DIRECTOR, CC PLANNING & INSPECTIONS	BA – HISTORY
FARRAKHAN, IFETAYO (B/F) 4608 PINE NEEDLE COURT FAYETTEVILLE, NC 28314 339-9101/677-2313 (W)	LEAD WORKER-TRANSPORTATION DSS	HS GRAD; SOME COLLEGE
MARSHALL, BARBARA SUMMEY (B/F) 7640 WILKINS DRIVE FAYETTEVILLE, NC 28311 488-2615/977-2303 (W)	VOLUNTEER/ADVOCATE RETIRED MILITARY  <b>**SERVES ON BOARD OF HEALTH**</b>	MASTERS - RELIGIOUS EDUCATION
McALLISTER, MEREDITH (B/F) 553 HOLLYBERRY LANE FAYETTEVILLE, NC 28314 867-8564/222-8751 (W)	CERTIFIED PERSONAL FINANCE COUNSELOR - CONSUMER EDUCATION SERVICES	BUSINESS – UNC AT CHAPELL HILL
MITCHELL, SANDRA (B/F) 121 MULLINS AVENUE FAYETTEVILLE, NC 28301 483-2978/323-2732 (W)	BUSINESS OWNER SANDY'S FASHION BOUTIQUE	HS; VOCATIONAL TRNG
OKHOMINA, DR. DON A. (B/M) 494 DUNLOE COURT FAYETTEVILLE, NC 28311 868-1618/672-2148 (W)	ASST PROFESSOR OF MANAGEMENT - FSU	BS – BUSINESS ADMIN MBA, PHD – MGT.
PITTMAN, RONALD (WM) 813 KATIE STREET FAYETTEVILLE, NC 28306 485-1230/624-0754	REALTOR/BROKER	NOT LISTED
SANTIAGO, JOSEPH (B/M) 7935 LESTER DRIVE FAYETTEVILLE, NC 28311-7420 213-5345/670-4143 (W)	PAINT & BODY RESTORATION BULLY BREED CUSTOM PAINT & BODY	NOT LISTED

J. BREEDEN BLACKWELL  
Chairman

JEANNETTE M. COUNCIL  
Vice Chairman

KENNETH S. EDGE  
JOHN T. HENLEY, JR.  
BILLY R. KING  
EDWARD G. MELVIN  
DIANE WHEATLEY

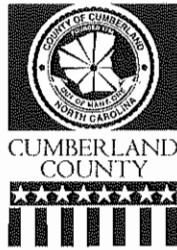

MARSHA S. FOGLE  
Clerk to the Board

MARIE COLGAN  
Deputy Clerk

**BOARD OF COMMISSIONERS**

5th Floor, New Courthouse • P.O. Box 1829 • Fayetteville, North Carolina 28302-1829  
(910) 678-7771 • Fax: (910) 678-7770

ITEM NO. 7A

November 6, 2008

**November 17, 2008 Agenda Item**

TO: Board of Commissioners  
FROM: Marie Colgan, Deputy Clerk *MC*  
SUBJECT: Board of Adjustment

**BACKGROUND:** On November 3, 2008 the Board of Commissioners nominated the following to fill one vacancy on the Board of Adjustment:

Alternate Member - **William Lockett Tally** (new appointment)

I have attached the current membership list for this Board.

**PROPOSED ACTION:** **Appoint the above vacancy.**

Attachment

pc: Tom Lloyd, Director  
Planning/Inspection Department

*Celebrating Our Past... Embracing Our Future*

BOARD OF ADJUSTMENT  
3 Year Term

<u>Name/Address</u>	<u>Date Appointed</u>	<u>Term</u>	<u>Expires</u>	<u>Eligible For Reappointment</u>
Joseph M. Dykes (B/M) 5764 Pepperbush Drive Fayetteville, NC 28304 423-5255/322-0602 (W)	1/08  (serving unexpired term)	1st	June/09 6/30/09	Yes
Oscar L. Davis, III (C/M) 3320 Rustburg Drive Fayetteville, NC 28303 867-2950/977-3101(W)	6/07	2 <sup>nd</sup>	June/10 6/30/10	No
Melree Hubbard Tart (W/F) 300 Andrews Road Fayetteville, NC 28311 488-1208/497-3712 (W)	6/07	1 <sup>st</sup>	Aug/10 8/31/10	Yes
Steve Parsons(W/M) 3701 Clearwater Drive Fayetteville, NC 28311 822-4155/822-2000(W)	9/06	2nd	Sept/09 9/30/09	No
George Quigley (W/M) 618 Blawell Circle Stedman, NC 28391 485-2980/321-6882	6/06	1st	June/09 6/30/09	Yes
<u>Alternate Members:</u>				
Carrie Tyson-Autry (_/F) 5951 NC Hwy 87 South Fayetteville, NC 28306-379 483-0087	6/08	1 <sup>st</sup>	Aug/10 8/31/10	Yes
Horace Humphrey (- /M) 1852 Cascade Street Fayetteville, NC 28301 488-5143	01/08  (serving unexpired term)	1st	Aug/10 8/31/10	Yes
James Ingram (B/M) PO Box 87671 Fayetteville, NC 28304 257-1831/488-8415 (W)	6/07	1 <sup>st</sup>	June/10 6/30/10	Yes

<u>Name/Address</u>	<u>Date Appointed</u>	<u>Term</u>	<u>Expires</u>	<u>Eligible For Reappointment</u>
---------------------	-----------------------	-------------	----------------	-----------------------------------

Alternate Members Continued:

John R. Swanson (W/M) 6416 Coachman's Way Fayetteville, NC 28303 987-1972/822-2000 (W)	6/07  (filling unexpired term)	1 <sup>st</sup>	Jan/10 1/31/10	Yes
---	--------------------------------------	-----------------	-------------------	-----

Martin J. Locklear (I/M) 1611 Four Wood Drive Fayetteville, NC 28312 672-0323/893-7525(W)	8/06	1 <sup>st</sup>	Aug/09 8/31/09	Yes
--	------	-----------------	-------------------	-----

Meets 3<sup>rd</sup> Thursday of each month at 7:00 PM – Historic Courthouse, Room 3

Contact: Tom Lloyd, Planning Department - 678-7618

J. BREEDEN BLACKWELL  
Chairman

JEANNETTE M. COUNCIL  
Vice Chairman

KENNETH S. EDGE  
JOHN T. HENLEY, JR.  
BILLY R. KING  
EDWARD G. MELVIN  
DIANE WHEATLEY

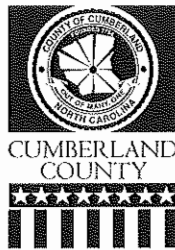

MARSHA S. FOGLE  
Clerk to the Board

MARIE COLGAN  
Deputy Clerk

**BOARD OF COMMISSIONERS**

5th Floor, New Courthouse • P.O. Box 1829 • Fayetteville, North Carolina 28302-1829  
(910) 678-7771 • Fax: (910) 678-7770

ITEM NO. 7B

November 6, 2008

**November 17, 2008 Agenda Item**

TO: Board of Commissioners  
FROM: Marie Colgan, Deputy Clerk *MC*  
SUBJECT: Cumberland County Emergency Planning Committee

BACKGROUND: On November 3, 2008, the Board of Commissioners nominated the following to fill one vacancy on the above Committee:

Operators of Facilities Representative: **Catherine Grazioli** (new appointment)  
(Safety Manager – Hexion Specialty Chemicals)

I have attached the current membership list for this committee.

**PROPOSED ACTION: Appoint the above vacancy.**

Attachment

pc: Kenny Currie, Emergency Services Director

*Celebrating Our Past... Embracing Our Future*

CUMBERLAND COUNTY  
EMERGENCY PLANNING COMMITTEE  
3 Year Term  
(Staggered Terms Initially)

Name/Address	<u>Date</u> Appointed	Term	Expires	<u>Eligible For</u> Reappointment
<u>Print and Broadcast Media Representative</u>				
Doug Hewett, Director City of Fayetteville Management Services 433 Hay Street Fayetteville, NC 28301 Phone: 433-1978	8/07	1 <sup>st</sup> full	Aug/10 8/31/10	Yes
Sarah VanderClute CC Public Information Officer P.O. Box 1829 Fayetteville, NC 28302 Phone: 437-1921	8/07	2 <sup>nd</sup>	Aug/10 8/31/10	No
<u>Operators of Facilities Representative</u>				
(vacant) Safety Manager Hexion Specialty Chemicals 1411 Industrial Drive Fayetteville, NC 28301 485-9270	10/05	2 <sup>nd</sup>	Nov/08 11/30/08	No
(vacant) Univar, Inc. 420 Worth Street Fayetteville, NC 28304 483-2107/988-2801	9/03	1 <sup>st</sup>	Sept/06 9/30/06	Yes
Joel Blake Dupont 22828 NC Hwy 87W Fayetteville, NC 28306 424-4083/678-1285(W)	4/07	2 <sup>nd</sup>	Dec/09 12/31/09	No
(vacant) Purolator Corp. 3200 Natal Road Fayetteville, NC 28306 423-5691/426-4283(W)	4/07	2 <sup>nd</sup>	Dec/09 12/31/09	No



<u>Name/Address</u>	<u>Date Appointed</u>	<u>Term</u>	<u>Expires</u>	<u>Eligible For Reappointment</u>
<u>Law Enforcement Representative</u>				
Sgt. Erwin Montgomery NC Highway Patrol 2435 Gillespie Street (filling unexpired term) Fayetteville, NC 28306-3053 486-1334	6/08	1 <sup>st</sup>	Sept/09 9/30/09	Yes
Lt. Charles Parker Cumberland Co. Sheriff's Office 131 Dick Street Fayetteville, NC 28301-5750 (filling unexpired term) 677-5412	5/08	1 <sup>st</sup>	Aug/10 8/31/10	Yes
Lt. Charles F. Kimble Fayetteville Police Department 467 Hay Street (filling unexpired term) Fayetteville, NC 28301 433-1850	6/08	1 <sup>st</sup>	Sept/09 9/30/09	Yes
<u>Emergency Management Representative</u>				
Greg Phillips Cumberland County Emergency Services 131 Dick Street Fayetteville, NC 28301 (filling unexpired term) 321-6736	5/08	1 <sup>st</sup>	Sept/10 9/30/10	Yes
<u>Community Group Representative</u>				
Jeffrey Womble Fayetteville State University Office of Public Relations 1200 Murchison Road Fayetteville, NC 28301 Phone:	8/07	2 <sup>nd</sup>	Aug/10 8/31/10	No
<u>Transportation Representative</u>				
David Boyette 466 Baywood Road Fayetteville, NC 28301 485-2439/433-4468(W)/670-0954 (C)	4/07	2 <sup>nd</sup>	Dec/09 12/31/09	No
<u>Health Representative</u>				
Jane Stevens Cumberland County Health Dept. 227 Fountainhead Lane Fayetteville, NC 28301-5417 433-3673(W)/987-2892(Cell)	2/06	1 <sup>st</sup>	Jan/09 1/31/09	Yes

Cumberland County Emergency Planning Committee, page 3

<u>Name/Address</u>	<u>Date Appointed</u>	<u>Term</u>	<u>Expires</u>	<u>Eligible For Reappointment</u>
<u>Hospital Representative</u>				
Steve Schultz Cape Fear Valley Health System P.O. Box 2000 1638 Owen Drive Fayetteville, NC 28302-2000 Phone: 609-6170	9/06	2 <sup>nd</sup>	Sept/09 9/30/09	No
<u>Fire Fighting Representative</u>				
Capt. Benjamin Major Fire/Emergency Management City of Fayetteville 433 Hay Street Fayetteville, NC 28301 433-1730	10/05	2 <sup>nd</sup>	Nov/08 11/30/08	No
<u>First Aid Representative</u>				
Wally Ainsworth Cumberland County EMS 610 Gillespie Street Fayetteville, NC 28306-1544 609-5600	11/07	1 <sup>st</sup>	Nov/10 11/30/10	Yes
<u>At-Large Representative</u>				
Bill Cross 2086 Tailwinds Road Fayetteville, NC 28312 (filling unexpired term) 222/8893/429-4217	6/08	1 <sup>st</sup>	Dec/09 12/31/09	Yes
Dawn O'Donnell 2072 Birchcreeft Drive Fayetteville, NC 28304 425-3619/864-2470(W)	8/07	2 <sup>nd</sup>	Aug/10 8/31/10	No
<u>Local Environmental Representative</u>				
Hughie White NC Dept. of Environment, Health & Natural Resources 225 Green Street, Suite 714 Fayetteville, NC 28301-5043 486-1541	9/06	2 <sup>nd</sup>	Sept/09 9/30/09	No

<u>Name/Address</u>	<u>Date Appointed</u>	<u>Term</u>	<u>Expires</u>	<u>Eligible For Reappointment</u>
<u>Utilities Representative</u>				
John Ezzelle Public Works Commission 955 Old Wilmington Road Fayetteville, NC 28301 223-4116	9/06	1 <sup>st</sup>	Sept/09 9/30/09	Yes
Suzanne Rohrs Attn: Environmental Branch HQ XVIII Airborne Corps Public Works Business Center (filling unexpired term) Fort Bragg, NC 28307 396-7432	6/08	1 <sup>st</sup>	Aug/10 8/31/10	Yes

Ex-Officio Members

Elected Official Representative (Liaison)

Ed Melvin, County Commissioner

Emergency Management

Kenny Currie, Cumberland County Emergency Services

Fayetteville Fire/Emergency Management

Bennie Nichols, Chief, Fayetteville Fire Department

Dale Iman, City Manager

James Martin, County Manager

Contact: Kenny Currie, Director – Emergency Services – x7688 or Gloria Simms

Meets quarterly, 4<sup>th</sup> Thursday in January, April, July & October at 10:00 am – PWC Bldg.