AGENDA
CUMBERLAND COUNTY BOARD OF COMMISSIONERS
COURTHOUSE – ROOM 118
APRIL 20, 2009
6:45 PM

INVOCATION - Commissioner Jeannette Council, Chairman

PLEDGE OF ALLEGIANCE –

PUBLIC COMMENT PERIOD (6:45 PM – 7:00 PM)

Recognition of Outgoing Board Members:

Wendall Troy, Cumberland County Workforce Development Board

1. Consent Agenda

- A. Approval of minutes for the April 6, 2009 regular meeting.
- B. Approval of Proposed Additions to the State Secondary Road System:

Stone Creek Subdivision: Holloman Drive, Rockrose Drive
Lemuel Farm Road, Bexley Court
- C. Approval of Sale of Surplus County-Owned Real Property Acquired by Tax Foreclosure – PIN: 0428-97-5847, Cross Creek Township.
- D. Approval of Sale of Surplus County-Owned Real Property Acquired by Tax Foreclosure – PIN: 9495-08-9444, Seventy-First Township.
- E. Approval of Insurance Claim for Grahams Construction - Courthouse Lobby Addition Project.
- F. Approval of Community Development Affirmative Marketing Policy and Procedures.
- G. Approval of Transfer of Ten (10) MTS-2000 Radios from Cumberland County Sheriff's Office to the Bethany Rural Fire Department.

- H. Approval of Declining Right of First Refusal for Board of Education Surplus Property, Eastover Civic Center, Proposed to be Conveyed to the Town of Eastover.
- I. Approval of Request to Schedule a Public Hearing on May 4, 2009 for Taxpayers' Request for a Refund for Overpayment of Excise Tax Pursuant to NCGS 105-228.37.
- J. Approval of PWC Request for Grant of a Water and Sewer Easement at Western Elementary School and County Library Site.
- K. Approval of a Resolution of Intent to Exchange with Shooters Supply Certain Personal Property Declared Surplus by Sheriff.
- L. Approval of Resolution of Approval of Tax-Exempt Loan to Cotton Fire Department to Build an Addition to Its Fire Station.
- M. Approval of a Proclamation Proclaiming April 26-May 2, 2009 as "Air Quality Week" in Cumberland County.
- N. Approval of a Proclamation Proclaiming May 2009 as Industry Appreciation Month.
- O. Approval of a Proclamation Proclaiming May as Workforce Development Professionals Month.
- P. Approval of a Proclamation Proclaiming 2009 as the "Year of the NCO".
- Q. Budget Revisions:
 - (1) Soil Conservation Cost Share

Revision in the amount of \$521 to appropriate fund balance to roll forward the unexpended Technical Assistance Grant from FY2008. (B09-335) **Funding Source - Grant**
 - (2) Civic Center/Hotel Motel Occupancy Tax Fund

Revisions in the amount of \$250,000 to transfer funds from Hotel/Motel Occupancy Tax Fund to fund necessary capital replacement items at the Crown Coliseum. (B09-340 and B09-340A) **Funding Source -Hotel/Motel Occupancy Tax**

(3) Governing Body

Revision in the amount of \$16,500 to appropriate fund balance to budget costs associated with the retirement of the Clerk to the Board of County Commissioners and the training of a replacement.
(B09-344) **Funding Source – Fund Balance – General Fund**

2. Public Hearings

Contested Cases – Conditional Use

- A. Case P09-06. Rezoning of 99.63+/- acres from PND Planned Neighborhood Development and R6 Residential to MXD Mixed Use Development/CUD Conditional Use District and the Permit, or to a more restrictive zoning district, located on the south side of SR 1611 (Andrews Road) and west of SR 1612 (Farmers Road), submitted by Attorney and General Manager Alfred E. Cleveland, owned by Andrews Road Company, LLC.

Minimum Housing Code Enforcement Cases

- B. Case Number: MH5632-2008
Property Owner: Willie B. & Rosalyn Y. Shaw
Property Location: 2301 Enloe Street, Fayetteville, NC
Parcel Identification Number: 0416-81-8119
- C. Case Number: MH5666-2008
Property Owner: Luther & Catherine Whitehead
Property Location: 7635 Cannery Drive, Dunn, NC (Cumberland County)
Parcel Identification Number: 1504-60-7465
- D. Case Number: MH5565-2008
Property Owners: Beulah H. Gerhart, Michael D. & Peggy T. Canady
Property Location: 5136 Matt Hair Road, Fayetteville, NC
Parcel Identification Number: 0452-92-5181
- E. Case Number: MH5551-2008
Property Owner: Carole B. Marshall Life Estate
Property Location: 6159 Butler Nursery Road, Fayetteville, NC
Parcel Identification Number: 0451-08-0289
- F. Case Number: MH5703-2008
Property Owner: Alberta C. Baker Heirs
Property Location: 1828 Smith Road, Fayetteville, NC
Parcel Identification Number: 0433-91-2146

- G. Case Number: MH5530-2008
Property Owner: Diane Crisp Godwin
Property Location: 3943 Camden Road
Parcel Identification Number: 0425-14-5774
- H. Case Number: MH5512-2008
Property Owner: N. J. Thaggard Heirs, c/o Elvoir Fisher
Property Location: 7011 Huffman Drive, Fayetteville, NC
Parcel Identification Number: 0460-10-1862
- I. Case Number: MH5729-2008
Property Owner: Stephanie L. Baker
Property Location: 5905 St. Michaels Drive, Fayetteville, NC
Parcel Identification Number: 0454-51-5679
- J. Case Numbers: MH5716 and MH5717-2008
Property Owner: Betty R. Smith, c/o Charles Allen Smith
Property Location: 1395, 1399, 1403 and 1407 Tom Starling Road, Fayetteville, NC
Parcel Identification Numbers: 0433-85-2853 and 0433-85-4831

Other Public Hearings

- K. Consideration of the Cumberland County 2030 Growth Vision Plan and the Land Use Policies Plan. (Both documents are intended to give direction to County and Municipal Governments within Cumberland County in reviewing development proposals; planning growth-related facilities and services; preparing standards and regulations; working together on growth management issues, and establishing applicable budget and work program priorities.)
- L. Public Hearing – 2009 Draft Community Development Annual Action Plan.

Items of Business

- 3. Consideration of Amending Chapter 3 of the Cumberland County Code to Refer to the “Animal Services Department” and the “Animal Services Director”.
- 4. Nominations to Boards and Committees:
 - A. Adult Care Home Community Advisory Committee (1 Vacancy)
 - B. Criminal Justice Partnership Advisory Board (2 Vacancies)
 - C. Transportation Advisory Board (2 Vacancies)

5. Appointments to Boards and Committees

- A. Adult Care Home Community Advisory Committee (1 Vacancy)

Nominee: Terri Thomas

- B. Cumberland County Home and Community Care Block Grant (1 Vacancy)

Nominee:

Aging Service Provider: Mary Brymer

- C. Joint Senior Citizens Advisory Board (1 Vacancy)

Nominee: Marlene Jacobs

- D. Mental Health Board (1 Vacancy)

Nominee:

Alcoholism, Family Consumer: Dr. Jo Beth Cain

- E. Nursing Home Advisory Board (1 Vacancy)

Nominee: Cassandra W. Haire

- F. Tourism Development Authority (1 Vacancy)

Nominee:

Hotel/Motel Under 100 Rooms Representative: William S. Wellons, Jr.

6. Closed Session: A. Attorney-Client Matter(s)
Pursuant to NCGS 143-318.11(a)(3).

ADJOURN

**THIS MEETING WILL BE BROADCAST LIVE ON TIME WARNER
COMMUNITY CHANNEL 7.**

**MEETINGS: May 4, 2009 (Monday) - 9:00 AM
May 18, 2009 (Monday) - 6:45 PM**

JAMES E. MARTIN
County Manager

JUANITA PILGRIM
Deputy County Manager



ITEM NO. 1B

AMY H. CANNON
Assistant County Manager

OFFICE OF THE COUNTY MANAGER

5th Floor, New Courthouse • PO Box 1829 • Suite 512, • Fayetteville, North Carolina 28302-1829
(910) 678-7723 / (910) 678-7726 • Fax (910) 678-7717

MEMORANDUM FOR BOARD OF COMMISSIONERS AGENDA OF APRIL 20, 2009

TO: BOARD OF COUNTY COMMISSIONERS

FROM: JAMES E. MARTIN, COUNTY MANAGER 

DATE: MARCH 26, 2009

SUBJECT: PROPOSED ADDITIONS TO THE STATE SECONDARY ROAD SYSTEM

BACKGROUND

The North Carolina Department of Transportation has received petitions requesting the following streets be placed on the State Secondary Road System for maintenance (see attached):

Stone Creek Subdivision: Holloman Drive, Rockrose Drive
Lemuel Farm Road, Bexley Court

DOT has determined that the above streets are eligible for addition to the state system.

RECOMMENDATION

NCDOT recommends that the above named streets be added to the State Secondary Road System. County Management concurs.

PROPOSED ACTION

Approve the above listed streets for addition to the State Secondary Road System.

/ct

Attachments

Celebrating Our Past...Embracing Our Future



STATE OF NORTH CAROLINA
DEPARTMENT OF TRANSPORTATION

BEVERLY EAVES PERDUE
GOVERNOR

EUGENE A. CONTI, JR.
SECRETARY

April 1, 2009

Division Six - District Two
Cumberland County

Dr. Jeannette Council, Chairman
Cumberland County Board of Commissioners
Post Office Box 1829
Fayetteville, North Carolina 28302

Subject: Secondary Road Addition

Dear Dr. Council,

This is reference to a petition submitted to this office requesting street(s) in Cumberland County be placed on the State's Secondary Road System. Please be advised that these street(s) have been investigated and our findings are that the below listed street(s) are eligible for addition to the State System.

Stone Creek Subdivision

- Holloman Drive
- Rockrose Drive
- Lemuel Farm Road
- Bexley Court

It is our recommendation that the above named street(s) be placed on the State's Secondary Road System. If you and your Board concur in our recommendation, please submit a resolution to this office.

Sincerely,

A handwritten signature in cursive script that reads "David Plummer".

David Plummer
Transportation Tech. IV

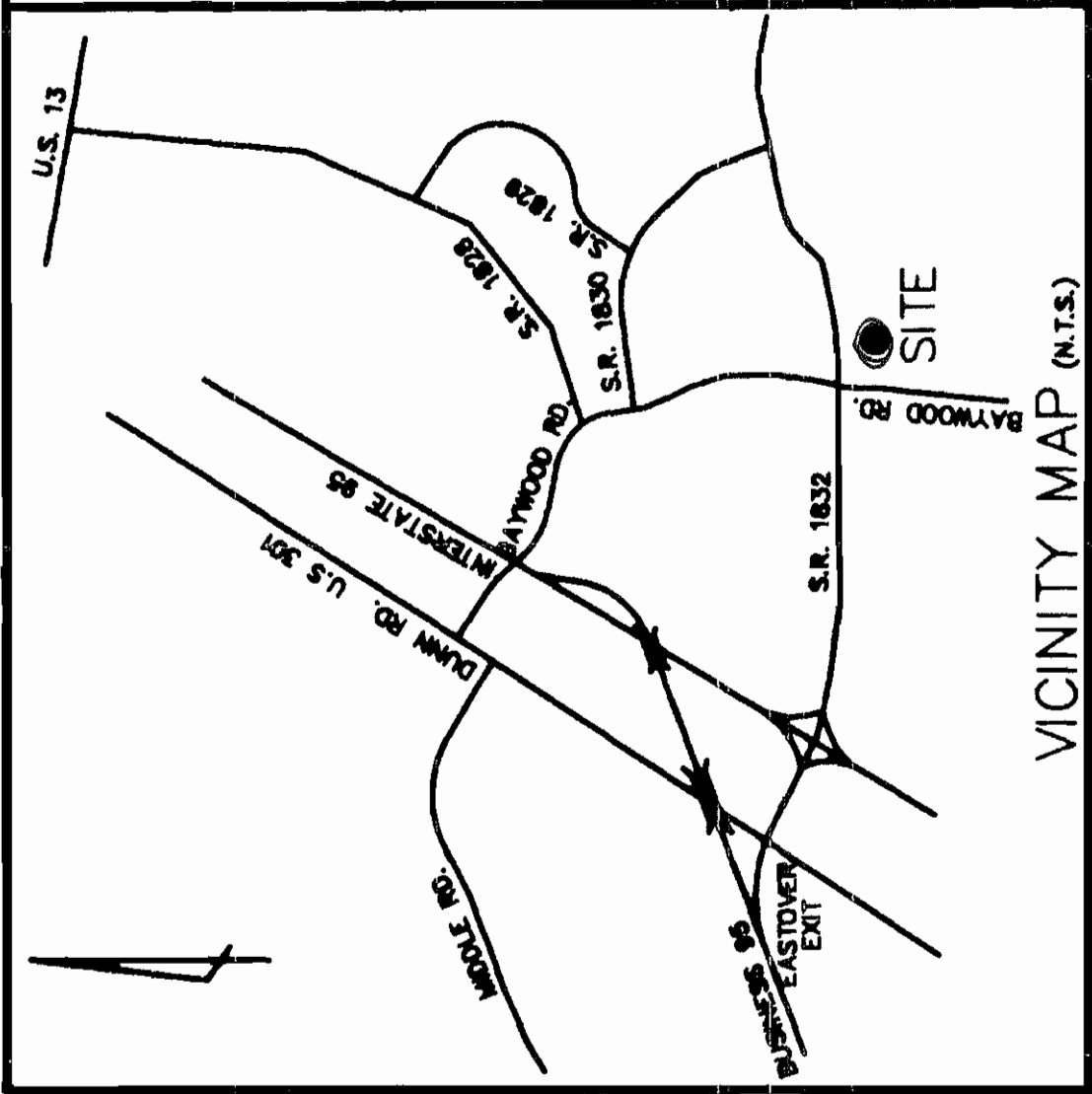

VICINITY MAP (N.T.S.)

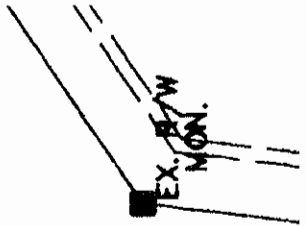



ITEM NO. 1C

OFFICE OF THE COUNTY ATTORNEY

Courthouse, 117 Dick Street – Suite 551 • P.O. Box 1829 • Fayetteville, North Carolina 28302-1829
(910) 678-7762 • Fax: (910) 678-7758

April 8, 2009

MEMORANDUM FOR BOARD OF COMMISSIONERS' APRIL 20, 2009 AGENDA:

TO: BOARD OF COMMISSIONERS

FROM: GRAINGER R. BARRETT, COUNTY ATTORNEY 

SUBJECT: APPROVAL OF SALE OF SURPLUS-COUNTY OWNED REAL
PROPERTY ACQUIRED BY TAX FORECLOSURE

822 VARSITY DRIVE LOT 12 BLOCK C ECCLES PARK
(LOCATED ON VARSITY DR. OFF ECCLES DR.)
PIN 0428-97-5847; CROSS CREEK TOWNSHIP

BACKGROUND: On or about March 5, 2007, the County acquired by tax foreclosure the above property. The amount currently owed on the foreclosure judgment including interest and cost for the property is \$12,462.61.

Alice P. Hinson has offered to purchase the County's interest in the property for **\$13,708.87** and has deposited \$13,708.87 in the Finance Office. The tax value of the property is \$48,500.00.

This property is surplus to the needs of the County and, according to N.C.G.S. 153A-176 and N.C.G.S. 105-376, the County has the authority to sell such property. Management has reviewed this offer and it is now being submitted for the Board to consider whether or not to accept Ms. Hinson's bid. The property has been advertised and this office has not received any upset bids. The bid period is now closed.

RECOMMENDATION AND PROPOSED ACTION: That the Board of Commissioners consider whether to accept the offer of Alice P. Hinson to purchase the above property for the sum of **\$13,708.87**, plus costs, and authorize the Chairman to execute a deed upon receipt of the balance of the purchase price.

GRB/hnw
Attachment

Celebrating Our Past... Embracing Our Future



Site Map

822 VARSITY DR
CROSS CREEK TOWNSHIP

50 0 50 100 Feet



THE COUNTY OF CUMBERLAND'S GIS DEPARTMENT ASSUMES NO LIABILITY FOR THIS PRODUCT. BUSINESS VISITORS EXPRESS OR IMPLIED WARRANTIES, THE ADOPTION THEREOF, RESPONSIBILITY FOR INTERPRETATION AND APPLICATION OF THIS PRODUCT LIES WITH THE USER.



ITEM NO. 15

OFFICE OF THE COUNTY ATTORNEY
Courthouse, 117 Dick Street – Suite 551 • P.O. Box 1829 • Fayetteville, North Carolina 28302-1829
(910) 678-7762 • Fax: (910) 678-7758

April 14, 2009

MEMORANDUM FOR BOARD OF COMMISSIONERS' MAY 4, 2009 AGENDA:

TO: BOARD OF COMMISSIONERS

FROM: GRAINGER R. BARRETT, COUNTY ATTORNEY *GRB*

SUBJECT: APPROVAL OF SALE OF SURPLUS-COUNTY OWNED REAL
PROPERTY ACQUIRED BY TAX FORECLOSURE

LOT 5 SPRINGDALE SUBDIVISION 2831 STRICKLAND BRIDGE RD
(LOCATED ON STRICKLAND BRIDGE RD)
PIN 9495-08-9444; SEVENTY-FIRST TOWNSHIP

BACKGROUND: On or about October 26, 2005, the County acquired by tax foreclosure the above property. The amount currently owed on the foreclosure judgment including interest and cost for the property is \$5,693.69.

Abner Cervera has offered to purchase the County's interest in the property for **\$5,693.69** and has deposited \$569.37 in the Finance Office. The tax value of the property is \$10,000.00.

This property is surplus to the needs of the County and, according to N.C.G.S. 153A-176 and N.C.G.S. 105-376, the County has the authority to sell such property. Management has reviewed this offer and it is now being submitted for the Board to consider whether or not to accept Mr. Cervera's bid. The property has been advertised and this office has not received any upset bids. The bid period is now closed.

RECOMMENDATION AND PROPOSED ACTION: That the Board of Commissioners consider whether to accept the offer of Abner Cervera to purchase the above property for the sum of **\$5,693.69**, plus costs, and authorize the Chairman to execute a deed upon receipt of the balance of the purchase price.

GRB/hnw
Attachment

Celebrating Our Past... Embracing Our Future

STRICKLAND BRIDGE RD

9495-08-9444-

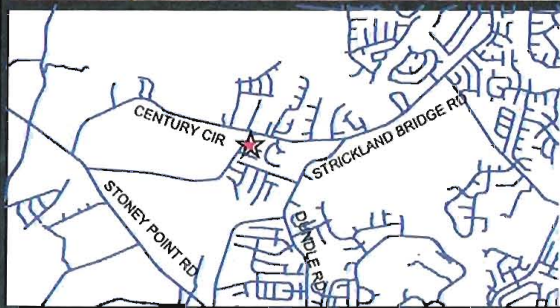

Site Map

2831 STRICKLAND BRIDGE RD
SEVENTY FIRST TOWNSHIP

50 0 50 Feet



THE COUNTY OF CUMBERLAND AND ITS GIS DEPARTMENT DISCLAIMS ACCOUNTABILITY FOR THIS PRODUCT AND MAKES NO WARRANTY EXPRESS OR IMPLIED CONCERNING THE ACCURACY THEREOF. RESPONSIBILITY FOR INTERPRETATION AND APPLICATION OF THIS PRODUCT LIES WITH THE USER.

ROBERT N. STANGER, P.E.
County Engineer



ITEM NO. 1E

SAM LUCAS
Engineering Technician II

WAYNE DUDLEY, CFM
Engineering Technician I

ENGINEERING DEPARTMENT

1 Historic Courthouse, 130 Gillespie Street • P.O. Box 1829 • Fayetteville, North Carolina 28302-1829
Telephone (910) 678-7636 • Fax (910) 678-7635

April 15, 2009

MEMORANDUM

TO: BOARD OF COUNTY COMMISSIONERS

FROM: ROBERT N. STANGER, COUNTY ENGINEER *BoC*

THROUGH: AMY H. CANNON, ASSISTANT COUNTY MANAGER

SUBJECT: APPROVAL OF INSURANCE CLAIM FOR GRAHAMS CONSTRUCTION
COURTHOUSE LOBBY ADDITION PROJECT

BACKGROUND

For past several months, the stairs at the Person Street entrance to the Courthouse have been out of service waiting on resolution of a dispute between Grahams Construction, the prime contractor, and his electrical subcontractor who failed to properly install the heat strips in the concrete stairs and landing. The heat strips have been repaired, however, the precast terrazzo stair treads and risers and the terrazzo landing have not been repaired to date. Grahams Construction forwarded a claim to their insurance company, Nautilus Insurance Group. As the owner of the project, Nautilus must settle the claim with the County. Attached is the letter from Nautilus stating they are prepared to settle the claim in the amount of \$35,638.00 which is the cost to cast, deliver and install the terrazzo stair treads and risers and repair the landing. Also attached is the release of claims required by Nautilus which has been reviewed by the County Attorney's Office for legal sufficiency.

Grahams Construction has contracted with Carolina Marble and Tile Company for the repair work and upon satisfactory installation and receipt of the insurance proceeds, the County will make payment to Grahams in the amount of \$35,638.00.

RECOMMENDATION/PROPOSED ACTION

The recommendation of the County Engineer, County Attorney, and management is to:

1. Accept the settlement from Nautilus Insurance Group in the amount of \$35,638.00 and execute the Release of All Claims.
2. Authorize payment to Grahams Construction, Inc., in the amount of \$35,638.00 upon satisfactory installation of the terrazzo stairs and landing and receipt of the insurance proceeds.

The proposed action by the board is to follow the staff recommendation.

Celebrating Our Past... Embracing Our Future



NAUTILUS INSURANCE GROUP®

Nautilus Insurance Company

Great Divide Insurance Company

April 07, 2009

Cumberland County Courthouse
Attn: Mr. Bob Stanger
130 Gillespie Street
Fayetteville, NC 28301

Via Email Only: rstanger@co.cumberland.nc.us

RE: Company: Nautilus Insurance Company
 Claim Number: **10041843**
 Our Insured: GRAHAMS CONSTRUCTION INC-LENNEA GRAHAM C/O
 Date of Loss: 09/04/2007

Dear Mr. Stanger:

On behalf of Nautilus Insurance Company, please find our release the amount of **\$ 35,638.00** as full and final settlement of the captioned matter, per our agreement.

Also, attached is the estimate from the terrazzo company for your review.

Please fill out and return the enclosed release as soon as possible. Upon receipt of the properly executed release we will issue payment to the addressee on this notice unless otherwise advised in the amount listed above.

Thank you for your cooperation and should you have any questions relating to this loss, please call me at (800) 842-8972 ext. 4062.

Sincerely,
Nautilus Insurance Company

Cynthia M. Cooks – MBA/CCLA
Examiner I

Encl. Release & Terrazzo Estimate

Carolina MARBLE and TILE Company

SINCE 1921

CONTRACTORS FOR TILE, MARBLE, TERRAZZO, MOSAICS AND DEX-O-TEX PRODUCTS
WINSTON-SALEM, N.C. 27103

* SHIPPING: 790 Megahertz Dr. WINSTON-SALEM, N.C. 27107 *

PHONE: 336-765-3050

FAX: 336-768-8716

THIS PROPOSAL, WHEN ACCEPTED, CONSTITUTES A CONTRACT BETWEEN PARTIES NAMED BELOW

March 12, 2009

BUILDING: Cumberland County Courthouse
LOCATION: North side porch

TO: Scott Graham

Phone: 910-770-0428

Fax: 910-655-3066

We propose to furnish and set, in accordance with drawings and specifications, conditions below and as specially designated here in, in building described above, as follows:

Labor & Material

- Demo the entire north side entrance
- Install an expansion strip
- Repour the terrazzo back (the color may vary because the other is now a year old)
- Work time to be determined
- Duration to complete 5 days

Steps:

- Supply and install 15 treads and risers on the north side
- All demo to be done by the G.C.
- Carolina Marble and Tile will not be responsible for any back charges or liquidated damages

Total \$35,638.00

Payment: 50% upfront and 50% seven days after the work is completed
Please sign the bottom and fax back. We will pickup our check when it is ready

THIS PROPOSAL IS EXPRESSLY CONDITIONED UPON THE USE OF THE
AGC/ASA/ASC STANDARD SUBCONTRACT FORM 1994-EDITION.

The undersigned accepts this proposal and all its terms and conditions as a binding contract subject only to the approval of the credit of the Buyer by the Seller which shall not be unreasonably withheld.

NORTH CAROLINA CONTRACTORS
LICBNSB NO. 23101

COMPANY: Grahams Construction Inc. CAROLINA MARBLE & TILE CO.

BY: [Signature]

TITLE: President

DATE: 4-1-09

By: [Signature]
Mark Smith

RELEASE OF ALL CLAIMS

CLAIM # 10041843

KNOW ALL MEN BY THESE PRESENTS:

That the Undersigned, being of lawful age, for the sole consideration of Thirty-Five thousand Six hundred Thirty-Eight dollars and 00./100 Dollars (\$ 35,638.00) to the undersigned in hand paid, receipt whereof is hereby acknowledged, do/does hereby and for my/our/its heirs, executors, administrators, successors and assigns release, acquit and forever discharge GRAHAMS CONSTRUCTION INC-LENNEA GRAHAM C/O and Nautilus Insurance Company and his, her, their, or its agents, servants, successors, heirs, executors, administrators and all other persons, firms, corporations, associations or partnerships of and from any and all claims, actions, causes of action, demands, rights, damages, costs, loss of service, expenses and compensation whatsoever, which the undersigned now has/have or which may hereafter accrue on account of or in any way growing out of any and all known and unknown, foreseen and unforeseen bodily and personal injuries and property damage and the consequences thereof resulting or to result from the accident, casualty or event which occurred on or about the 09/04/2007 at or near Fayetteville, NC.

It is understood and agreed that this settlement is the compromise of a doubtful and disputed claim, and that the payment made is not to be construed as an admission of liability on the part of the party or parties hereby released, and that said releases deny liability therefore and intend merely to avoid litigation and buy their peace.

The undersigned hereby declare(s) and represent(s) that the injuries sustained are or may be permanent and progressive and that recovery there from is uncertain and indefinite and in making this Release it is understood and agreed, the undersigned rely(ies) wholly upon the undersigned's judgment, belief and knowledge of the nature, extent, effect and duration of said injuries and liability therefore and is made without reliance upon any statement or representation of the party or parties hereby released or their representatives or by any physician or surgeon by them employed.

The undersigned further declare(s) and represent(s) that there may be unknown or unanticipated injuries resulting from the above stated accident, casualty or event and in making this Release it is understood and agreed that this Release is intended to include such injuries.

The undersigned further declare(s) and represent(s) that no promise, inducement or agreement not herein expressed has been made to the undersigned, and that this Release contains the entire agreement between the parties hereto, and that the terms of this Release are contractual and not a mere recital.

This Release expressly reserves all rights of the person, or persons, on whose behalf the payment is made and the rights of all persons in privity or connected with them, and reserves to them their right to pursue their legal remedies, if any, including but not limited to claims for contribution, property damage and personal injury against the undersigned or those in privity or connected with the undersigned.

Any person who knowingly and with intent to defraud any insurance company or other person files a statement of claim containing any materially false information or conceals, for the purpose of misleading, information concerning any fact material thereto commits a fraudulent insurance act, which is a crime.

THE UNDERSIGNED HAS READ THE FOREGOING RELEASE AND FULLY UNDERSTANDS IT.

Signed, sealed and delivered this _____ day of _____, 2009.

CAUTION: READ BEFORE SIGNING BELOW ↓

Printed Name

Signature

Printed Name

Signature

STATE OF _____

} SS.

COUNTY OF _____

On the _____ day of _____, 2009, before me personally appeared _____

to me known to be the person(s) named herein and who executed the foregoing Release and _____ acknowledged to

me that _____ voluntarily executed the same.

My term expires _____, 20____.

Notary Public

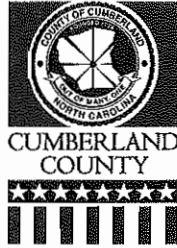

ITEM NO. 1F

COMMUNITY DEVELOPMENT
245 Person Street, 2nd Floor - P.O. Box 1829 • Fayetteville, North Carolina 28302-1829
(910) 323-6112 • Fax: (910) 323-6114

MEMORANDUM FOR BOARD OF COMMISSIONERS AGENDA
APRIL 20, 2009

TO: BOARD OF COUNTY COMMISSIONERS

THRU: JUANITA PILGRIM, DEPUTY COUNTY MANAGER

FROM: THANENA S. WILSON, COMMUNITY DEVELOPMENT DIRECTOR *T.S. Wilson*

DATE: April 9, 2009

SUBJECT: COMMUNITY DEVELOPMENT AFFIRMATIVE MARKETING POLICY AND PROCEDURES

BACKGROUND

Under the HOME Program, each participating jurisdiction must adopt affirmative marketing procedures and requirements for rental and homebuyer projects containing five or more HOME-assisted housing units. Affirmative marketing steps consist of actions to provide information and otherwise attract eligible persons in the targeted housing market to the available housing without regard to race, color, national origin, sex, religion, familial status, or disability. The following document (Attachment A) is a draft of Cumberland County Community Development's updated Affirmative Marketing Policy and Procedures that will be adhered to during our endeavor to provide affordable housing within Cumberland County. This draft also contains specific references to practices that are allowed or disallowed according HUD's policy guidelines under the Code of Federal Regulations.

Please note that the original Affirmative Marketing Policy and Fair Housing Marketing Plan was approved on April 19, 2004. The attached document is an update of the original policy.

RECOMMENDATION AND PROPOSED ACTION

Community Development requests that the Board of County Commissioners approve the attached draft so that it is incorporated as part of policy and procedures for the Cumberland County HOME Program.

Attachment A – Affirmative Marketing Policy and Procedures
Celebrating Our Past... Embracing Our Future

**Cumberland County Community Development
AFFIRMATIVE MARKETING POLICY
(EQUAL HOUSING OPPORTUNITY)**

STATEMENT OF POLICY

This Affirmative Marketing Policy ("the Policy") is developed for use in Home Investment Partnership Act ("HOME") funded projects in accordance with the HOME Program regulations including, but not limited to, 24 CFR 92.351, of the U.S. Department of Housing and Urban Development ("HUD"). The Policy is a commitment of the elected body, Cumberland County Community Development (CCCD) staff, and the HOME-funded participant ("Funding Recipient") to affirmatively further fair housing choice. The Funding Recipient shares responsibility with Cumberland County to inform the public about Federal Fair Housing laws which require solicitation of eligible persons without regard to race, color, national origin, sex, religion, familial status, or disability for participation in Cumberland County's federally funded housing programs. These affirmative marketing efforts also include evaluation of their effectiveness. This Affirmative Marketing Policy is documented and maintained in CCCD files, and shall be included by reference in all HOME project proposals, agreements and case files.

PURPOSE

In accordance with the regulations of the HOME Program and in furthering Cumberland County's commitment to non-discrimination and equal housing opportunity, the County has established procedures to affirmatively market units constructed or rehabilitated under the HOME Program. The purpose of Cumberland County's Affirmative Marketing Policy is to assure that individuals who normally might not apply for available housing units because they are socially and/or economically disadvantaged:

- be informed of available units;
- be encouraged to apply;
- have an equal opportunity to rent or purchase available units.

I. *METHODS THE COUNTY WILL USE TO INFORM THE PUBLIC, POTENTIAL TENANTS, AND POTENTIAL OWNERS ABOUT FEDERAL FAIR HOUSING LAWS AND AFFIRMATIVE MARKETING POLICIES AND PROCEDURES*

- A. CCCD shall be responsible for implementing the Affirmative Marketing Policy and evaluating its effectiveness as required by the HOME Program.
- B. CCCD shall inform the community about its Affirmative Marketing Policy through periodic updates with the County's elected officials as well as through training workshops with its HOME applicants.
- C. All graphic presentations by CCCD concerning the HOME Program shall display the HUD Equal Housing Opportunity logo and/or slogan.

- D. At the time of HOME funding, CCCD shall provide the Funding Recipient with copies of the "Fair Housing It's the Law" brochure, as produced by HUD; as well as the "Fair Housing Educational Handbook" produced by the Fayetteville-Cumberland County Human Relations Department, or a similar document. The Funding Recipient shall provide initial homeowners, tenants, and rental property owners with copies of each document.
- E. CCCD will continue its practice of providing general information to persons contacting the department with questions regarding Affirmative Marketing and assisted housing. Persons contacting the department or Funding Recipients with questions regarding Fair Housing, tenant's rights, and correction of substandard conditions in tenant-occupied dwellings will be referred to the Fayetteville-Cumberland County Human Relations Department.
- F. CCCD's Fair Housing Specialist will maintain a distribution list of housing and service providers for targeted populations to include, but not limited to: public housing residents, homeless individuals and families, veterans, elderly, disabled, etc. for fair housing marketing and outreach efforts.

II. REQUIREMENTS AND PRACTICES EACH FUNDING RECIPIENT OF A HOUSING PROJECT USING HOME PROGRAM FUNDS MUST ADHERE TO IN ORDER TO CARRY OUT THE COUNTY'S AFFIRMATIVE MARKETING POLICY

It is Cumberland County's Policy to require that each Funding Recipient of a housing project completed or partially completed with HOME Program funds:

- A. Incorporate the Equal Housing Opportunity statement and/or logo in its correspondence that relates to housing produced through the HOME Program.
- B. Ensure that the Equal Housing Opportunity sign is placed in a conspicuous location that is easily visible to potential applicants and current tenants.
- C. Periodically purchase advertisements in minority newspapers notifying the public of vacant units in advance of selecting a buyer or tenant without holding units off the market. All advertisements must contain an Equal Housing Opportunity statement and/or logo.
- D. Notify the Fayetteville Metropolitan Housing Authority when vacant units are available for purchase or rent.
- E. All advertisements, brochures, and other written materials must be published in multiple languages, in order to reach non-English-speaking audiences.

F. Notify Fayetteville-Cumberland County Human Relations Department when vacant units are available for purchase or rent.

Funding Recipients are also encouraged to participate in the Fayetteville / Cumberland County Continuum of Care Planning Council.

III. PROCEDURES TO BE USED BY FUNDING RECIPIENTS TO INFORM AND SOLICIT APPLICATIONS FROM PERSONS IN THE HOUSING MARKET AREA WHO ARE NOT LIKELY TO APPLY FOR HOUSING WITHOUT SPECIAL OUTREACH

In order to solicit applications from persons in the housing market area who are not likely to apply for housing under the HOME Program without special outreach, each Funding Recipient shall send notices of vacant units, or units that will become vacant within 30 days to an approved distribution list maintained by CCCD's Fair Housing Specialist. These efforts shall remain in force for the required period of affordability as referenced in the applicable HOME Agreement. The distribution list will include, but not be limited to, the following:

- The Fayetteville Metropolitan Housing Authority;
- Department of Social Services,
- Veterans Administration Office; and
- Other agencies where socially and economically disadvantaged individuals are receiving services.

IV. RECORDS THAT WILL BE KEPT DESCRIBING ACTIONS TAKEN BY CUMBERLAND COUNTY AND FUNDING RECIPIENTS TO AFFIRMATIVELY MARKET UNITS AND RECORDS TO ASSESS ACTIONS

A. CCCD will keep the following records:

1. Copies of all meeting agendas and minutes of the Cumberland County Board of Commissioners pertaining to this Policy, and all agendas and training materials of any HOME training workshop pertaining to this Policy.
2. Copies of correspondence, agreements, reports and any homebuyer or tenant surveys conducted before and after new construction or rehabilitation of HOME-funded units.

B. CCCD shall also request Funding Recipients assisted under the HOME program to maintain the following records:

1. Copies of advertisements, brochures, surveys, and letters to community contacts;
2. Special outreach activities undertaken to attract groups least likely to apply for HOME-assisted housing without special outreach;

3. Documentation of how all applications were processed upon completion, specifically documenting race, ethnicity, age, and/or disability.
4. Certification that all rental/sales staff is trained on Fair Housing laws on an annual basis.

V. DESCRIPTION OF HOW CUMBERLAND COUNTY WILL ASSESS THE SUCCESS OF AFFIRMATIVE MARKETING ACTIONS, AND WHAT CORRECTIVE ACTIONS WILL BE TAKEN

- A. CCCD will assess the effectiveness of its Affirmative Marketing Policy on an annual basis by August 31st and will include a summary of the “good faith efforts” taken by CCCD and by HOME Funding Recipients in the Consolidated Annual Performance and Evaluation Report (CAPER).
- B. CCCD will compare the information compiled in the manner described under Section IV above and evaluate the degree to which statutory and policy objectives were met. If the required steps were taken, CCCD will determine that good faith efforts have, in fact, been made.
- C. To determine results, CCCD may examine whether or not specific groups in Cumberland County applied for or became tenants or owners of HOME-assisted units that were affirmatively marketed. If CCCD finds that specific groups are represented, particularly Hispanics, African Americans, Asian/Pacific Islanders, American Indians, persons with disabilities and women, CCCD will assume that the Affirmative Marketing procedures were effective. If one or more groups are not represented within the context of existing neighborhood composition, CCCD will review its procedures to determine what changes, if any, might be made to make the Affirmative Marketing efforts more effective.
- D. CCCD will take corrective action if it is determined that a Funding Recipient has failed to carry out Affirmative Marketing efforts as required. If a Funding Recipient continues to neglect responsibilities made incumbent by the terms of the HOME Agreement, the County will consider taking one or both of the following actions:
 1. Declare the Funding Recipient disqualified from any further assistance made available under the HOME Program.

2. Notify the Funding Recipient that there is a violation of the terms of the HOME Agreement and that the County may exercise its right to require immediate repayment of the grant or loan.
- E. The Funding Recipient shall be given a reasonable time period to bring their program into compliance. CCCD shall not proceed with any adverse corrective action without allowing time and effort by staff to counsel the Funding Recipient in accordance with the terms of the HOME Agreement.

VI. *MINORITY OUTREACH*

Cumberland County is committed to a minority outreach program that ensures the inclusion, to the maximum extent possible, of minorities and women, and entities owned by minorities and women. This will include without limitation: real estate firms, construction firms, appraisal firms, management firms, financial institutions, investment banking firms, underwriters, accountants, and providers of legal services, in all contracts entered into by Cumberland County with such persons or entities, public and private, in order to facilitate the activities of Cumberland County to provide affordable housing. This is evidenced by Cumberland County's Policy and Procedures for Affirmative Contracting with Minority and Women Business Enterprises as approved by the Cumberland County Board of Commissioners.



ITEM NO. 16

COUNTY of CUMBERLAND

James E. Martin
County Manager

Cliff Spiller
Assistant County Manager

Juanita Pilgrim
Deputy County Manager

Office of the County Manager

Amy H. Cannon
Assistant County Manager

MEMORANDUM FOR BOARD OF COMMISSIONERS AGENDA OF APRIL 20, 2009

TO: BOARD OF COUNTY COMMISSIONERS

FROM: JAMES E. MARTIN, COUNTY MANAGER

DATE: APRIL 15, 2009

SUBJECT: APPROVAL OF TRANSFER OF 10 MTS-2000 RADIOS FROM CUMBERLAND COUNTY SHERIFF'S OFFICE TO THE BETHANY RURAL FIRE DEPARTMENT, INC.

BACKGROUND:

The Cumberland County Sheriff's Office is requesting that ten MTS-2000 radios be transferred to the Bethany Rural Fire Department, Inc.

The Bethany Rural Fire Department, Inc. has expressed that they are in desperate need of the additional radios and due to available funds they are unable to purchase additional units at this time.

Sheriff, Earl Butler, has approved the transfer.

RECOMMENDATION/PROPOSED ACTION:

Staff and Management recommend that the ten MTS-2000 radios be transferred from the Cumberland County Sheriff's Office to the Bethany Fire Department, Inc.

JM/cp

JM041509-1





EARL R. BUTLER, SHERIFF
CUMBERLAND COUNTY SHERIFF'S OFFICE



An Internationally Accredited Law Enforcement Agency

To: Amy Cannon
Assistant County Manager
Cumberland County

Thru: Major James Black 
Services Commander
Cumberland County Sheriff's Office
Fayetteville, NC 28301

From: Al Lozano 
Supply Control Officer
131 Dick Street
Fayetteville, NC 28301

Date: April 3, 2009

Re: Transfer of MTS-2000 Walkie Talkies

We are requesting that the MTS-2000 radios be transferred to the Bethany Fire Department, Inc.

The Cumberland County Sheriff, Earl Butler, has approved the transfer.

Thank you very much for your cooperation.

CC: Dennis Owens - Surplus Property Report

2140 Wade Stedman Road
Stedman, NC 28391



Approved
by Sheriff
3/30/09
Bus. Phone (910) 483-1581
Fax (910) 483-4397
e-mail: bfd12@nc.rr.com
[Signature]

March 25, 2009

Cumberland County Sheriff's Department

To Whom It May Concern:

We understand that the Sheriff's Department is excessing a supply of 800 MHz radios (WT's). We are very interested in obtaining some of the units when available.

Our station is in desperate need of additional radios; however, due to low budget funding, we are not able to purchase additional units at this time. The units would be used only by the Bethany Rural Fire Department & we will be most grateful if you will consider our request to receive ten (10) radios.

Sincerely,

BETHANY RURAL FIRE DEPARTMENT

J F Hall
Chief

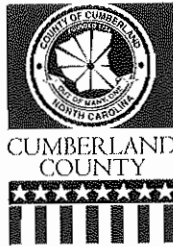

ITEM NO. 14

OFFICE OF THE COUNTY ATTORNEY

Courthouse, 117 Dick Street – Suite 551 • P.O. Box 1829 • Fayetteville, North Carolina 28302-1829
(910) 678-7762 • Fax: (910) 678-7758

April 15, 2009

MEMORANDUM FOR BOARD OF COMMISSIONERS' APRIL 20, 2009 AGENDA

TO: BOARD OF COMMISSIONERS

FROM: GRAINGER BARRETT, COUNTY ATTORNEY *GB*

SUBJECT: APPROVAL OF DECLINING RIGHT OF FIRST REFUSAL FOR BOARD OF EDUCATION SURPLUS PROPERTY, EASTOVER CIVIC CENTER, PROPOSED TO BE CONVEYED TO TOWN OF EASTOVER

BACKGROUND: The enclosed correspondence indicates that the Board of Education proposes to declare property owned by it at the corner of School and Middle Roads in the Town of Eastover, the Eastover Civic Center, to be surplus and to convey the parcel to the Town of Eastover to be used as its Town Hall. By statute, the Board of Education must first provide to the County a right of first refusal to acquire property declared surplus by a board of education. To facilitate the conveyance of the property to the Town of Eastover as proposed by the Board of Education, it would be appropriate for the Board of Commissioners to decline to exercise that right of first refusal.

RECOMMENDATION: Approve declining right of first refusal to acquire property declared surplus by the Board of Education, PIN # 0648-29-9123.

Attch.

Celebrating Our Past...Embracing Our Future



Cumberland County Schools

P.O. Box 2357

Fayetteville, North Carolina 28302

910-678-2300

GREG WEST, CHAIR
CARRIE SUTTON, VICE CHAIR
ALICIA S. CHISOLM
KIMBERLY P. FISHER
MACKY HALL

LARRY L. LANCASTER
JAMES A. MCLAUCHLIN
MARY EMILY ROYAL
MAC WILLIAMS

April 15, 2009

James Martin, County Manager
County of Cumberland
P. O. Drawer 1829
Fayetteville, NC 28302

Re: Surplus Real Property

Dear James,

The Cumberland County Board of Education has declared 1.25+/- acres of real property located on the corner of School Road and Middle Road in Eastover surplus property (Parcel ID# 0468-29-9123). As per North Carolina General Statutes, the Board of Education is offering the property to the County for acquisition. Provided the County declines the acquisition, the Board is prepared to sell the property to the Town of Eastover. The property contains a building constructed and maintained by the Eastover Civic Club. The Town of Eastover desires to purchase the property and convert the building to a town hall.

Please present this matter to the County Commissioners at their next meeting for consideration. Your assistance is appreciated.

Sincerely,

Tim H. Kinlaw, Interim Superintendent
Cumberland County Schools



ITEM NO. 11

OFFICE OF THE COUNTY ATTORNEY

Courthouse, 117 Dick Street – Suite 551 • P.O. Box 1829 • Fayetteville, North Carolina 28302-1829
(910) 678-7762 • Fax: (910) 678-7758

April 14, 2009

MEMORANDUM FOR BOARD OF COMMISSIONERS' APRIL 20, 2009 AGENDA

TO: BOARD OF COUNTY COMMISSIONERS

FROM: HARVEY W. RAYNOR III, DEPUTY COUNTY ATTORNEY *HW Raynor III*

THRU: GRAINGER R. BARRETT, COUNTY ATTORNEY *GRB*

SUBJECT: SCHEDULE HEARING ON TAXPAYERS' REQUEST FOR A REFUND FOR OVERPAYMENT OF EXCISE TAX PURSUANT TO NCGS 105-228.37

BACKGROUND:

Attorneys F. Stuart Clarke and Joel S. Jenkins, Jr. have filed written request through the Register of Deeds office to be refunded the County's portion of excises taxes paid when deeds were inadvertently recorded in Cumberland County that should have been recorded only in Robeson County or Hoke County. The excise tax paid was \$436.00 and the County's portion was \$218.00 in Mr. Clarke's matter and \$170.00 and \$85.00 in Mr. Jenkins' matter.

NCGS 105-228.37 requires upon request of a refund of an excise tax that a public hearing be held prior to the Board taking any action.

RECOMMENDATION / PROPOSED ACTION:

Schedule hearings required by the statute at the May 4, 2009 Board meeting and then consider whether to refund the County portion, \$218.00 and \$85.00, respectively. Deputy County Attorney, Harvey Raynor, will appear as the only witness.

Celebrating Our Past... Embracing Our Future

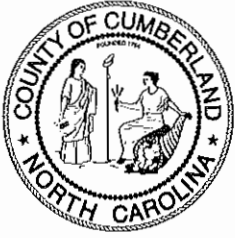

COUNTY of CUMBERLAND

Office of the Register of Deeds

J. Lee Warren, Jr.
Register of Deeds

Pamela H. Gore
Sr. Assistant Register of Deeds

Diana H. Fisher
Assistant Register of Deeds

Michelle W. Mackey
Assistant Register of Deeds

Lisa A. Scales
Assistant Register of Deeds

Jacqueline Thomas
Administrative Deputy

MEMORANDUM

TO: HARVEY RAYNOR
ASST. COUNTY ATTORNEY

FROM: PAM GORE 
SR. ASST. REGISTER OF DEEDS

REF: REIMBURSEMENT OF EXCISE TAX

DATE: APRIL 7, 2009

Attached please find two requests for reimbursement of Excise Tax in which case the deeds were erroneously recorded in Cumberland County.

The first request submitted by Joel S. Jenkins, Jr., Attorney with revenue paid in the amount of \$170.00 in Book 8014 Page 1 should have been recorded in Hoke County. The second request in Book 7589 Page 151 is in the amount of \$436.00 by F. Stuart Clarke, Attorney and should have been recorded in Robeson County.

Since one half of the amounts of these revenues has been sent to the state, we are requesting approval from the Board of Commissioners for each of the above in the amounts of \$85.00 and \$218.00, which reflect one half of the amount. A copy of each deed is also attached.

Upon approval, I will submit a request to accounts payable to have these checks issued.

Thanks for your assistance.

Thorp, Clarke, Neville & Kirby, P.A.

Attorneys at Law

Herbert H. Thorp (1932-1996)
F. Stuart Clarke
J. Thomas Neville
Jennifer L. Kirby

150 N. McPherson Church Rd., Ste. B • Fayetteville, NC 28303
Mailing Address: Post Office Box 670 • Fayetteville, NC 28302-0670
Phone (910) 323-4111 and Fax (910) 483-1247

Surf City Office:
13775 Ocean Hwy 50
Suite 107
Surf City, NC 28445
Phone: (910) 329-4400
Fax: (910) 329-1001

March 23, 2009

Honorable J. Lee Warren, Jr.
County of Cumberland
Office of the Register of Deeds

Hand Delivered

Re: Refund of revenue

Dear Mr. Warren:

It has recently come to my attention that my office inadvertently recorded a Hoke County property in the Cumberland County Register of Deeds office. Attached find a copy of said deed recorded on May 16, 2007 in Book 7589, Page 151 of the Cumberland County Registry. We have recently recorded the documents in Hoke County and request Cumberland County refund the \$436.00 revenue which has now been paid to the Hoke County office. If you have any questions, please feel free to contact me.

Very truly yours,

Thorp, Clarke, Neville & Kirby, PA



F. Stuart Clarke

FSC/vs
Enclosure

Other Fayetteville Offices:

5509 Yadkin Road, Fayetteville, NC, 28303, Phone (910) 826-7602, Fax (910) 826-7604
3620 Legion Road, Hope Mills, NC 28348, Phone (910) 429-2935, Fax (910) 429-2965

Law Office of
Joel S. Jenkins, Jr.

Attorney at Law, P.A.

2919 Breezewood Avenue, Third Floor
Fayetteville, NC 28303

Mailing Address:
P.O. Drawer 53515
Fayetteville, NC 28305

Telephone: (910) 222-4000
Facsimile: (910) 323-5505
E-mail: Lawjenkins@aol.com

March 18, 2009

**Cumberland County Register of Deeds
PO Box 2039
Fayetteville, NC 28302**

Re: Revenue Refund

Dear Ladies/Gentlemen:

Attached please find a NC General Warranty Deed which was recorded November 3, 2008 in Book 8014 page 1. This deed was recorded in Cumberland County in error; it should have been recorded in Robeson County. When we recorded this deed, \$170.00 revenue was charged on attached deed and we are asking that the revenue be refunded.

Please issue a check in the amount of \$170.00 payable to Single Source Real Estate Services, Inc. to the attention of Barbara Lotierzo.

Thank you for your immediate attention to this matter.

Sincerely,

Joel S. Jenkins, Jr.

Encls.



ITEM NO. 15

OFFICE OF THE COUNTY ATTORNEY
Courthouse, 117 Dick Street – Suite 551 • P.O. Box 1829 • Fayetteville, North Carolina 28302-1829
(910) 678-7762 • Fax: (910) 678-7758

April 14, 2009

MEMORANDUM FOR BOARD OF COMMISSIONERS' APRIL 20, 2009 AGENDA

TO: BOARD OF COUNTY COMMISSIONERS

FROM: HARVEY W. RAYNOR III, DEPUTY COUNTY ATTORNEY *HW R III*

THRU: GRAINGER R. BARRETT, COUNTY ATTORNEY *GRB*

SUBJECT: APPROVAL OF PWC REQUEST FOR GRANT OF A WATER AND SEWER EASEMENT AT WESTERN ELEMENTARY AND LIBRARY SITE.

BACKGROUND:

PWC has a policy of requiring landowners to grant an easement to the City of Fayetteville for the installation, maintenance and improvement of any utility service provided by PWC to the landowner's property. PWC is providing water and sewer service to the above referenced site.

RECOMMENDATION / PROPOSED ACTION:

Pass the attached resolution granting the easements subject to Legal's approval of the form and language of the easement deed.

Celebrating Our Past... Embracing Our Future

**A RESOLUTION OF THE CUMBERLAND COUNTY BOARD OF COMMISSIONERS
GRANTING WATER & SANITARY SEWER EASEMENTS TO THE CITY OF
FAYETTEVILLE FOR WESTERN ELEMENTARY SCHOOL AND LIBRARY SITE**

WHEREAS, the PWC has agreed to supply water & sanitary sewer service to the Western Elementary and Library site; and

WHEREAS, PWC has a policy of supplying such services to a property only after the landowner has granted the City of Fayetteville, PWC's owner, an easement for the services to be supplied; and

WHEREAS, PWC has requested the County as landowner of the site grant such easements; and

WHEREAS, the Board of Commissioners approves granting the easements as requested;

NOW, THEREFORE, BE IT RESOLVED by the Cumberland County Board of Commissioners that it approves conveyance of the water and sanitary sewer easements described in the PWC Drawing No. EWS – 14184; Pin No. 9485-07-48-3897; “Western Elementary School – Public Library and Information Center” which lie within the utility easements as shown on plats recorded in Plat Book 123 at pages 11 & 12 and Plat Book 124 at pages 16 & 17, all in the Cumberland County Registry; and

BE IT FURTHER RESOLVED, that the Board of Commissioners authorizes the Chair of the Board to execute and the Clerk to the Board to acknowledge easement deed satisfactory to the County Attorney conveying said water & sanitary sewer easements to the City of Fayetteville.

This the 20th day of April, 2009.

JEANNETTE M. COUNCIL, Chair,
Board of Commissioners

ATTEST:

MARSHA FOGLE, Clerk
Board of Commissioners



ITEM NO. 1K

OFFICE OF THE COUNTY ATTORNEY

Courthouse, 117 Dick Street – Suite 551 • P.O. Box 1829 • Fayetteville, North Carolina 28302-1829
(910) 678-7762 • Fax: (910) 678-7758

April 2, 2009

MEMORANDUM FOR BOARD OF COMMISSIONERS' AGENDA OF APRIL 20, 2009

TO: BOARD OF COMMISSIONERS

FROM: GRAINGER R. BARRETT, COUNTY ATTORNEY 

**SUBJECT: APPROVAL OF RESOLUTION OF INTENT TO EXCHANGE
WITH SHOOTERS SUPPLY CERTAIN PERSONAL PROPERTY
DECLARED SURPLUS BY SHERIFF**

BACKGROUND: Sheriff Butler requests that the Board of Commissioners authorize his Office to approve an exchange of certain personal property declared surplus by his Office with Shooters Supply, Fayetteville, N.C. for certain specialized equipment, as noted in the attached. The estimated value of the property changing hands is \$5,440.00. Please refer to the enclosed memorandum from Sheriff Butler dated March 26, 2009. G.S. 160A-271 authorizes the Board to approve an exchange of property provided it publishes notice.

RECOMMENDATION: Approve resolution of intent to exchange personal property with Shooters Supply, as listed in the enclosed memorandum from Sheriff Butler and direct staff to publish notice of intent to exchange property pursuant to G.S. 160A-271. The Board may take final action approving the exchange at its next meeting, on May 4, 2009.

Encl.

Celebrating Our Past...Embracing Our Future

**CUMBERLAND COUNTY BOARD OF COMMISSIONERS
RESOLUTION OF INTENT TO EXCHANGE CERTAIN PERSONAL
PROPERTY WITH
SHOOTERS SUPPLY, PURSUANT TO G.S. 160A-271**

BE IT RESOLVED that at its next regular meeting to be held at the Cumberland County Courthouse on May 4, 2009, at 9:00 a.m., the Cumberland County Board of Commissioners intends to adopt a resolution authorizing the exchange of certain personal property declared surplus by the Cumberland County Sheriff's Office for specialized equipment to be exchanged with Shooters Supply, Fayetteville, N.C., as more particularly described in the memorandum from Sheriff Earl R. Butler included in the agenda of this meeting.

BE IT FURTHER RESOLVED that the Clerk to the Board shall advertise notice of this intent in conformance with G.S. 160A-271.

Adopted at a regular meeting held April 20, 2009.

Jeannette M. Council, Chairman
Cumberland County Board of Commissioners

Marsha Fogle
Clerk to the Board



**EARL R. BUTLER, SHERIFF
CUMBERLAND COUNTY SHERIFF'S OFFICE**



An Internationally Accredited Law Enforcement Agency

To: James Martin County Manager

Fr: Earl R. Butler Sheriff

APR - 1 2009

Re: Weapons Trade Request

Dt: March 26, 2009

It is our desire to trade weapons that are currently in our inventory that are not being utilized, in order to upgrade and modernize the weapons being used by our Narcotics Unit.

We have proposed a tentative trade agreement with Shooters Supply 5103 Bragg Blvd. Fayetteville, NC to do an even trade on specialized equipment/weapons with no money exchanged.

These trade-ins are beneficial to the Sheriff's Office, allowing us to upgrade weapons as well as dispose of weapons which are either outdated, or in need of repair and are not being used.

Thanks in advance for your assistance in fulfilling this request. If you have any questions, please do not hesitate to contact this office.

Attachment(s): Shooters Supply Quote
CCSO Weapons Trade List

Cf:
County Legal



5103 Bragg Blvd.
Fayetteville, NC 28303
910.860.3700 phone
910.860.4719 fax
www.shooters-supply.net
davidm@shooters-supply.net

March 16, 2009

Cumberland County Sheriff's Dept.
131 Dick St.
Fayetteville, NC 28301

Attn: John Sawyer

Shooters Supply, 5103 Bragg Blvd, Fayetteville, NC 28303 agrees to provide the Cumberland County Sheriff's Dept. with a quantity of ten (10) Glock model 30 .45ACP semi-auto duty pistols with nite sites in exchange for the twenty-four (24) firearms on the "Weapons Trade List 2009" as provided by Lt. Sawyer.

If you have any questions please contact **Dave Morketter** at (910)860-3700 or davidm@shooters-supply.net

Thank you.

Weapons Trade List 2009

Handguns

<u>Make</u>	<u>Model</u>	<u>Serial Number</u>	<u>Trade Value</u>
Beretta	92FS	BER370032Z	\$283
Beretta	92FS	BER095004Z	\$283
Desert Eagle	357 Magnum	50104	\$600
Ruger	P-90	661-13576	\$216
Sig-Sauer	SP2009	SP0029957	\$360
Taurus	44 Magnum	V1976617	\$350
Taurus	44 Special	LA573071	\$102
Taurus	38 Special	1G94403	\$97

Rifles/Shotguns

Belgian	Double Barrel	12743	\$100
Chinese	SKS/ with 37mm	24227235	\$250
EAA Corp	Double Barrel	IZH-43	\$250
Henry	22 Cal. Rifle	335680H	\$250
Ithica	12 GA.	M870024876	\$200
Mossberg	500-A 12 Ga.	K365815	\$150
Mossberg	590 12 Ga.	R426095	\$150
Mossberg	183 DG 410	327297	(Damaged) \$50
Maverick	Mod-88 12 Ga.	MV09054J	\$150
Maverick	Mod-88 12 Ga.	MV84824E	\$150
National Ordnance	M-1 Carbine	5243	\$400
New England	20 Ga.	NH464902	\$100
Remington	700	B6684599	\$275
Remington	870 12 Ga.	D861345M	\$225
Romainian	AK-47	KE2769-79	\$300
Ultra Cell	12 Ga.	0301923	\$150

Total \$5,441



5103 Bragg Blvd.
Fayetteville, NC 28303
910.860.3700 phone
910.860.4719 fax

www.shooters-supply.net
davidm@shooters-supply.net

2-17-09

LT Sawyer

1. Proposed by LT
Ray Narcotics

2. Is this a good
idea?

Howard

Feb 16, 2009

PRICE QUOTE

Cumberland County Sheriff's Dept.
131 Dick St.
Fayetteville, NC 28301

To whom it may concern:

Shooters Supply, 5103 Bragg Blvd., Fayetteville, NC 28303 agrees to trade quantity 9 each New In Box Glock model 30 .45acp pistols with nite sites and 2 mags per gun to the CCSD in exchange for quantity 12 each Used Glock 19 9mm pistols with nite sites and 2 mags each.

The exchange of items will take place at time of delivery of the New Glock 30 pistols, approximately 4 weeks from date of order.

Questions? Please contact **David Morketter** at (910)860-3700 or davidm@shooters-supply.net

[Handwritten signatures and initials]



QUOTATION

Cost .
If Buy New

HL

Quote Date: 16-Feb-09
Quote Title: CCSD G30NS
Contact: David Morketter

Customer Name: CCSD
Address:

Phone Number:
Fax Number:
Email Address:

Quantity	Item Number / Item Description	Unit Price	Line Total
1 ⁰	Glock mod 30 pistol .45acp w nite sites	\$649.99	\$5,849.97 6,499.90
9	NC sales tax @ 7%	\$45.50	\$409.50 455.00
GRAND TOTAL:			\$6,259.47 6,954.90

Comments:

Delivery Time: Appx 4-6 weeks
Payment Terms:
Freight Terms:
Validity Date:
Quoted By:

Price Approved By:

Thank you for your interest and trust in quality products from Shooter's Supply.

5103 Braqq Blvd. Fayetteville, NC 28303
Telephone Number: 910-860-3700
Fax Number: 910-860-4719
Email: davidm@shooters-supply.net



ITEM NO. 1L

OFFICE OF THE COUNTY ATTORNEY

Courthouse, 117 Dick Street – Suite 551 • P.O. Box 1829 • Fayetteville, North Carolina 28302-1829
(910) 678-7762 • Fax: (910) 678-7758

April 15, 2009

MEMORANDUM FOR BOARD OF COMMISSIONERS' APRIL 20, 2009 AGENDA

TO: BOARD OF COMMISSIONERS

FROM: GRAINGER BARRETT, COUNTY ATTORNEY *GB*

**SUBJECT: APPROVAL OF RESOLUTION OF APPROVAL OF TAX-EXEMPT
LOAN TO COTTON FIRE DEPARTMENT TO BUILD AN ADDITION
TO ITS FIRE STATION**

BACKGROUND: Under the Internal Revenue Code, the Board of Commissioners must adopt the attached resolution of approval of tax-exempt loan for Cotton V.F.D. in order for its \$350,000.00 financing to qualify as tax-exempt to the lender. This loan is for the purpose of constructing an addition to its fire station. This approval does not obligate the County in any way regarding repayment of the financing. Cotton VFD has requested that the Board of Commissioners approve the attached resolution.

RECOMMENDATION: Adopt resolution of approval of tax exempt financing by Cotton V.F.D. in the amount of \$350,000 for the purpose of constructing an addition to its fire station, and direct the clerk to deliver a certified copy of this resolution to the Fire Chief of Cotton V.F.D.

Atch.

Celebrating Our Past... Embracing Our Future

EASTOVER - FALCON - FAYETTEVILLE - GODWIN - HOPE MILLS - LINDEN - SPRING LAKE - STEDMAN - WADE

County Board Resolution

Resolution Approving the Financing by Cotton Volunteer Fire Department, Inc.

Of up to \$350,000 For an addition to Project

Cotton Fire Department

WHEREAS:

Cotton Volunteer Fire Department, Inc. has determined to finance an amount of up to \$350,000 for 15 years. The United States Internal Revenue Code requires that for such financing to be carried out on a tax-exempt basis, this Board must first approve the financing. The Fire Department has held a public hearing on the financing after published notice, as required by the Code. The Fire Department has reported the proceedings of such hearing to this Board.

BE IT THEREFORE RESOLVED by the Board of Commissioners of Cumberland County, North Carolina, as follows:

The County approves the Fire Department's entering into the financing, as required under the Code for the financing to be carried out on a tax-exempt basis. The Fire Department's conduct of the required public hearing is approved.

I hereby certify that the foregoing resolution was duly adopted at a meeting of the Cumberland County Board of Commissioners duly called and held on _____ 2008, and that a quorum was present and acting throughout such meeting. Such resolution remains in full effect as of today.

Dated this _____ day of _____, 2009

[SEAL]

By: _____
Clerk, Board of Commissioners
Cumberland County, North Carolina

COUNTY OF CUMBERLAND

NORTH CAROLINA

**PROCLAMATION
Air Quality Awareness Week**

WHEREAS, clean air is essential to public health, the environment and the economy in *Cumberland County*; and

WHEREAS, we need clean air to protect and improve the quality of our forests, streams and lakes for public recreation and wildlife; and

WHEREAS, we need clean air to sustain tourism, agriculture and other aspects of the economy; and

WHEREAS, the U.S. Environmental Protection Agency (EPA) and the National Weather Service urge Americans to "Be Aware of Our Air" during Air Quality Awareness Week, April 27 through May 1, 2008; and

WHEREAS, following a requirement of the Clean Air Act, the EPA recently strengthened the national air quality standard for ozone from 0.08 to 0.075 parts per million for improved human health and safety; and

WHEREAS, taking immediate action to improve air quality is of major concern to the Cumberland County Board of Commissioners and all the Municipal Governments; and

WHEREAS, the citizens and businesses of Cumberland County are invited to participate in the countywide effort to lower emissions of ozone precursors; and

WHEREAS, daily air quality forecasting will be available from the Department of Environment and Natural Resources Division of Air Quality from April 30 through September 30, 2008.

NOW, THEREFORE, BE IT RESOLVED, that the Cumberland County Board of Commissioners PROCLAIMS the week of April 26 through May 2, 2009, "AIR QUALITY AWARENESS WEEK" and calls upon citizens to observe the week with activities that promote clean air and take part in making our community a cleaner, healthier place to live, work, and play.

Adopted April 20, 2009.

Jeannette Council, Chairman

COUNTY OF CUMBERLAND

NORTH CAROLINA

PROCLAMATION

WHEREAS, the existing industries of Fayetteville and Cumberland County are an essential segment of the area's economy, providing employment for local residents, contributing revenues and greatly enhancing the area's quality of life; and

WHEREAS, the various industries existing in Fayetteville and Cumberland County have an influence either directly or indirectly upon the lives of every one of the county's citizens; and

WHEREAS, the potential for growth comes in part from within through the expansion of existing industries and the establishment of new, homegrown industries; and

WHEREAS, public awareness and understanding of the importance of industry to our local economy and quality of life are vital to the preservation of a favorable industrial climate; and

WHEREAS, a favorable industrial climate is a major factor in the decision made by officials of existing plants to expand their operations and in our area's ability to attract new industry.

NOW, THEREFORE, BE IT RESOLVED that the Board of Commissioners of Cumberland County proclaims the month of **May 2009 "INDUSTRY APPRECIATION MONTH"** in Cumberland County and urges its citizens to salute the industries located in our area and the employees of those industries for their important role in the growth and prosperity of Cumberland County.

Adopted this 20th day of April, 2009.

Jeannette M. Council
Board of Commissioners

COUNTY OF CUMBERLAND

NORTH CAROLINA

PROCLAMATION
WORKFORCE DEVELOPMENT PROFESSIONALS MONTH

WHEREAS, the economic development of every region in North Carolina and the ability of our businesses and industries to compete in the global economy is more than ever before dependent on the availability and quality of a skilled workforce; and

WHEREAS, the complexity and fast-paced change in our economy and labor markets puts new demands on individuals and employers at all level; and

WHEREAS, job seekers need the assistance of knowledgeable and dedicated professionals to facilitate the process by which our workforce identifies, prepares for, obtains and maintains employment and self-sufficiency; and

WHEREAS, employers depend on similar levels of professional services to help them recruit and retain a competitive workforce and to continually upgrade the skill sets of their incumbent employees;

NOW THEREFORE, BE IT RESOLVED, that the Board of Commissioners of Cumberland County joins with the State of North Carolina, the North Carolina Commission on Workforce Development, the North Carolina Employment and Training Association and the North Carolina Society for Human Resource Management in proclaiming the month of May as “**WORKFORCE DEVELOPMENT PROFESSIONALS MONTH**” to honor all those individuals in all the Workforce Development organizations and partnerships who play such a vital role in our economy.

Adopted this 20th day of April, 2009.

Jeannette Council, Chairman

COUNTY OF CUMBERLAND

NORTH CAROLINA

RESOLUTION

Acknowledging the long and proud history of the Association of the United States Army – Braxton Bragg Chapter - and its contributions to Fort Bragg, local soldiers and their families, we the Cumberland County Board of Commissioners hereby resolve that

WHEREAS, the Secretary of the Army has established 2009 as the Year of the NCO (non-commissioned officer) in recognition of their commitment to service and willingness to make great sacrifice on behalf of our nation and

WHEREAS, since 1775, the Army has set apart its NCOs from other enlisted soldiers by distinctive insignia and

WHEREAS, with more than 200 years of service, the US Army's Non-commissioned Officer Corps has distinguished itself as the world's most accomplished group of military professionals and

WHEREAS, NCOs have been celebrated for decorated service in military events spanning centuries, and

WHEREAS, the NCO Corps of the United States Army is one of America's great assets,

NOW, THEREFORE, BE IT RESOLVED, the Cumberland County Board of Commissioners expresses deep appreciation for all the soldiers who make up the US Army, and for the Association of the United States Army, who represents them so well. Our heartfelt best wishes are extended to all those who serve, especially the non-commissioned officer ranks.

Adopted this 20th day of April, 2009.

Jeannette Council, Chairman

**COUNTY OF CUMBERLAND
BUDGET REVISION REQUEST**

Budget Office Use	
Budget Revision No.	B09-335
Date Received	3/31/2009
Date Completed	

Fund No. 101 Agency No. 450 Organ. No. 4511

Organization Name: Soil Conservation Cost Share

ITEM NO. 1 Q (1)

REVENUE

Revenue Source Code	Description	Current Budget	Increase (Decrease)	Revised Budget
9901 (101-999-9999)	Fund Balance Appropriated		521	
Total			521	

EXPENDITURES

Object Code	Appr Unit	Description	Current Budget	Increase (Decrease)	Revised Budget
2393	372	Educational Supplies	0	521	521
Total			0	521	521

Justification:

Revision in the amount of \$521 to appropriate fund balance to roll forward the balance of unexpended Technical Assistance Grant funds from FY 2008.

Funding Source: State: _____ Federal: _____ Fund Balance: County: _____ New: _____ Other: _____
Other: _____ Fees: _____ Prior Year: _____

Submitted By: Kay B Bullard Date: 3/31/09
Department Head

Reviewed By: Bob Tucker Date: 3/31/09
Finance Department

Reviewed By: Amy D Connor Date: 4/15/09
Assistant County Mgr

Approved By:	
_____	Date: _____
County Manager	
_____	Date: _____
Board of County Commissioners	
_____	Date: _____

**COUNTY OF CUMBERLAND
BUDGET REVISION REQUEST**

Budget Office Use	
Budget Revision No.	B09-340
Date Received	4/6/2009
Date Completed	

Fund No. 620 Agency No. 444 Organ. No. 4442
 Organization Name: Civic Center

ITEM NO. 1Q(2)

REVENUE

Pg 1 of 2

Revenue Source Code	Description	Current Budget	Increase (Decrease)	Revised Budget
9139	Transfer from Fund 621	0	250,000	250,000
Total		0	250,000	250,000

EXPENDITURES

Object Code	Appr Unit	Description	Current Budget	Increase (Decrease)	Revised Budget
3430	857	Maintenance & Repairs - Building	215,862	250,000	465,862
Total			215,862	250,000	465,862

Justification:

Revision in the amount of \$250,000 to record transfer from the Hotel/Motel Occupancy Tax Fund to provide monies to replace inoperable LED panels on the Crown Coliseum scoreboard (\$200,000) and to replace a water heater at the Crown Coliseum (\$50,000).

Funding Source:

State: _____ Federal: _____ County: _____ New: _____ Other: _____
 Other: _____ Fees: _____ Prior Year: _____

Fund Balance:

Submitted By: Lisa Joch Date: 4/6/09
 Department Head

Reviewed By: Bob Jucher Date: 4/6/09
 Finance Department

Reviewed By: Amy Cannon Date: 4/15/09
 Assistant County Mgr

Approved By:	
_____	Date: _____
County Manager	
_____	Date: _____
Board of County Commissioners	
_____	Date: _____

**COUNTY OF CUMBERLAND
BUDGET REVISION REQUEST**

Budget Office Use	
Budget Revision No.	B09-344
Date Received	4/14/2009
Date Completed	

Fund No. 101 Agency No. 410 Organ. No. 4100

Organization Name: Governing Body

ITEM NO. 1 Q (3)

REVENUE

Revenue Source Code	Description	Current Budget	Increase (Decrease)	Revised Budget
9901	Fund Balance Appropriated		16,500	
		0	16,500	16,500

EXPENDITURES

Object Code	Appr Unit	Description	Current Budget	Increase (Decrease)	Revised Budget
1210	001	Salaries Regular	118,113	14,157	132,270
1810	001	Social Security Contribution	23,497	1,056	24,553
1820	001	Retirement Contribution	5,980	700	6,680
1824	001	Contribution 401K County	1,220	145	1,365
1830	001	Medical Insurance	47,700	442	48,142
		Total	196,510	16,500	213,010

Justification:

Revision in the amount of \$16,500 to payout Clerk to the Board in the amount of \$12,607 (retiring as of June 30, 2009) and train a replacement for the Deputy Clerk to the Board (who will be promoted to Clerk of the Board on July 1, 2009) in the amount of \$3,893.

Funding Source: State: _____ Federal: _____ Fund Balance: County: _____ New: 16,500 Other: _____
Other: _____ Fees: _____ Prior Year: _____

Submitted By: _____ Date: _____

Department Head
 Reviewed By: Kelly Aubrey Date: 4.14.09
 Finance
 Reviewed By: Amber Cannon Date: 4/15/09
 Deputy Assistant County Mgr

Approved By:	
County Manager	Date: _____
Board of County Commissioners	Date: _____

Donovan McLaurin,
Chair
Wade, Falcon & Godwin

Lori Epler,
Vice-Chair
Cumberland County

Garland C. Hostetter,
Town of Spring Lake
Harvey Cain, Jr.,
Town of Stedman
Patricia Hall,
Town of Hope Mills
Charles C. Morris,
Town of Linden



COUNTY of CUMBERLAND

Planning and Inspections Department

Thomas J. Lloyd,
Director

Cecil P. Combs,
Deputy Director

Walter Clark,
Roy Turner,
Sara E. Piland,
Cumberland County

Benny Pearce,
Town of Eastover

APRIL 10, 2009

ITEM NO. 2A

MEMO TO: Cumberland County Board of Commissioners

FROM: Cumberland County Joint Planning Board

SUBJECT: **Case P09-06:** Rezoning of 99.63+/- acres from PND Planned Neighborhood Development and R6 Residential to MXD Mixed Use Development/CUD Conditional Use District and the Permit or to a more restrictive zoning district located on the south side of SR 1611 (Andrews Road) and west of SR 1612 (Farmers Road), submitted by Attorney and General Manager Alfred E. Cleveland, owned by Andrews Road Company, LLC.

ACTION: Members present at the March 17, 2009 meeting voted unanimously to recommend approval of the Mixed Use Development/Conditional Use District and approval of the Conditional Use Permit with deletion of the Ordinance Related Conditions.

SITE INFORMATION: Frontage & Location: 3871.19'+/- on SR 1611 (Andrews Road); **Depth:** 1050.00'+/-; **Jurisdiction:** Cumberland County; **Adjacent Property:** Yes, two tracts south of subject property; **Current Use:** Vacant woodlands; **Initial Zoning:** PND & R6 – August 21, 1972 (Area 1); **Nonconformities:** None; **Zoning Violation(s):** None; **Surrounding Zoning:** North & East: PND (County & Fayetteville); South: PND, RR, R6/CU (to allow a manufactured home), R6/CU (to allow a double-wide manufactured home), R6A & R6 (County & Fayetteville) R10; West: PND & R6; **Surrounding Land Use:** 2- public schools, religious worship facility, 2- utility substations, cell tower, residential (including 2- multifamily and manufactured home); and woodlands; **North Fayetteville Area Detailed Land Use Plan:** Open space; **Special Flood Hazard Area (SFHA):** None; **Water/Sewer Availability:** PWC/PWC; **Watershed:** Yes; **Soil Limitations:** Yes, hydric: JT Johnston loam (open space area); **School Capacity/Enrolled:** Howard Hall Elementary: 550/587; Pine Forest Middle: 820/838; Pine Forest High: 1750/1603; **Subdivision/Site Plan:** See attached "Ordinance-Related Conditions"; **RLUAC:** No objection to this case; **Municipal Influence Area:** City of Fayetteville; **Average Daily Traffic Count (2006):** 17,500 on SR 1611 (Andrews Road); **Highway Plan:** Fayetteville Outer Loop is identified in the Highway Plan as a major thoroughfare. This proposal calls for a multi-lane facility (U-2519) with a right-of-way of 250 feet. Andrews Road is identified in the Highway Plan as a major thoroughfare. This proposal calls for widening to a multi-lane facility (4 lane divided). Andrews Road improvements are not included in the 2009-2015 MTIP. This road calls for a 90 foot right-of-way with a dedication of 10 feet and reservation of 5 feet. This is a Priority One Project under the LRTP. This property is located adjacent to the Fayetteville Outer Loop and Andrew Road; **Note: Density (minus 15% r/w) for PND (R7.5):** 491 lots/ 492 units.

MINUTES OF MARCH 17, 2009

Mr. Lloyd reviewed the site information and stated the staff recommends approval of the request for MXD Mixed Use Development/CUD Conditional Use District based on the following:

1. Although, the MXD/CUD is inconsistent with the North Fayetteville Land Use Plan, which calls for open space at this location, the recommendation is reasonable because the proposed development is in harmony with the surrounding existing development;
2. Approval of this district will protect the surrounding area from strip non-residential development; and
3. The request is reasonable because the district and uses proposed are in character with the current zoning and land uses of adjacent properties and would allow for development that is consistent within the existing development in the surrounding area.

The PND Planned Neighborhood Development/CUD Conditional Use District & Permit could also be found suitable at this location.

The Planning & Inspections Staff also recommends approval of the Conditional Use Permit, if the developer provides an inter-connecting right-of-way access between the residential portions of this development, based on the following:

1. The requested use will not materially endanger the public health and safety if located according to the site plan submitted and recommended;
2. The use will meet all required conditions and specifications if constructed according to the site plan, application and conditions – a copy of the *Ordinance-Related Conditions* pertaining to this site is attached;
3. The use will maintain or enhance the value of adjoining or abutting properties in that the subject property is currently undeveloped thus a quality well-planned development, if developed as submitted, would enhance the value of the general area; and
4. The location and character of the use, if developed according to the site plan as submitted, will be in harmony with the area in which it is to be located.

Mr. Lloyd stated that in an established neighborhood, many times established residences do not want access to apartment complexes located adjacent to them staff also felt, not only would this interconnection be needed for possible emergencies, but also this being an undeveloped property those that do buy into the single family will at this point know that there will be multi-family based on the plan. So it won't be a surprise, it is included in the plan.

There were people signed up to speak in favor and in opposition.

Vice-Chair Epler asked if the new Fire Code required a new multi-family development over 100 units have two means of egress and ingress.

Mr. Lloyd responded that Cumberland County had not adopted that, but we are not sure. But it has been adopted in some places.

Chair McLaurin had all speakers come forward to be sworn in.

Al Cleveland spoke in favor. Mr. Cleveland stated that he was the Managing Partner of Andrews Road Company which is a Limited Partnership formed under the laws of North Carolina in 1970. Mr. Cleveland went on to name the owners of the company. Mr. Cleveland stated that the property was proposed to be sold to Mr. John Koenig and Mr. Walsh and they have been intimately involved with the proposed development of this property. Mr. Cleveland thought it would be better if Mr. Koenig spoke before the Board.

Mr. Barrett asked Mr. Cleveland to elaborate on whether his company was an LLC or Limited Partnership.

Mr. Cleveland stated that he misspoke and his company is an LLC.

Phyllis Owens spoke in favor. Ms. Owens stated that she was present as a member of the Economic Development Growth for the Fayetteville Chamber of Commerce. Ms. Owens stated that her organization has worked for some period of time with the business development applicant. They have been a long term company in our community and they provide numerous jobs in the local community. They are considered to be one of our best defense contractors and of course that leads me to say BRAC. As we approach BRAC one of the needs as a developer is office space, in some cases flex space. As we approach 2011 when Forces Command will open we are seeing, on a daily basis, additional companies coming to our community seeking space, such as what is proposed. Ms. Owens said that she understands that change is a difficult thing, and when it's her backyard she may be on the other side of the fence. But for now Fayetteville and Cumberland County is going to change. It is going to change drastically; it is going to change in large numbers. So having developers like this who study a plan and study a site and come with a reasonable offer is going to be something we will see a lot more of. Ms. Owens hopes that the Board will take the first step and allow this project to move forward so we can begin to put some of the clients she has, in quality office space and bring the community into the 21st century.

Chair McLaurin allowed questions from other speakers.

Mr. Alex Rogers asked Ms. Owens what she meant by flex space.

Ms. Owens stated that flex space could actually be office space but it has a large workbench area which is referred to as an office with a warehouse attached to it.

Mr. Rogers stated that that would lead him to believe that is commercial space.

Ms. Owens stated yes, she promoted all the Winn Dixie's in the area as flex space.

Mr. Lloyd said that in the City it can be, but in the County it will not be used as commercial.

Ms. Owens stated that her need was for flex space but this project is not talking about that.

Mr. Rogers asked about the growth in relation to BRAC and asked Ms. Owens to quantify that in numbers.

Ms. Owens stated that there would be 40,000 new residents in this region, it is expected that Cumberland County will get a majority of the 40,000 residents and 19,000 new jobs will be created. The new jobs will be with this project on an 11 County regional basis with BRAC RTF, about 1,200 of those jobs will be at Forces Command Headquarters on Fort Bragg, and a number of the jobs will be in the military business park, some in office buildings on Executive Drive and a number of other office buildings. BRAC 2005 is going to bring new jobs to the community; a development such as this is the beginning of what we are going to see much more of as we move forward in providing the space required by the defense contracting company.

Mr. Rogers asked Ms. Owens which contracting companies she was referring to.

Ms. Owens stated that as an economic developer she couldn't divulge who the clients are, but by taking a look around the community many of them are already here and stated that similar companies would be coming.

Mr. Rogers asked if the proposed area was in the City of Fayetteville.

Chair McLaurin stated that the area is in the County.

Mr. Morris asked Ms. Owens where the data came from for the study that she had referred to.

Ms. Owens stated that the data came from BRACRTF.com, where it talks about transition transformation, TDA did a complete study of an 11 County region, 73 municipalities and each of those is broken down into an individual count. The total in the opening summary says 40,000 new people. The estimate runs from 25,000 – 40,000, but the people running the task force say the number is closer to 40,000.

Richard Braid asked if the property would be annexed into the City.

John Koenig spoke in favor. Mr. Koenig stated that he was asked by Mr. Walsh to join in assisting with developing this piece of property. Mr. Koenig stated that Mr. Walsh is currently a tenant of his and has been there for about ten years. Mr. Koenig said that Mr. Walsh has military contracts from Ft. Knox, Ft. Dix, N.J., Ft. Hood, TX, and Ft. Bragg, N.C. He employs 1100 people and does all the refurbishing for military vehicles. He is a bona-fide defense contractor and he needs office space. Mr. Koenig presented the design of the proposed development and explained how certain areas were designated. Mr. Koenig stated that there was more than ample green space and no problems with a sidewalk. The only problem was the interconnectivity between the residential and multi-family residences. However, Mr. Koenig believes that something can go in, in case of an emergency. Mr. Koenig stated that he didn't know if this area would be annexed into the City. Mr. Koenig stated that public sewer and water is needed, but there is a provision that says that if you sign up you might get annexed.

Mr. Barrett asked Mr. Koenig if he stated that he did not agree with the staff request for access.

Mr. Koenig stated yes and went on to explain connectivity.

Mr. Barrett stated that he understood connectivity, but under the conditions of a Conditional Use Permit the applicant must accept the conditions, so Mr. Barrett just wanted to be clear for the record whether or not Mr. Koenig accepts the conditions.

Mr. Koenig said that when he talked to staff he understood that he could put a gate for passage that is not used.

Mr. Lloyd said that that has been done in the past.

Mr. Barrett asked if that was acceptable to staff.

Mr. Lloyd said that would be acceptable.

Mr. Tony Brill asked Mr. Koenig to clarify what he said about sewer.

Mr. Koenig said that sewer is on the property.

Mr. Brill said there is no sewer on the property.

Mr. Koenig responded that there is not now but there will be.

Mr. Brill asked about all the other areas that were waiting for sewer.

Mr. Koenig said that that is not his responsibility.

Mr. Richard Braid asked Mr. Koenig what the target price range would be for the homes.

Mr. Koenig said that the homes would be at or below two hundred thousand dollars. Mr. Koenig said that when you bring sewer and water and develop infrastructure it's impossible to build a house for one hundred and fifty thousand dollars.

Mr. Braid asked about the apartment sizes.

Mr. Koenig said that would be based on market demands.

Mr. Alex Rogers asked about the size of the single family homes for two hundred thousand dollars.

Mr. Koenig said he couldn't answer that.

Mr. Rogers asked if the multi-family homes would be a subsidiary of Mr. Koenig's organization and only be rented out or will they be available as condominiums.

Mr. Koenig said probably as condominiums.

Mr. Walt Dietrich asked Mr. Koenig if the sidewalk would extend all the way down to the apartments.

Chair McLaurin asked Mr. Lloyd if they would have to extend all the way down to the apartments.

Mr. Lloyd said that they would.

Mr. Koenig said that the staff recommendation was that they be the length of the property.

Mr. Lloyd wanted to clarify that this development was approved for multi-family apartments, not condominiums. Condominiums have a different set of requirements, so we need to clear that up.

Mr. Terry Samperton asked if the neighborhood would be governed by a homeowners association.

Mr. Koenig said that if there is an entrance and anything else that needs to be maintained it's good to have an association. There will be a homeowners association for both the single family and multi-family residences.

Mr. Dwight Utley asked Mr. Koenig if he was aware that there was a large inventory of homes available just down the road that ranged in price from one hundred and fifty thousand dollars to two hundred thousand dollars.

Mr. Koenig stated that he was aware of that.

Mr. Jimmy Kizer spoke in favor. Mr. Kizer stated that the plan being presented is something that he has worked on with staff over a period of time; initially they were looking at just doing a rezoning for the office building. Staff looked at the overall site and thought this would be a good candidate to do as a Conditional Use Development, to go ahead and put all of the pieces of the puzzle on the table and approve it that way. So that everyone in the area knows what they are getting up front and there are no questions, not all these rumors going around about what's going to happen on site. Working with staff and going over the conditions we've come up with this plan and the percentage of the areas on it to try and hit the targets that are desired for doing a Conditional Use Development. Mr. Kizer feels that they have exceeded the minimums in several cases. Mr. Kizer addressed Vice-Chair Epler's comments about entrance access and stated that what they have found in working with cities and other municipalities is it varies depending on who you work with, if there is a divided entrance, even on a multi-family complex and there is enough width on each side of that divided entrance, both sides will be looked at as having access points.

It can be worked around, and even the City of Fayetteville is okay with doing that. So, if there is 25 feet on each side of that entrance aisle coming into a project, by definition there are two access points. It is looked at as highly unlikely that both those entrances will be blocked at any one particular time. The biggest problem that we have with interconnectivity between the two of them is if it's done as a right-of-way, because the traffic flow cannot be controlled from one end to the other. If something is put back there, it can be done in a twenty foot easement or some kind of access alleyway that can be gated or be graveled, but only be used for emergency access. Therefore, there is no undue burden on either of the developments with people going back and forth to the amenities associated with the apartment complex. Mr. Kizer stated as far as water and sewer goes, in the back near the wetlands area, in the apartment part of the complex, gravity sewer already exists. The gravity sewer that goes up to Andrews Road serves Inverness Subdivision, there is a lift station there. The gravity sewer around the lowlands was put in as part of the annexation process. Water is already there along Andrews Road and it is designed to pick up additional flows.

Vice-Chair Epler asked Mr. Kizer if the streets would be public or private.

Mr. Kizer stated that they would be private in the apartment complex only.

Mr. Richard Braid asked Mr. Kizer if the sewer system would be appropriate for the area.

Mr. Kizer stated that it would be appropriate; it would all be gravity sewer.

Mr. Braid asked about the traffic situation as far as traffic lights or stop lights.

Mr. Kizer stated at this point there are comments from the Department of Transportation (DOT). We don't meet their requirement credentials for doing a traffic impact analysis with what we are proposing to do. More than likely at this point he would anticipate at a minimum road widening, a turning lane, and a stop light. Right now they are trying to get away from stop lights, they look at your assets and when there aren't multiple turns or an intersection, they want to offset them.

Mr. Terry Samperton spoke in opposition. Mr. Samperton stated that right now that road cannot handle the increased traffic. There is way too much traffic for a small road. The DOT has marked the road, but Mr. Samperton stated that he isn't aware of what the plan is. Mr. Samperton stated that the road is used as a shortcut to Ft. Bragg and there is heavy traffic there for Pine Forest High School, the road is gridlocked anytime school is open. This plan is way too much for what is there now. Traffic lights will need to be there, when you come out of the entrance at Inverness, there is a hill, the speed limit is forty-five miles an hour and some people are coming over that hill at a high rate of speed. With another entrance directly across from us and one hundred and twenty-six more homes that isn't going to work. Mr. Samperton stated that he is against the apartment complex; there are other apartments in Harbor Oaks that aren't even filled up yet, so we don't need more apartments. There is an office park being built for the people who want to be attached to Ft. Bragg, we don't need this office complex. Mr. Samperton said he didn't have a problem with the planned neighborhood, but something has to be done about the entrances. Mr. Samperton stated that he feels it's way too much for such a small piece of property.

Mr. Richard Braid spoke in opposition. Mr. Braid stated that sixteen acres is quite a bit of space for that area. From the office complex that would be about half the size of the Walmart complex on North Ramsey Street. From there, either side is a mile to any commercial activity going on; it's all single family residences on both sides of the street except for the two schools and the church. Mr. Braid referenced Mr. Samperton's comments about the traffic on that road and agreed that the traffic was terrible. Mr. Braid feels that that amount of traffic will affect the safety of the children walking to and from school even if they are walking on the sidewalks. Mr. Braid said that he was concerned about the value of homes in the area.

It would degrade the value of the property that have bought into Inverness. A big issue for Mr. Braid is the water run-off, it is all downhill and there have been problems with the Woodbridge area with water run-off from the Inverness area and people are getting flooded out in their garages from excess run-off because all of the trees are gone and the water wasn't routed properly for drainage. Mr. Braid stated that the Military Business Park will have 215 acres, which is a lot of space dedicated for the contractors, and there are quite a few empty commercial buildings throughout the County and City that could be renovated for commercial space, rather than having to build brand new office space in the middle of residential areas.

Mr. Clark asked if there was a traffic count on the road.

Chair McLaurin said that in 2006 it was 17,500 according to the site profile.

Mr. Braid stated that count didn't include a lot of the traffic coming off of the end of I-295 exit at Ramsey Street. They get off and can cut across, and a lot of trucks come through there. The traffic has increased dramatically since the road had been opened.

Mr. Clark stated that he had addressed this to Mr. Lloyd, but had the water runoff been taken into account.

Mr. Lloyd stated that it was listed as a condition under Permit-Related, but the County falls under Phase II Stormwater regulations which the State reviews and those plans have to be submitted to the state. So the Stormwater has been addressed.

Vice-Chair Epler stated to Mr. Braid when all the rest of the neighborhoods in that area were developed Cumberland County was not under Phase II Stormwater regulations, the County is now. On their site plan they have several areas set aside where they will actually collect their own stormwater on site, it will not leave their site, and it will infiltrate back down into the ground and never leave their property. This development, in that area will have to take precautions that no other development in that area has had to.

Mr. Braid stated that Inverness has collection basins and they don't work.

Vice-Chair Epler stated that Inverness was not regulated by the State, like they are now.

Mr. Lloyd stated that Ms. Speicher advised him that those basins were cited for violations.

Mr. Koenig asked Mr. Braid if he had taken into consideration when I-295 is open how that will alleviate the traffic.

Mr. Braid stated that it wouldn't be completed for five or six years.

Mr. Lloyd stated that if this was developed at PND standards which means the whole lot could be developed at R7.5 you could have 491 units as opposed to what is being proposed now which is 320 units. If this was brought in as a straight residential development there would be 170 units more. Mr. Lloyd went on to say that a Planner did look up the traffic generation of offices and according to what they found, school would already be in and that traffic would already be off the road before most of the people that use the offices would be on the road and school would be out before most of the people who use the offices would be leaving.

Mr. Alex Rogers spoke in opposition and stated that to build a two hundred thousand dollar home in an area where most of the homes are well above that for their assessment value right now, and when we bring I-295 in that will drive the prices of these homes down even more because they are right on the border of an interstate highway. Mr. Rogers stated that he couldn't imagine that the homes would maintain their value. Mr. Rogers also stated that there are people on their way to work at the same time that school children and school buses are on the roads. Fairfield Farms

and Greystone Farms at the end of Andrews Road also feed all of their traffic currently down Andrews Road to contribute to the traffic problem. Mr. Rogers stated that he sees that every day because he has to leave early to get to Ft. Bragg. So, Mr. Rogers stated, that as a resident he stands in opposition of this development.

Mr. Tony Brill spoke in opposition and stated that traffic is horrendous, it is almost impossible to turn left or right going in either direction. Mr. Brill also brought up the fact that they had been waiting for sewer for at least fifteen years and nothing has been done. Mr. Brill asked how these new projects can be so far ahead of those who live in the area.

Chair McLaurin stated that the developer pays all the cost.

Mr. Brill stated that he wasn't opposed to the project, but feels that the timing is wrong.

Mr. Dwight Utley spoke in opposition. Mr. Utley stated rezoning the property was unnecessary. When it was first discussed as O&I, he went and drove the area and within one mile of the property, existed five acres along the Ramsey Street corridor that's available for ground up development for either commercial or O&I. Within 2.2 miles of this property there are 7,000 square feet of vacant building space that can be utilized for commercial or O&I purposes, within 3 miles of the property there are seven different office buildings all with available office space. On page 19 of the Ramsey Street Corridor Plan that the City commissioned, it says that there is 253 thousand square feet of commercial space along the Ramsey Street corridor. This is less than five miles from the area that is being discussed tonight. Mr. Utley stated that he stands in opposition to any type of office space for commercial development in the area. Mr. Utley stated that there are 11 apartment complexes within four miles of this property, all with vacancies.

Chair McLaurin asked Mr. Koenig if he wanted to speak in rebuttal. Mr. Koenig declined.

Mr. Morris asked Mr. Koenig what his timetable was.

Mr. Koenig stated that this project would be completed in phases. The office complex will be the first phase.

Mr. Lloyd stated that the ordinance requires at least half of the proposed residential development or some guarantee that the residential be built will have to have a certificate of occupancy issued for half of the residential development prior to the completion of the approved office. By ordinance, if not there has to be a bond or irrevocable letter of credit with the estimated cost of construction being approved by the County Engineer.

Mr. Morris stated that basically half of the residential has to be completed prior to the O&I.

Mr. Walt Dietrich asked once this is approved if the plans could change.

Mr. Barrett stated that there could be minor changes without a process similar to this that requires a public hearing and the opportunity for public comments.

Chair McLaurin closed the Public Hearing.

Mr. Morris stated that he knew PND was dormant, but, if we do nothing and this was developed as PND there would be five acres commercial and density would be at 7.5 which would be 491 units.

Mr. Lloyd stated that the provision is not in PND to build a certain amount of residential, commercial can be built and residential left vacant, it has been done in the past, not by this Board; but what staff was afraid of was once commercial got in there, although it would be in the PND plan, the owner of the property could come back and rezone as a set commercial piece of

property, rezone the other residential and come back in the future and strip it down saying that commercial is already there. That has happened on Morganton Road. So staff felt like, in light of all of that, it would be better to have the less intrusive office there along with residential instead of running the risk of future strip of non residential down Andrews Road.

Vice-Chair Epler stated that she was sympathetic to the residents in the area and understands their plight. They are watching the City of Fayetteville get closer everyday it seems, they're seeing houses being built in places where their kids probably used to play and not have to worry about being run over by cars. But, this is also an area where those same kids have been known to get on four-wheelers and take off on those roads near Ft. Bragg and hit trees and hurt themselves. We are living in a time where people are not as responsible as they used to be about their kids, their business, their cars, about a lot of things. In this case, these developers have come before us and they have a plan for almost one hundred acres of land. By using the tools that the County has supplied them in a mixed use development, they are trying to implement uses for this property, which is their right, which will be better for the residents as neighbors. Many of the things that are utilized in a mixed use development are conducive to the neighborhood, and yes they bring more people which thereby brings more cars, and that is probably the biggest downfall. But we can't do the business of the Department of Transportation, once those cars are there it is the Department of Transportation's responsibility to keep them safe, and hopefully as Fayetteville and Cumberland County grows our Department of Transportation will take that responsibility a little heavier than they do now. That takes time, but this area is probably a little more suitable for what we see before us. When I-295 does go through, and it will eventually go through, it is going to relieve a lot of the traffic that is there right now. It will make it better for the schools, make it safer for those kids coming and going. BRAC, whether we like it or not is going to bring more people but it's also going to bring more jobs and Cumberland County really needs that right now. Vice-Chair Epler stated that she doesn't want to be the person to say that we don't want any more jobs or businesses in Fayetteville. This development will make it a little easier than almost five-hundred single family homes and five acres of anything commercial, with no buffers except what was minimal by the landscape ordinance. These developers, by using the mixed use development will have to buffer themselves to an extent, they will have to comply with Phase II Stormwater regulations, which works when done right and is very expensive, and the State will regulate that, not the County, they will also have to comply with watershed regulations, watershed puts them in a whole new category. Vice-Chair Epler said she commends the developers for coming in with a plan where they have made good use of their property without going in and stripping it and doing the maximum that they could in the neighborhood. Vice-Chair Epler went on to say that she felt the developers have done a good job and she would support the rezoning.

Vice-Chair Epler made a motion, seconded by Mr. Morris, that the Joint Planning Board finds that this Conditional Use District application is reasonable, neither arbitrary nor unduly discriminatory, and in the public interest, and that the Conditional Use District with the uses as shown on the plan are approved with the alterations as agreed to by staff. Unanimous approval

A motion was made by Vice-Chair Epler and seconded by Mr. Morris to approve the Conditional Use Permit as recommended by the staff for Mixed Use Development and other permitted uses with deletion of item #29 after finding that when completed, the proposal: 1) will not materially endanger the public health and safety; 2) will not substantially injure the value of adjoining or abutting property; 3) will be in harmony with the area in which it is to be located; and 4) will be in conformity with the land use plan, thoroughfare plan or other plan officially adopted by the Board of Commissioners, and she noted that the applicant had agreed to all recommended conditions. Unanimous approval

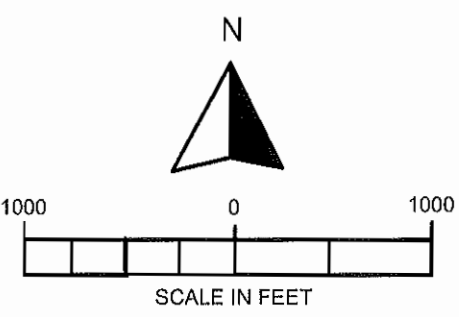
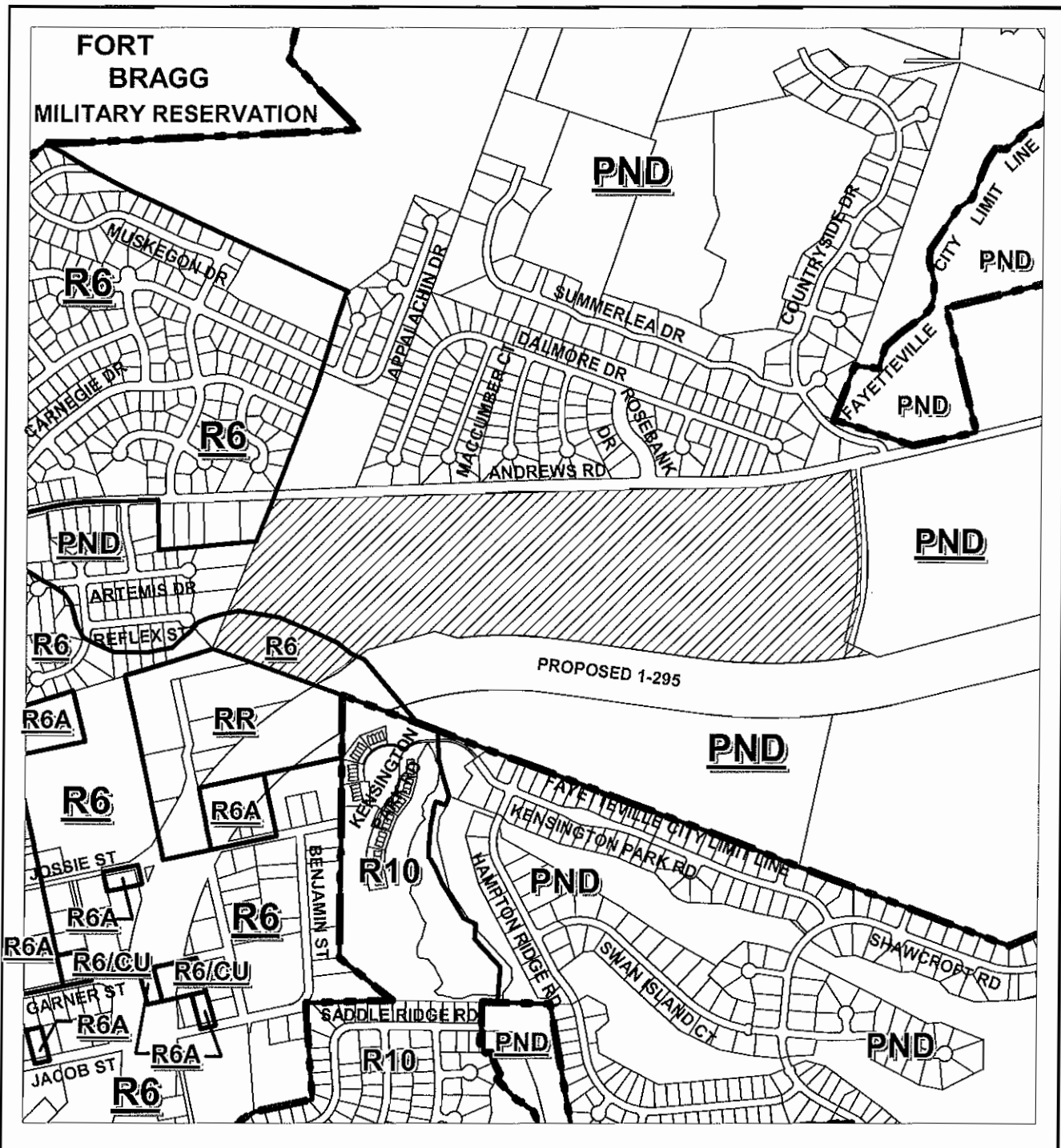

PORT OF PIN: 0531-00-6612
 PORT OF PIN: 0530-39-4583

REQUESTED REZONING PND & R6 TO MXD/CUD

ACREAGE: 99.63 AC.+/-	HEARING NO: P09-06	
ORDINANCE: COUNTY	HEARING DATE	ACTION
STAFF RECOMMENDATION		
PLANNING BOARD		
GOVERNING BOARD		

OF SINGLE FAMILY: 128 LOTS
 # OF APARTMENTS: 192 UNITS, (8 EACH, 3-STORY, 24 UNIT BLDGS)
 # OF STORIES FOR OFFICE CONDOS: 3 STORIES PER BLDG (4 BLDGS, 124,950 SQ. FT. TOTAL)

*Calculation based on total land area 99.63± acres
 18% Open Space - 17.68± acres

*Calculations based on net land area of 81.95 acres
 56% Single Family - 45.86± Acres
 24% Apartments - 20.06± Acres
 20% Professional (Office Condos) - 16 ± Acres

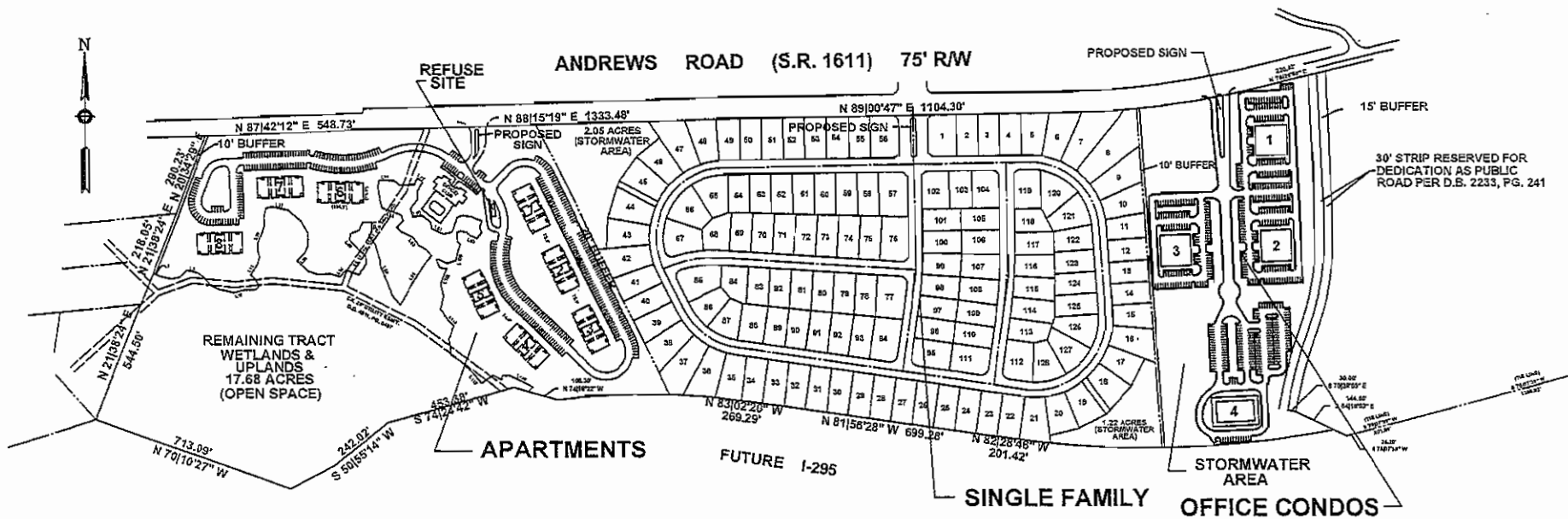

MIXED USE DEVELOPMENT - CONDITIONAL USE DISTRICT & PERMIT
CASE: P09-06 ACREAGE: 99.63±
SCALE: NTS

*SCALED DETAILED SITE PLAN IN FILE AVAILABLE FOR REVIEW UPON REQUEST

2/26/2009
 3/10/2009

Mixed Use Development - Conditional Use District & Permit

Ordinance-Related Conditions

Watershed-Related:

1. An application for watershed approval must be submitted to the Watershed Review Officer (WRO) and plans must be approved by the WRO prior to final plat approval and/or prior to application for any building/zoning permits. (Note: This approval may require additional conditions restricting the development of this property.) A copy of the WRO's approval of this plat/plan must be submitted to Code Enforcement at the time of application for any permits.
2. Prior to application for the building final inspection, a Watershed Occupancy Permit must be issued for each lot/tract within this development.

Permit-Related:

3. The owner/developer(s) of these lots must obtain detailed instructions on provisions of the County Zoning Ordinance and permits required to place any structure within this development from the County Code Enforcement Section, Room 101 in the Historic Courthouse at 130 Gillespie Street. For additional information, the developer should contact a Code Enforcement Officer.
4. Connection to public water and sewer is required, the Public Works Commission (PWC) must approve water and sewer plans prior to application for any permits. A copy of the PWC approval must be provided to Code Enforcement at the time of application for building/zoning permits. (Section 2306 A.1, Public Water and Sewer Systems County Subdivision Ordinance)
5. New development where the developer will disturb or intends to disturb more than one acre of land is subject to the Post-Construction Stormwater Management Permitting Program (Phase II Stormwater Management Requirements) administered by the Division of Water Quality, North Carolina Department of Environment and Natural Resources. If one acre or more of land is to be disturbed, prior to the issuance of any building/zoning permits for this site, a copy of the State's *Post-Construction Permit* must be provided to County Code Enforcement.
6. For any new development where the developer disturbs or intends to disturb more than one acre of land, the developer must provide the Code Enforcement Section with an approved NC Department of Environment and Natural Resources (NCDENR) *sedimentation and erosion control plan (S&E) prior to any application for permits. (Note: If any retention/detention basins are required for state approval of this plan, then three copies of a revised plan must be submitted and approved by Planning & Inspections prior to application for any building/zoning permits.) A copy of the NCDENR approval must be provided to Code Enforcement at the time of application for any building/zoning permits.*
7. The developer must provide a site-specific address and tax parcel number at the time of building/zoning permit application.
8. Landscaping must be provided in accordance with Section 1102 N, Landscaping, County Zoning Ordinance and be shown on the site plan for the office area portion of this development. Three copies of a revised site plan for the office area depicting the landscaping must be submitted to Land Use Codes prior to application for any permits. The following are the minimum standards for the required landscaping for the office area portion of this development:
 - a. Fourteen large shade trees or 26 small ornamental trees within the front yard setback area along SR 1611 (Andrews Road);
 - b. Eight ornamental trees and 85 shrubs are required in the building yard area;
 - c. Twenty two large shade trees or 44 small ornamental trees are required within the parking area.

In addition:

- a. Required plant materials shall be maintained by the property owner, including replacing dead or unhealthy trees and shrubs; and
 - b. All yard and planting areas shall be maintained in a neat, orderly, and presentable manner and kept free of weeds and debris.
9. The building final inspection cannot be accomplished until a Code Enforcement Officer inspects the site and certifies that the site is developed in accordance with the approved plans.

Site-Related:

10. All uses, dimensions, setbacks and other related provisions of the County Subdivision and Zoning Ordinances for the MXD/CUD zoning district must be complied with, as applicable. (Note: The setbacks for the periphery of this development must comply with those of the adjoining zoning districts and only those office uses allowed as specified in Section 603 of the County Zoning Ordinance shall be permitted within the "office" area as shown on the site plan.)
11. All corner lots and lots fronting more than one street must provide front yard setbacks from each street, except where access to the street has been denied.
12. This conditional approval is not approval of the permit for any freestanding signs. Attached signage for this development must be in accordance with the applicable sign regulations as set forth in Article XIII of the County Zoning Ordinance and that the proper permit(s) must be obtained prior to the installation of any permanent signs on the property. (Note: This conditional approval is

not approval of the size, shape, or location of any signs.) The NC Department of Transportation (NCDOT) must also approve the sign location for those signs located within the median strips.

13. All applicable provisions of Section 2401, "Group Developments", County Subdivision Ordinance, must be complied with.
14. Concrete curbs and gutters complying with the City of Fayetteville standards and specifications are required. Rolled concrete curb, if allowed, must not be less than 24 inches in width. (Fayetteville MIA)
15. For any new development, an adequate drainage system must be installed by the developer in accordance with the NC Department of Environment and Natural Resources' (NCDENR) *Manual on Best Management Practices* and all drainage ways must be kept clean and free of debris. (Section 2306 D, County Subdivision Ordinance)
16. For new development, all utilities, except for 25kv or greater electrical lines, must be located underground. (Section 2306 C, County Subdivision Ordinance)
17. The owner/developer shall secure and maintain the detention/retention basin, keeping it clear of debris and taking measures for the prevention of insect and rodent infestation.
18. This review does not constitute a "subdivision" approval by NC Department of Transportation (NCDOT). A separate submittal to NCDOT will be required prior to consideration for addition to the system of any street within this development.
19. The developer must obtain a driveway permit from the NC Department of Transportation (NCDOT). A copy of the approved driveway permit must be provided to Code Enforcement at the time of application for building/zoning permits.
20. The NC Department of Transportation (NCDOT) must approve the street plans and the street(s) are required to be constructed to the City of Fayetteville street standards or the NCDOT standards for secondary roads, if NCDOT is more restrictive.
21. The right-of-way width of the three median strips is required to be a minimum of 70 feet with the median strips not being less than 10 feet wide.
22. Turn lanes may be required by the NC Department of Transportation (NCDOT).
23. All lighting is required to be directed internally within this development and comply with the provisions of Section 1102 M, Outdoor Lighting, County Zoning Ordinance.
24. A solid buffer must be provided and maintained along the boundary of the multi-family and office areas within this development, except where these areas abut a right-of-way in accordance with the provisions of Section 1102 G, Buffer Requirements, County Zoning Ordinance. (Note: Chain link fencing cannot be used to satisfy the buffer requirement.)
25. All dumpster, garbage, and utility areas shall be located on concrete pads and screened on a minimum of three sides.
26. All required off-street parking spaces measuring a minimum of 9' x 20', are required to be surfaced, with a permanent material such as asphalt or concrete, and striped prior to application for the building final inspection. A minimum of 288 off-street parking spaces for the multi-family area and 416 spaces for the office area are required for this development.
27. All notes and calculations as shown on the site plan are to be considered as a part of this conditional approval.

Plat-Related:

28. The areas labeled as stormwater areas, wetlands & uplands (open space) and all other commonly owned property must be labeled as "common area" on the final plat.
29. A concrete walkway, minimum of 10 feet in width, must be constructed connecting this development with the County Board of Education property. The developer must contact the Board of Education regarding the preferred walkway location. *PENDING CLARIFICATION FROM THE SCHOOL BOARD.*
30. Concrete or other approved surface material, sidewalks are required to be constructed along one side of all streets, to include along SR 1611 (Andrews Road). (5 or more du/ac). (Section 2305, Sidewalks, County Subdivision Ordinance)
31. Fire hydrants must be installed along the proposed streets and drives; hydrants must be located no further than 1,000 feet apart and at a maximum of 500 feet from any lot/unit. (Section 2306 B, Fire hydrants, County Subdivision Ordinance)
32. The developer is required to submit to Land Use Codes, three (3) copies of the legal documents specifically designating responsibility for maintenance and upkeep of all stormwater, recreational/open space and commons areas through an owners' association for this development. These documents must be approved by the County Attorney prior to the sale of or submission for final plat approval of any lot or unit within this development.
33. The developer must contact the Street Naming Section of the Planning & Inspection for approval of street names for the proposed streets and drives within this development. The approved street name must be reflected on the final plat for each section. (Note: The developer must provide the Land Use Code Section of the Planning & Inspection Department a copy of a site plan showing the approved street names on the plan.)
34. The street name signs, in compliance with the County Street Sign Specifications, must be installed prior to final plat approval. The developer should contact E911 Street Naming/Signs for inquiries regarding the County's policy for street sign installation or, if the sign is commissioned from a private source, to schedule an inspection of the street sign(s). Land Use Codes must receive

notice of agreement with the Street Naming & Addressing Section for sign installation or of satisfactory inspection prior to the approval of the final plat.

35. Dedication of 10 feet of right-of-way and reservation of 5 feet of right-of way along SR 1611 (Andrews Road) is required and the metes and bounds for both dedication and reservation is required to be shown on the final plat and/or reflected on any future site plans. The location of all improvements, required or otherwise, and all building setback lines are to be measured from the ultimate right-of-way line. (Section 2302 F, Planned Public Right-of-Way, County Subdivision Ordinance)
36. The builder/developer must provide the buildable envelopes on the final plat: providing a five-foot maintenance easement along each side of all common internal lines with all other applicable setbacks being provided for; or at the time of permit application, the individual plot plans must be approved by Land Use Codes prior to issuance of any permits.
37. Any/All easements must be reflected on the final plat and labeled as to type of easement, reference number for document creating the easement, and the name of the agency, individual, etc. who holds the easement.
38. Twenty foot wide utility easements must be provided and reflected on the final plat along all rear lot lines (10 feet on each side) for the residential portion of this development and also must be provided for the non-residential portion if deemed necessary by the City Engineer.
39. All lots within this development must be served by an internal street system and a "no access" easement must be reflected on the final plat where Lots 1-8 and 47 – 56 abut SR 1611 (Andrews Road).
40. A 10' x 70' sight distance easement is required at the intersection of SR 1611 (Andrew Road) with the proposed streets and drives and must be reflected on the final plat.
41. A 25' right-of-way radius is required at all intersections and must be reflected on the final plat. (Section 2304.10.c, Street Design, County Subdivision Ordinance)
42. The NC Department of Transportation (NCDOT) stamp must be affixed to the final plat prior to submission for final plat approval by Land Use Codes.
43. The notarized signature(s) of all current tax record owner(s) and notary certifications appear on the final plat when submitted for final approval. (Section 2503 D, Certificate of Ownership and Dedication, County Subdivision Ordinance)
44. The developer is reminded that the improvements must be in place or that final plat approval will only be granted in accordance with Section 2502 B, C, or D, Final Plat – Guarantees of Improvements, Subdivision Ordinance. (Note: Once the improvements are in place, the developer is responsible for contacting Jeff Barnhill to schedule an inspection of the improvements.)
45. The final plat must be submitted to Land Use Codes for review and approval for recording with the County Register of Deeds, and the plat must be recorded prior to any permit application for any structure and/or prior to the sale of any lot or unit within this development.

Plat-Required Statement:

46. All structures shall be shown on the final plat or the final plat shall reflect the following statement (Section 2504 D, County Subdivision Ordinance):

"Nonconforming structures have not been created by this subdivision."

Other Relevant Conditions:

47. The applicant is advised to consult an expert on wetlands before proceeding with any development.
48. The owner/developer is responsible for ensuring easements which may exist on the subject property are accounted for, not encumbered and that no part of this development is violating the rights of the easement holder.
49. This conditional approval is contingent upon all rights-of-way being "public"; if the developer intends to construct "private" streets to serve this development, five copies of a revised site plan shall be required to be submitted to Land Use Codes for review and approval prior to submission for final plat approval of any portion of this development.

If you need clarification of any conditions, please contact Ed Byrne at 910-678-7609 or Patti Speicher at 910-678-7605; otherwise, contact the appropriate agency at the contact numbers below.

Contact Information (Area Code is 910 unless otherwise stated):

Watershed Officer/Improvements:	Jeff Barnhill	678-7765
Subdivision/Site Plan/Plat	Ed Byrne	678-7609
Code Enforcement (Permits):	Ken Sykes	321-6654
PWC:	Heidi Maly	223-4773
Fayetteville Planning:	Marsha Bryant	433-1416
Fayetteville Engineer:	Rusty Thompson	433-1660
Corp of Engineers (wetlands):	Ronnie Smith	(910) 251-4829
NCDENR (E&S):	Sally McKinney	433-3300
E911 Site-Specific Address:	Ron Gonzales	678-7616
E911 Street Naming/Signs:	Diane Shelton	678-7665
Tax Parcel Numbers:		678-7549
NCDOT (driveways/curb-cuts):	Gary Burton	486-1496

NCDOT (*subdivision roads*):
Transportation Planning:
N.C. Division of Water Quality:
County Schools Planner:

David Plummer
Bobby McCormick
Mike Randall
Mark Whitley

486-1496
678 7632
(919) 733-5083 ext. 545
678-2342



COUNTY of CUMBERLAND

Planning & Inspections Department

CASE #: PO9-06

PLANNING BOARD
MEETING DATE: 17 MAR 09

DATE APPLICATION
SUBMITTED: 3 FEB 09

RECEIPT #: 60522

RECEIVED BY: PBB

APPLICATION FOR CONDITIONAL USE DISTRICT & PERMIT REZONING REQUEST CUMBERLAND COUNTY ZONING ORDINANCE

Upon receipt of this application (petition), the Planning and Inspections Staff will present to the Planning Board the application at a hearing. In accordance with state law and Board's policy, a notice of the hearing will be mailed to the owners of the adjacent and surrounding properties, which may be affected by the proposed Conditional Use.

The Planning Board will make a recommendation to the Cumberland County Board of Commissioners concerning the request. The Board of Commissioners will schedule a public hearing and make a final decision on the matter. Generally, the Commissioners will hold a public hearing four weeks following the meeting of the Planning Board. The Conditional Use District and Permit shall not be made effective until the request is heard and received approval by the Board of Commissioners.

The following items are to be submitted with the completed application:

1. A copy of the recorded deed and/or plat;
2. If a portion of an existing tract, an accurate written legal description of only the area to be considered for rezoning;
3. A copy of a detailed site plan drawn to engineering scale, showing the location of all buildings, yard dimensions, driveways, fencing, lighting parking areas, landscaping, and all other pertinent data to the case; ^{\$500.00} Fees applied from withdrawn case #
4. A check made payable to "Cumberland County" in the amount of \$800.00 (See attached Fee Schedule). PO9-03

NOTE: Any revisions, inaccuracies or errors to the application or site plan may cause the case to be delayed and will be scheduled for the next available Board meeting according to the Board's meeting schedule. Also, the application fee is *nonrefundable*.

The Planning and Inspections Staff is available for advice on completing this application; however, they are not available for completion of the application or preparation of the site plan.

TO THE CUMBERLAND COUNTY JOINT PLANNING BOARD AND THE BOARD OF COUNTY COMMISSIONERS OF CUMBERLAND COUNTY, NC:

I (We), the undersigned, hereby submit this application, and petition the County Commissioners to amend and to change the zoning map of the County of Cumberland as provided for under the provisions of the County Zoning Ordinance. In support of this petition, as hereinafter requested, the following facts are submitted:

1. APPLICANT/AGENT: JOHN KOENIG
2. ADDRESS: 1763 WILMINGTON HWY FAYETTEVILLE, N.C. ZIP CODE: 28306
3. TELEPHONE: (Home) 910-323-2506 (Work) 910-391-2977
4. Location of Property: ANDREWS ROAD
5. Parcel Identification Number (PIN #) of subject property: 0531-00-6612
(also known as Tax ID Number or Property Tax ID)
6. ✓ Acreage: 99.63 Frontage: 3871.19 Depth: 1056'
7. Water Provider: PWC
8. Septage Provider: PWC
9. Deed Book 7898, Page(s) 325, Cumberland County Registry. (Attach copy of deed of subject property as it appears in Registry).
10. Existing use of property: PND WOODLANDS
11. Proposed use(s) of the property: MIXED USE

O.I. - RESIDENTIAL SINGLE FAMILY - MULTI-FAMILY - GREENSPACE verbal
NOTE: Be specific and list all intended uses.

12. It is requested that the foregoing property be rezoned FROM: ~~PND~~ PND *Blp? → OK to add to application Per J. Koenig*

- TO: (select one)
- Conditional Use District, with an underlying zoning district of _____ (Article V)
 - Mixed Use/Conditional Use District (Article VI)
 - Planned Neighborhood District/Conditional Use District (Article VII)
 - Density Development/Conditional Use District, at the _____ Density (Article VIII)

INCLUDE PORTION OF: 0530-39-4583 → LOCATED ABOVE THE PROPOSED I-295 IN THE NE CORNER

APPLICATION FOR
CONDITIONAL USE PERMIT

1. PROPOSED USE(S):

- A. List the use(s) proposed for the Conditional Use Permit. (Use of the underlying district will be restricted only to the use(s) specified in this application.)

See attached site plan

- B. Density: List the amount of acreage that will be residential, commercial, and/or open space, and the number of lots and/or dwelling units proposed, and the square footage of the non-residential units.

See attached site plan

2. DIMENSIONAL REQUIREMENTS:

- A. Reference either the dimensional requirements of the district, Sec. 1104 or list the proposed setbacks.

See attached site plan

- B. Off-street parking and loading, Sec. 1202: List the number of spaces, type of surfacing material and any other pertinent information.

See attached site plan

3. SIGN REQUIREMENTS:

Reference the district sign regulations proposed from Article XIII.

Site plan

4. LANDSCAPE AND BUFFER REQUIREMENTS:

- A. For all new non-residential and mixed use development abutting a public street, indicate the number and type of large or small ornamental trees used in the streetscape, yard space, and/or parking areas, plus the number and type of shrubs (Sec. 1102N). **NOTE: All required landscaping must be included on the site plan.**

Site plan

- B. Indicate the type of buffering and approximate location, width and setback from the property lines.

Site plan

5. MISCELLANEOUS:

List any information not set forth above, such as the days and hours of the operation, number of employees, exterior lighting, noise, odor and smoke, emission controls, etc.

6. SITE PLAN REQUIREMENTS:

The application shall include a site plan drawn to the specifications of Sec. 1402. If the proposed uses involve development subject to the County Subdivision Ordinance, the site plan required may be general in nature, showing a generalized street pattern, if applicable, and the location of proposed uses. If the proposed uses include development not subject to the Subdivision Ordinance, the site plan shall be of sufficient detail to allow the Planning and Inspections Staff and the Planning Board to analyze the proposed uses and arrangement of uses on the site. It shall also include the footprints of all buildings (proposed and existing), the proposed number of stories, location and number of off-street parking and loading spaces, proposed points of access to existing streets and internal circulation patterns. In addition, the location of all proposed buffers and fences and landscaping shall be included on the site plan.

7. ACKNOWLEDGEMENT:

It is understood by the undersigned that the official zoning map, as originally adopted and subsequently amended, is presumed to be appropriate to the property involved and that the burden of proof for a zoning amendment (change) rests with the petitioner.

It is the responsibility of the petitioner (personally or by agent) to submit to the Planning and Inspections Department a valid request, not incompatible with existing neighborhood zoning patterns.

In order for the Planning Board to offer a favorable recommendation, and for the Board of Commissioners to approve, any Conditional Use District and Permit they must find from the evidence presented at their respective public hearing that:

- A. The use will not materially endanger the public health or safety if located according to the plan submitted and recommended;
- B. The use meets all required conditions and specifications;
- C. The use will maintain or enhance the value of adjoining or abutting properties, or that the use is a public necessity; and
- D. The location and character of the use, if developed according to the plan as submitted and recommended, will be in harmony with the area in which it is to be located and in general conformity with Cumberland County's most recent Comprehensive Land Use Plan and adopted planning policies.

I further understand I must voluntarily agree to all conditions proposed for the Conditional Use Permit.

The undersigned hereby acknowledge that the Planning and Inspections Staff has conferred with the petitioner or assigns, and the application as submitted is accurate and correct.

ANDREWS ROAD COMPANY LLC
NAME OF OWNERS (PRINT OR TYPE)

P.O. Box 87009 FAYETTEVILLE, N.C. 28304
ADDRESS OF OWNER(S)

910-323-2506
HOME TELEPHONE #

910-391-2977
WORK TELEPHONE #

SIGNATURE OF OWNER(S)

SIGNATURE OF OWNER(S)

ALFRED E. CLEVELAND, ATTORNEY AND GENERAL MANAGER
NAME OF AGENT, ATTORNEY, APPLICANT (by assign) (PRINT OR TYPE)

P.O. Box 87009 FAYETTEVILLE, N.C. 28304
ADDRESS OF AGENT, ATTORNEY, APPLICANT

HOME TELEPHONE #

910-483-8104
WORK TELEPHONE #

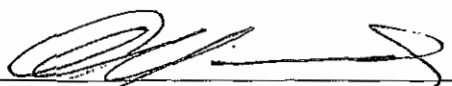

SIGNATURE OF AGENT, ATTORNEY
OR APPLICANT

- * **ALL record property owners must sign this petition.**
- * **The contents of this application, upon submission, becomes "public record."**

**CUMBERLAND COUNTY ZONING ORDINANCE
FEE SCHEDULE**

REQUESTED ZONING DISTRICTS ¹	LESS THAN 5 ACRES	5 TO 50 ACRES	50 TO 100 ACRES	100+ ACRES
CONDITIONAL USE DISTRICTS ² RESIDENTIAL DD/CUD	\$500	\$500	\$500	\$500
CONDITIONAL USE DISTRICTS ² NONRESIDENTIAL PND/CUD MXD/CUD	\$700	\$800	\$800	\$800

- 1 If more than one zoning district is requested in the same application, the highest fee for the district requested will apply.
- 2 If a general rezoning is requested and based on recommendations of the Planning Board or County Commissioners, the applicant desires to submit a Conditional Use District and Permit application, the original application fee will be credited towards the Conditional Use District and Permit application fee.

MOTIONS ON CONDITIONAL USE DISTRICT REZONING APPLICATIONS

IF TO APPROVE CONDITIONAL USE **DISTRICT**:

I MOVE THAT THE BOARD OF COMMISSIONERS FINDS THAT THIS CONDITIONAL USE DISTRICT APPLICATION IS REASONABLE, NEITHER ARBITRARY NOR UNDULY DISCRIMINATORY, AND IN THE PUBLIC INTEREST, AND THAT THE CONDITIONAL USE(S) BE APPROVED OR DELETED AS DESCRIBED IN THE STAFF AGENDA MEMORANDUM:

IF TO DENY CONDITIONAL USE **DISTRICT**:

I MOVE THAT THE BOARD OF COMMISSIONERS FAILS TO FIND THAT THIS CONDITIONAL USE DISTRICT APPLICATION IS REASONABLE, NEITHER ARBITRARY NOR UNDULY DISCRIMINATORY, AND IN THE PUBLIC INTEREST, AND THAT IT THEREFORE BE DENIED.

[*IF CONDITIONAL USE DISTRICT IS DENIED, DO NOT MAKE ANY MOTION ON CONDITIONAL USE PERMIT].**

IF TO APPROVE CONDITIONAL USE **PERMIT**:

I MOVE THAT THE BOARD OF COMMISSIONERS FINDS THAT THIS CONDITIONAL USE PERMIT APPLICATION, IF COMPLETED AS PROPOSED AND SUBJECT TO THE CONDITIONS RECOMMENDED BY THE PLANNING BOARD:

- (I) WILL NOT MATERIALLY ENDANGER THE PUBLIC HEALTH AND SAFETY, AND
- (II) WILL NOT SUBSTANTIALLY INJURE THE VALUE OF ADJOINING OR ABUTTING PROPERTY, AND
- (III) WILL BE IN HARMONY WITH THE AREA IN WHICH IT IS TO BE LOCATED, AND
- (IV) WILL BE IN CONFORMITY WITH THE LAND USE PLAN, THOROUGHFARE PLAN OR OTHER PLAN OFFICIALLY ADOPTED BY THE BOARD OF COMMISSIONERS.

October 22, 2007

**AFFIDAVIT OF THE HOUSING INSPECTOR'S REPORT
BEFORE THE BOARD OF CUMBERLAND COUNTY COMMISSIONERS**

I, Kim Reeves, Code Enforcement Officer for the County of Cumberland Planning & Inspection Department, acting in my official capacity, being duly sworn, depose and say:

BACKGROUND: That the following is a report on Minimum Housing Case Number MH5632-2008

Property Owners: Willie B. & Rosalyn Y. Shaw

Property Address: 2301 Enloe Street, Fayetteville, NC

Tax Parcel Identification Number: 0416-81-8119

SYNOPSIS: This property was inspected on August 29, 2008. All property owners and parties of interest were legally served the Notice of Violations and afforded a Hearing on October 1, 2008. No one attended the Hearing. It was ordered that the structure be repaired to a minimum standard for human habitation, or be demolished and the debris removed from the premises no later than December 1, 2008. The property owners and parties of interest were notified of the appeal procedures when they were served with the Findings of Fact and Order. (See Exhibit A for the Findings of Fact and Order.) No Appeal was filed. Upon my visit to the property on April 9, 2009, no corrective action has been made to the structure. The structure is presently vacant (and has been vacant since January, 2005) and unsecured. In it's present state, this structure constitutes a fire, health, and safety hazard. The estimated cost to repair the structure to a minimum standard for human habitation is \$65,000.00. The Assessor for Cumberland County has this structure presently valued at \$17,619.00. Attached is a map depicting the location of the property. (See Exhibit B.)

RECOMMENDATION: IT IS THE RECOMMENDATION OF THE PLANNING & INSPECTION DEPARTMENT THAT THIS STRUCTURE BE DEMOLISHED, THE INGROUND POOL BE ELIMINATED AND THE DEBRIS REMOVED FROM THE LOT.

Kim Reeves
Kim Reeves, Affiant
Code Enforcement Officer/County of Cumberland

Sworn to and Subscribed to by me this
the 5th day of April 2009.

Charisse Brown
Notary Public

CHARISSE BROWN
Notary Public
Cumberland County
State of North Carolina
My Commission Expires Sep 29, 2012

My Commission Expires: 09/29/2012.

**BOARD FINDINGS AND ACTION CHECK LIST
MINIMUM HOUSING REHABILITATION AND/OR DEMOLITION ORDINANCE**

Name(s) of Owner(s)

Appearances:

Inspection Dept. Case No.:

BOARD OF COUNTY COMMISSIONERS MOTION:

1. If the Board feels that the structure should be demolished, the Board's motion should be:

To adopt the order and report of the Minimum Housing Inspector as the true facts in this case, and

To order the property owner to remove or demolish the dwelling within _____ days.

To order the Inspector to remove or demolish the dwelling, if the owner fails to do so and impose a lien on the real property for the cost of such action.

To direct the clerk to incorporate the foregoing findings and orders in an ordinance certified by the Chairman and record the same in the Register of Deeds.

2. **If the Board feels that the property can be rehabilitated, the Board's motion should be:**

To adopt the order and report of the Minimum Housing Inspector as the true facts in this case.

To order the property owner to rehabilitate the property within _____ days.

To order the property owner to vacate and secure the property within _____ days pending rehabilitation.

To order the Inspector to rehabilitate the property or remove or demolish the dwelling, if the owner fails to do so and impose a lien on the real property for the cost of such action.

To direct the clerk to incorporate the foregoing findings and orders in an ordinance certified by the Chairman and record the same in the Register of Deeds.

3. **If the Board wishes to delay action on the case, the Board's motion should be:**

To adopt the order and report of the Minimum Housing Inspector as the true facts in this case.

To delay a decision on the case until _____ (date) in order to give the owner or party of interest time to: _____

4. In addition there is imposed a civil penalty in the amount of \$ _____ per day (up to a maximum amount of \$3,000.00) for failure to comply with the terms of this Ordinance.

Donovan McLaurin,
Chair
Wade, Falcon & Godwin

Lori Epler,
Vice-Chair
Cumberland County

Garland C. Hostetter,
Town of Spring Lake
Harvey Cain, Jr.,
Town of Stedman
Patricia Hall,
Town of Hope Mills
Charles C. Morris,
Town of Linden



Thomas J. Lloyd,
Director

Cecil P. Combs,
Deputy Director

Walter Clark,
Roy Turner,
Sara E. Piland,
Cumberland County

Benny Pearce,
Town of Eastover

COUNTY of CUMBERLAND

Planning & Inspections Department

FINDINGS OF FACT AND ORDER

October 6, 2008

CASE #: MH 5632-2008

TO: Willie Bernard & Rosalyn Yvonne Shaw Sr. & Parties of Interest
51 Dixon Lane
Southport, NC 28461

Property at: 2301 Enloe Street, Fayetteville, NC

A Complaint, Notice of Hearing and Report of Inspection were legally served to the owner or owner's agent, and any party of interest. These documents were in fact received by the owner or owner's agent and party of interest on 9/16/2008.

Pursuant of law, a Hearing was conducted in Room 101, of the old courthouse at 130 Gillespie Street, Fayetteville, NC on 10/1/2008 at 9:30:00 AM. The items identified below took place at the Hearing:

- 1. No owner or party of interest, or their agent, or representative appeared.
- 2. An answer was filed by owners and/or parties of interest. The answer was heard, read, and considered. Those present were: _____.
- 3. The undersigned inspector personally inspected the dwelling described in the Complaint and Notice of Hearing dated, 9/9/2008. Upon the record and all of the evidence offered and contentions made, the undersigned Hearing Officer does thereby find the following fact:
 - a. The dwelling in question is violative of the Cumberland County Housing Ordinance as per findings in the inspection report with an assigned case number of MH 5632-2008, dated 8/29/2008.
 - b. Due to these findings, the dwelling are found to be in a substandard condition in accordance with the Cumberland County Ordinance.
 - c. The dwelling is unfit for human habitation.

4. Due to facts presented above, the Hearing Officer orders as follows:
- a. The owners and/or parties of interest of the dwelling named above are required to bring such dwelling into compliance with the Cumberland County Housing Ordinance by either repairing, altering, and improving the dwelling up to a minimum standard or by demolishing the structure and then causing the debris to be removed from the premises by a date not later than **12/1/2008**. **All required permits must be obtained. A copy of this order must be presented when obtaining permits.**
 - b. The dwelling shall remain vacated until compliance with this order is completed and removed by the inspector, and the lot must be continuously maintained.
 - c. The structure shall be secured by **10/15/2008** and remained secured.
 - d. By authority of North Carolina General Statutes 14-4, violation of the County code is punishable as a Class 3 Misdemeanor in criminal court and also subjects the violator to injunctive relief and/or a civil penalty of \$50.00 per day for each day's continuing violation after **10/15/2008** for failure to secure the dwelling.
 - e. The County Planning/Inspection Department may immediately begin procedures to seek a demolition ordinance from the Cumberland County Board of Commissioners for failure to bring the property into compliance by **12/1/2008**. The cost of said demolition will be assessed against the real property in the form of a lien.

An appeal may be made to the Cumberland County Housing Board of Appeals. If an appeal is requested, it must be made in writing and within the time limits specified in the enclosed appeal procedures.



Ken Sykes
Hearing Officer

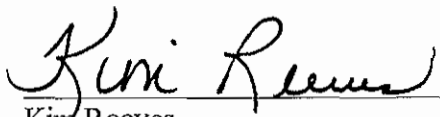

Kim Reeves
Code Enforcement Officer

Enclosed: Appeals Procedures & Form

cc:

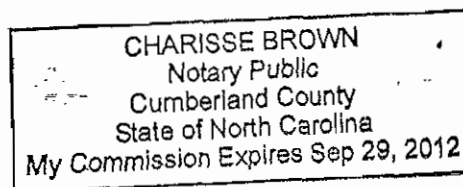

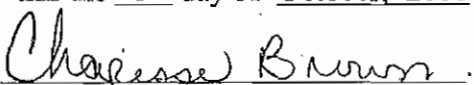
Sworn to and Subscribed to by me
this the 6th day of October, 2008

Notary Public
My Commission Expires: 9/29/2012

**PROOF OF LEGAL SERVICE OF FINDINGS OF FACT & ORDER
DATED OCTOBER 6, 2008
MINIMUM HOUSING CASE NUMBER: MH5632-2008
PROPERTY OWNERS: WILLIE B. & ROSALYN Y. SHAW**



[Home](#) | [Help](#)

[Track & Confirm](#)

Track & Confirm

Search Results *Willie B. SHAW*

Label/Receipt Number: **9171 0821 3339 3597 3410 63**
Status: **Delivered**

Your item was delivered at 1:49 pm on October 29, 2008 in SOUTHPORT, NC 28461. A proof of delivery record may be available through your local Post Office for a fee.

Additional information for this item is stored in files offline.

[Track & Confirm](#)

Enter Label/Receipt Number.



[Home](#) | [Help](#)

[Track & Confirm](#)

Track & Confirm

Search Results *ROSALYN Y. SHAW*

Label/Receipt Number: **9171 0821 3339 3597 3410 70**
Status: **Delivered**

Your item was delivered at 1:49 pm on October 29, 2008 in SOUTHPORT, NC 28461. A proof of delivery record may be available through your local Post Office for a fee.

Additional information for this item is stored in files offline.

[Track & Confirm](#)

Enter Label/Receipt Number.

[Restore Offline Details >](#)



[Return to USPS.com Home >](#)

EXHIBIT A

MAP DEPICTING LOCATION OF PROPERTY

2301 ENLOE STREET, FAYETTEVILLE, NC
OWNERS: WILLIE B. & ROSALYN Y. SHAW
MINIMUM HOUSING CASE NUMBER: MH5632-2008
PARCEL IDENTIFICATION #: 0416-81-8119

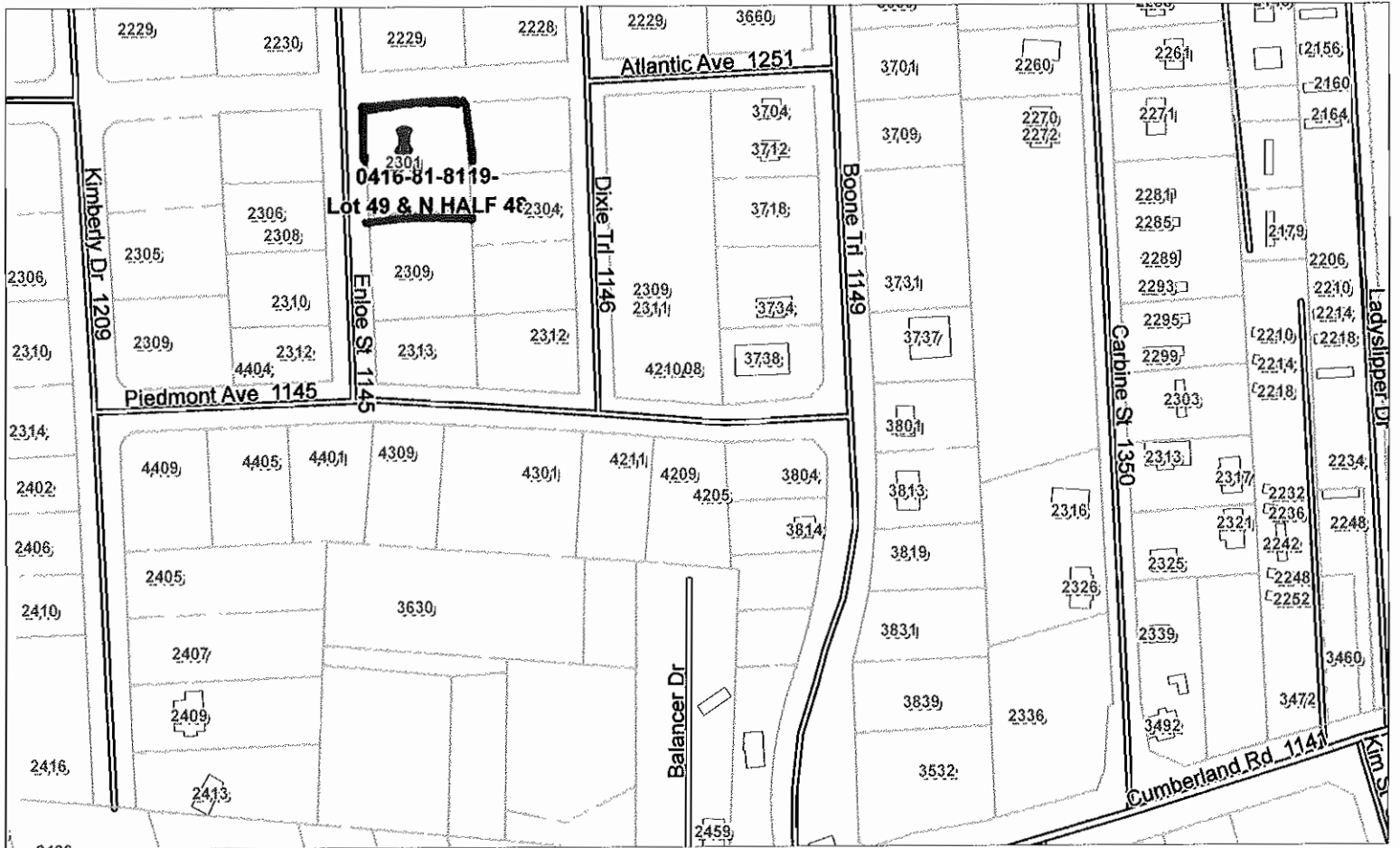

**AFFIDAVIT OF THE HOUSING INSPECTOR'S REPORT
BEFORE THE BOARD OF CUMBERLAND COUNTY COMMISSIONERS**

I, Kim Reeves, Code Enforcement Officer for the County of Cumberland Planning & Inspection Department, acting in my official capacity, being duly sworn, depose and say:

BACKGROUND: That the following is a report on Minimum Housing Case Number MH5666-2008

Property Owners: Luther & Catherine Whitehead

Property Address: 7635 Cannery Drive, Dunn, NC (Cumberland County)

Tax Parcel Identification Number: **1504-60-7465**

SYNOPSIS: This property was inspected on September 29, 2008. All property owners and parties of interest were legally served the Notice of Violations and afforded a Hearing on November 12, 2008. Catherine Stewart and Frederick Carpenter attended the Hearing. It was ordered that the structure be repaired to a minimum standard for human habitation, or be demolished and the debris removed from the premises no later than January 12, 2009. The property owners and parties of interest were notified of the appeal procedures when they were served with the Findings of Fact and Order. (See Exhibit A for the Findings of Fact and Order.) No Appeal was filed. Upon my visit to the property on April 9, 2009, no corrective action has been made to the structure. The structure is presently destroyed by fire, vacant and unsecured. In it's present state, this structure constitutes a fire, health, and safety hazard. The estimated cost to repair the structure to a minimum standard for human habitation is \$50,000.00. The Assessor for Cumberland County has this structure presently valued at \$812.00. Attached is a map depicting the location of the property. (See Exhibit B.)

RECOMMENDATION: IT IS THE RECOMMENDATION OF THE PLANNING & INSPECTION DEPARTMENT THAT THIS STRUCTURE BE DEMOLISHED, AND THE DEBRIS REMOVED FROM THE LOT.

Kim Reeves
Kim Reeves, Affiant
Code Enforcement Officer/County of Cumberland

Sworn to and Subscribed to by me this
the 8th day of April 2009.
Charisse Brown
Notary Public

CHARISSE BROWN
Notary Public
Cumberland County
State of North Carolina
My Commission Expires Sep 20, 2012

My Commission Expires: 09/29/2012.

**BOARD FINDINGS AND ACTION CHECK LIST
MINIMUM HOUSING REHABILITATION AND/OR DEMOLITION ORDINANCE**

Name(s) of Owner(s)

Appearances:

Inspection Dept. Case No.:

BOARD OF COUNTY COMMISSIONERS MOTION:

1. If the Board feels that the structure should be demolished, the Board's motion should be:

To adopt the order and report of the Minimum Housing Inspector as the true facts in this case,
and

To order the property owner to remove or demolish the dwelling within _____ days.

To order the Inspector to remove or demolish the dwelling, if the owner fails to do so and
impose a lien on the real property for the cost of such action.

To direct the clerk to incorporate the foregoing findings and orders in an ordinance certified by
the Chairman and record the same in the Register of Deeds.

2. **If the Board feels that the property can be rehabilitated, the Board's motion should be:**

To adopt the order and report of the Minimum Housing Inspector as the true facts in this case.

To order the property owner to rehabilitate the property within _____ days.

To order the property owner to vacate and secure the property within _____ days
pending rehabilitation.

To order the Inspector to rehabilitate the property or remove or demolish the dwelling, if the
owner fails to do so and impose a lien on the real property for the cost of such action.

To direct the clerk to incorporate the foregoing findings and orders in an ordinance certified by
the Chairman and record the same in the Register of Deeds.

3. **If the Board wishes to delay action on the case, the Board's motion should be:**

To adopt the order and report of the Minimum Housing Inspector as the true facts in this case.

To delay a decision on the case until _____ (date) in order to give the owner
or party of interest time to: _____

4. In addition there is imposed a civil penalty in the amount of \$ _____ per day (up to
a maximum amount of \$3,000.00) for failure to comply with the terms of this Ordinance.

Donovan McLaurin,
Chair
Wade, Falcon & Godwin

Lori Epler,
Vice-Chair
Cumberland County

Garland C. Hostetter,
Town of Spring Lake
Harvey Cain, Jr.,
Town of Stedman
Patricia Hall,
Town of Hope Mills
Charles C. Morris,
Town of Linden



Thomas J. Lloyd,
Director

Cecil P. Combs,
Deputy Director

Clifton McNeill, Jr.,
Roy Turner,
Sara E. Piland,
Cumberland County

COUNTY of CUMBERLAND

Planning and Inspections Department

FINDINGS OF FACT AND ORDER

November 12, 2008

CASE #: MH 5666-2008

TO: Luther & Catherine Whitehead & Parties of Interest
25 Crest Circle
Spring Lake, NC 28390

Property at: 7635 Cannery Drive, Dunn, NC

A Complaint, Notice of Hearing and Report of Inspection were legally served to the owner or owner's agent, and any party of interest. These documents were in fact received by the owner or owner's agent and party of interest on 10/23/2008.

Pursuant of law, a Hearing was conducted in Room 101, of the old courthouse at 130 Gillespie Street, Fayetteville, NC on 11/12/2008 at 9:45:00 AM. The items identified below took place at the Hearing:

- 1. No owner or party of interest, or their agent, or representative appeared.
- 2. An answer was filed by owners and/or parties of interest. The answer was heard, read, and considered. Those present were: Catherine Stewart, Frederick Carpenter, Joey Lewis, and Kim Reeves.
- 3. The undersigned inspector personally inspected the dwelling described in the Complaint and Notice of Hearing dated, 10/21/2008. Upon the record and all of the evidence offered and contentions made, the undersigned Hearing Officer does thereby find the following fact:
 - a. The dwelling in question is violative of the Cumberland County Housing Ordinance as per findings in the inspection report with an assigned case number of MH 5666-2008, dated 9/29/2008.
 - b. Due to these findings, the dwelling are found to be in a substandard condition in accordance with the Cumberland County Ordinance.
 - c. The dwelling is unfit for human habitation.

- 4. Due to facts presented above, the Hearing Officer orders as follows:
 - a. The owners and/or parties of interest of the dwelling named above are required to bring such dwelling into compliance with the Cumberland County Housing Ordinance by either repairing, altering, and improving the dwelling up to a minimum standard or by demolishing the structure and then causing the debris to be removed from the premises by a date not later than 1/12/2009. **All required permits must be obtained. A copy of this order must be presented when obtaining permits.**
 - b. The dwelling shall remain vacated until compliance with this order is completed and removed by the inspector, and the lot must be continuously maintained.
 - c. The structure shall be/remain secured.
 - d. By authority of North Carolina General Statutes 14-4, violation of the County code is punishable as a Class 3 Misdemeanor in criminal court and also subjects the violator to injunctive relief and/or a civil penalty of \$50.00 per day for each day's continuing violation after _____.
 - e. The County Planning/Inspection Department may immediately begin procedures to seek a demolition ordinance from the Cumberland County Board of Commissioners for failure to bring the property into compliance by 1/12/2009. The cost of said demolition will be assessed against the real property in the form of a lien.

An appeal may be made to the Cumberland County Housing Board of Appeals. If an appeal is requested, it must be made in writing and within the time limits specified in the enclosed appeal procedures.

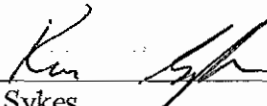

Ken Sykes
Hearing Officer

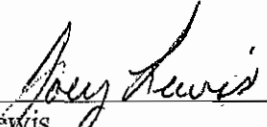

Joey Lewis
Code Enforcement Officer

Enclosed: Appeals Procedures & Form

cc:

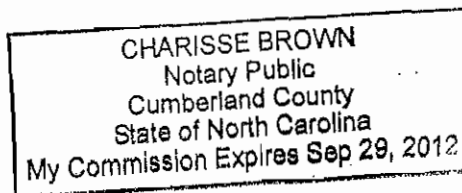

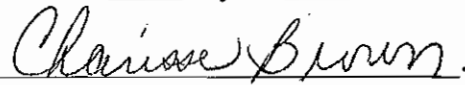
Sworn to and Subscribed to by me
this the 12th day of November, 2008

Notary Public
My Commission Expires: 9/29/2012

**PROOF OF LEGAL SERVICE OF FINDINGS OF FACT & ORDER
DATED NOVEMBER 12, 2008
MINIMUM HOUSING CASE NUMBER: MH5666-2008
PROPERTY OWNERS: LUTHER & CATHERINE WHITEHEAD**



[Home](#) | [Help](#) | [Sign In](#)

[Track & Confirm](#) [FAQs](#)

Track & Confirm

Search Results *LUTHER WHITEHEAD*

Label/Receipt Number: 9171 0821 3339 3550 3893 23
Status: Delivered

Your item was delivered at 10:54 am on November 14, 2008 in SPRING LAKE, NC 28390. A proof of delivery record may be available through your local Post Office for a fee.

Additional information for this item is stored in files offline.

[Restore Offline Details >](#)



[Return to USPS.com Home >](#)

Track & Confirm

Enter Label/Receipt Number.

[Go >](#)



[Home](#) | [Help](#) | [Sign In](#)

[Track & Confirm](#) [FAQs](#)

Track & Confirm

Search Results *CATHERINE WHITEHEAD*

Label/Receipt Number: 9171 0821 3339 3550 3893 30
Status: Delivered

Your item was delivered at 10:53 AM on November 14, 2008 in SPRING LAKE, NC 28390.

Information on this item has been restored from offline files and will be available online for 30 days from 04/07/2009.

[Additional Details >](#)

[Return to USPS.com Home >](#)

Track & Confirm

Enter Label/Receipt Number.

[Go >](#)

EXHIBIT A

MAP DEPICTING LOCATION OF PROPERTY

**7635 CANNERY DRIVE, DUNN, NC
OWNERS: LUTHER & CATHERINE WHITEHEAD
MINIMUM HOUSING CASE NUMBER: MH5666-2008
PARCEL IDENTIFICATION #: 1504-60-7465**

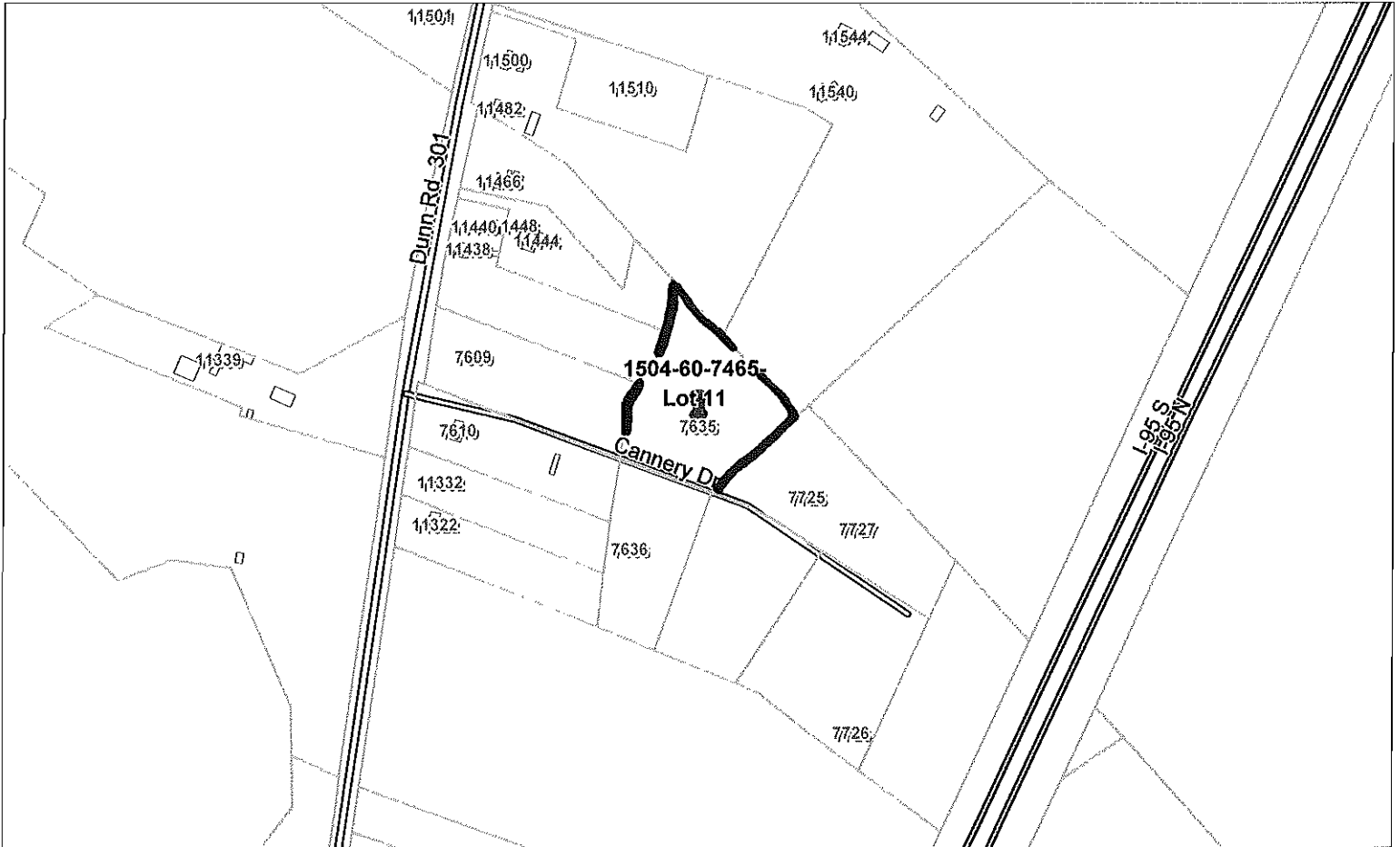

EXHIBIT B

**AFFIDAVIT OF THE HOUSING INSPECTOR'S REPORT
BEFORE THE BOARD OF CUMBERLAND COUNTY COMMISSIONERS**

I, George Hatcher, Code Enforcement Officer for the County of Cumberland Planning & Inspection Department, acting in my official capacity, being duly sworn, depose and say:

BACKGROUND: That the following is a report on Minimum Housing Case Number MH5565-2008

Property Owners: Beulah H. Gerhart, Michael D. Canady and Peggy T. Canady

Property Address: 5136 Matt Hair Road, Fayetteville, NC

Tax Parcel Identification Number: 0452-92-5181

SYNOPSIS: This property was inspected on July 8, 2008. All property owners and parties of interest were legally served the Notice of Violations and afforded a Hearing on August 14, 2008 . Michael Canady **attended** the Hearing. It was ordered that the structure be repaired to a minimum standard for human habitation, or be demolished and the debris removed from the premises no later than November 14, 2008. The property owners and parties of interest were notified of the appeal procedures when they were served with the Findings of Fact and Order. (See Exhibit A for the Findings of Fact and Order.) No Appeal was filed. Upon my visit to the property on April 9, 2009, no corrective action has been made to the structure. The structure is presently vacant and reasonably secured. In it's present state, this structure constitutes a fire, health, and safety hazard. The estimated cost to repair the structure to a minimum standard for human habitation is \$15,000.00. The Assessor for Cumberland County has this structure presently valued at \$500.00. Attached is a map depicting the location of the property. (See Exhibit B.)

RECOMMENDATION: IT IS THE RECOMMENDATION OF THE PLANNING & INSPECTION DEPARTMENT THAT THIS STRUCTURE BE DEMOLISHED, AND THE DEBRIS REMOVED FROM THE LOT.

George Hatcher
George Hatcher, Affiant
Code Enforcement Officer/County of Cumberland

Sworn to and Subscribed to by me this
the 9th day of April 2009.
Charisse Brown
Notary Public

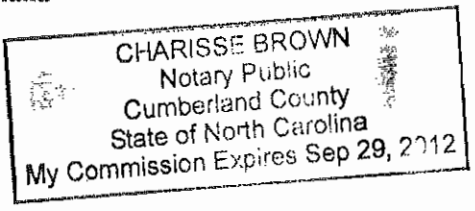

My Commission Expires: 09/29/2012.

**BOARD FINDINGS AND ACTION CHECK LIST
MINIMUM HOUSING REHABILITATION AND/OR DEMOLITION ORDINANCE**

Name(s) of Owner(s)

Appearances:

Inspection Dept. Case No.:

BOARD OF COUNTY COMMISSIONERS MOTION:

1. If the Board feels that the structure should be demolished, the Board's motion should be:

To adopt the order and report of the Minimum Housing Inspector as the true facts in this case, and

To order the property owner to remove or demolish the dwelling within _____ days.

To order the Inspector to remove or demolish the dwelling, if the owner fails to do so and impose a lien on the real property for the cost of such action.

To direct the clerk to incorporate the foregoing findings and orders in an ordinance certified by the Chairman and record the same in the Register of Deeds.

2. **If the Board feels that the property can be rehabilitated, the Board's motion should be:**

To adopt the order and report of the Minimum Housing Inspector as the true facts in this case.

To order the property owner to rehabilitate the property within _____ days.

To order the property owner to vacate and secure the property within _____ days pending rehabilitation.

To order the Inspector to rehabilitate the property or remove or demolish the dwelling, if the owner fails to do so and impose a lien on the real property for the cost of such action.

To direct the clerk to incorporate the foregoing findings and orders in an ordinance certified by the Chairman and record the same in the Register of Deeds.

3. **If the Board wishes to delay action on the case, the Board's motion should be:**

To adopt the order and report of the Minimum Housing Inspector as the true facts in this case.

To delay a decision on the case until _____ (date) in order to give the owner or party of interest time to: _____

4. In addition there is imposed a civil penalty in the amount of \$ _____ per day (up to a maximum amount of \$3,000.00) for failure to comply with the terms of this Ordinance.

Donovan McLaurin,
Chair
Wade, Falcon & Godwin

Lori Epler,
Vice-Chair
Cumberland County

Garland C. Hostetter,
Town of Spring Lake
Harvey Cain, Jr.,
Town of Stedman
Patricia Hall,
Town of Hope Mills
Charles C. Morris,
Town of Linden



Thomas J. Lloyd,
Director

Cecil P. Combs,
Deputy Director

Walter Clark,
Roy Turner,
Sara E. Piland,
Cumberland County

Benny Pearce,
Town of Eastover

COUNTY of CUMBERLAND

Planning & Inspections Department

FINDINGS OF FACT AND ORDER

August 14, 2008

CASE #: MH 5565-2008

TO: Beulah H. Gerhart & Parties of Interest & Michael D. & Peggy T. Canady
2767 Oceanview Avenue 5126 Matt Hair Road
Supply, NC 28462 Fayetteville, NC 28312

Property at: 5136 Matt Hair Road, Fayetteville, NC

A Complaint, Notice of Hearing and Report of Inspection were legally served to the owner or owner's agent, and any party of interest. These documents were in fact received by the owner or owner's agent and party of interest on 7/18/2008.

Pursuant of law, a Hearing was conducted in Room 101, of the old courthouse at 130 Gillespie Street, Fayetteville, NC on 8/14/2008 at 10:00:00 AM. The items identified below took place at the Hearing:

- 1. No owner or party of interest, or their agent, or representative appeared.
- 2. An answer was filed by owners and/or parties of interest. The answer was heard, read, and considered. Those present were: Michael Canady via telephone.
- 3. The undersigned inspector personally inspected the dwelling described in the Complaint and Notice of Hearing dated, 7/16/2008. Upon the record and all of the evidence offered and contentions made, the undersigned Hearing Officer does thereby find the following fact:
 - a. The dwelling in question is violative of the Cumberland County Housing Ordinance as per findings in the inspection report with an assigned case number of MH 5565-2008 dated 7/8/2008.
 - b. Due to these findings, the dwelling are found to be in a substandard condition in accordance with the Cumberland County Ordinance.
 - c. The dwelling is unfit for human habitation.

EXHIBIT "A"

- 4. Due to facts presented above, the Hearing Officer orders as follows:
 - a. The owners and/or parties of interest of the dwelling named above are required to bring such dwelling into compliance with the Cumberland County Housing Ordinance by either repairing, altering, and improving the dwelling up to a minimum standard or by demolishing the structure and then causing the debris to be removed from the premises by a date not later than **11/14/2008**. **A professional engineer or architect must determine what corrective measures will be required to bring the unit into compliance. All required permits must be obtained. A copy of this order must be presented when obtaining permits.**
 - b. The dwelling shall remain vacated until compliance with this order is completed and removed by the inspector, and the lot must be continuously maintained.
 - c. The structure shall be/remain secured.
 - d. By authority of North Carolina General Statutes 14-4, violation of the County code is punishable as a Class 3 Misdemeanor in criminal court and also subjects the violator to injunctive relief and/or a civil penalty of \$50.00 per day for each day's continuing violation after _____.
 - e. The County Planning/Inspection Department may immediately begin procedures to seek a demolition ordinance from the Cumberland County Board of Commissioners for failure to bring the property into compliance by **11/14/2008**. The cost of said demolition will be assessed against the real property in the form of a lien.

An appeal may be made to the Cumberland County Housing Board of Appeals. If an appeal is requested, it must be made in writing and within the time limits specified in the enclosed appeal procedures.

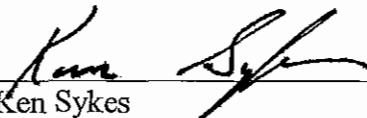

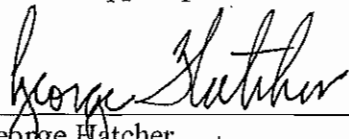
 Ken Sykes
 Hearing Officer

 George Hatcher
 Code Enforcement Officer

Enclosed: Appeals Procedures & Form

cc:

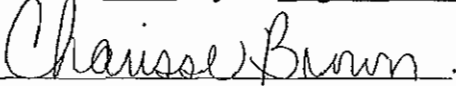
CHARISSE BROWN
 Notary Public
 Cumberland County
 State of North Carolina
 My Commission Expires Sep 29, 2012

Sworn to and Subscribed to by me
 this the 14th day of August, 2008

 Notary Public
 My Commission Expires: 9/29/2012

**PROOF OF SERVICE OF FINDINGS OF FACT AND ORDER
DATED 8/14/08 CASE NUMBER MH 5565-2008**

NORTH CAROLINA
COUNTY OF CUMBERLAND

PLANNING/INSPECTIONS DEPARTMENT

RE: BEULAH H. GERHART
Name of Violator

MH 5565-2008
Case Number

AFFIDAVIT OF RETURN OF SERVICE
(Personal Service to Individual)

I, George Hatcher, Code Enforcement Officer, with the Cumberland County Inspections Department,
(name & title)

personally served Beulah H. Gerhart & Michael D. & Peggy T. Canady a copy of the FINDINGS OF FACT AND ORDER
(name of violator)

AND, APPEALS PROCEDURES, citing violations of Article IV, CHAPTER 4 of the Cumberland County

Ordinance by mailing said notice(s) via 1st class mail and certified mail to the following address:

2767 Oceanview Avenue, Supply, NC 28462 & 5126 Matt Hair Road, Fayetteville, NC 28312

and by posting at: 5136 Matt Hairr Road, Fayetteville, NC.

I further certify that said service was completed on this the 18th day of AUGUST,
20 08.



George Hatcher
Code Enforcement Officer

Sworn to and subscribed to before me

this the 1st day of April, 2009.

Charisse Brown
Notary Public

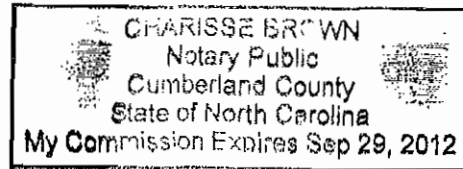
My Commission Expires: 9-29-12



**PROOF OF SERVICE OF FINDINGS OF FACT AND ORDER
DATED 8/14/08 CASE NUMBER MH 5565-2008**

SENDER: COMPLETE THIS SECTION	COMPLETE THIS SECTION ON DELIVERY	
<ul style="list-style-type: none"> Complete items 1, 2, and 3. Also complete item 4 if Restricted Delivery is desired. Print your name and address on the reverse so that we can return the card to you. Attach this card to the back of the mailpiece, or on the front if space permits. 	<p>A. Signature <input checked="" type="checkbox"/> Peggy Canady <input type="checkbox"/> Agent <input type="checkbox"/> Addressee</p> <p>B. Received by (Printed Name) C. Date of Delivery Peggy Canady 8-18-08</p> <p>D. Is delivery address different from item 1? <input type="checkbox"/> Yes If YES, enter delivery address below: <input type="checkbox"/> No</p>	
<p>1. Article Addressed to:</p> <p align="center">FOFO ZN5565GH</p> <p>MICHAEL D CANADY & PARTIES OF INTEREST 5126 MATT HAIR ROAD FAYETTEVILLE NC 28312</p>	<p>3. Service Type <input type="checkbox"/> Certified Mail <input type="checkbox"/> Express Mail <input type="checkbox"/> Registered <input type="checkbox"/> Return Receipt for Merchandise <input type="checkbox"/> Insured Mail <input type="checkbox"/> C.O.D.</p> <p>4. Restricted Delivery? (Extra Fee) <input type="checkbox"/> Yes</p>	
<p>2. Article Number (Transfer from service label)</p>	<p align="center">7003 0500 0004 7403 2935</p>	
<p>PS Form 3811, February 2004 Domestic Return Receipt 102595-02-M-1540</p>		

SENDER: COMPLETE THIS SECTION	COMPLETE THIS SECTION ON DELIVERY	
<ul style="list-style-type: none"> Complete items 1, 2, and 3. Also complete item 4 if Restricted Delivery is desired. Print your name and address on the reverse so that we can return the card to you. Attach this card to the back of the mailpiece, or on the front if space permits. 	<p>A. Signature <input checked="" type="checkbox"/> Peggy Canady <input type="checkbox"/> Agent <input type="checkbox"/> Addressee</p> <p>B. Received by (Printed Name) C. Date of Delivery Peggy Canady 8-18-08</p> <p>D. Is delivery address different from item 1? <input type="checkbox"/> Yes If YES, enter delivery address below: <input type="checkbox"/> No</p>	
<p>1. Article Addressed to:</p> <p align="center">FOFO ZN5565GH</p> <p>PEGGY T CANADY & PARTIES OF INTEREST 5126 MATT HAIR ROAD FAYETTEVILLE NC 28312</p>	<p>3. Service Type <input type="checkbox"/> Certified Mail <input type="checkbox"/> Express Mail <input type="checkbox"/> Registered <input type="checkbox"/> Return Receipt for Merchandise <input type="checkbox"/> Insured Mail <input type="checkbox"/> C.O.D.</p> <p>4. Restricted Delivery? (Extra Fee) <input type="checkbox"/> Yes</p>	
<p>2. Article Number (Transfer from service label)</p>	<p align="center">7003 0500 0004 7403 2928</p>	
<p>PS Form 3811, February 2004 Domestic Return Receipt 102595-02-M-1540</p>		

MAP DEPICTING LOCATION OF PROPERTY
Property Owner: Beulah Gerhart, Michael & Peggy Canady
5136 Matt Hairr Road, Fayetteville, NC
MINIMUM HOUSING CASE # MH 5565-2008
TAX PARCEL IDENTIFICATION NUMBER: 0452-92-5181



EXHIBIT B

**AFFIDAVIT OF THE HOUSING INSPECTOR'S REPORT
BEFORE THE BOARD OF CUMBERLAND COUNTY COMMISSIONERS**

I, George Hatcher, Code Enforcement Officer for the County of Cumberland Planning & Inspection Department, acting in my official capacity, being duly sworn, depose and say:

BACKGROUND: That the following is a report on Minimum Housing Case Number MH5551-2008

Property Owner: Carole B. Marshall Life Estate

Property Address: 6159 Butler Nursery Road, Fayetteville, NC

Tax Parcel Identification Number: 0451-08-0289

SYNOPSIS: This property was inspected on June 23, 2008. All property owners and parties of interest were legally served the Notice of Violations and afforded a Hearing on July 16, 2008. Carole B. Marshall **attended** the Hearing. It was ordered that the structure be repaired to a minimum standard for human habitation, or be demolished and the debris removed from the premises no later than October 16, 2008. The property owners and parties of interest were notified of the appeal procedures when they were served with the Findings of Fact and Order. (See Exhibit A for the Findings of Fact and Order.) No Appeal was filed. Upon my visit to the property on April 9, 2009, no corrective action has been made to the structure. The structure is presently vacant and unsecured. In it's present state, this structure constitutes a fire, health, and safety hazard. The estimated cost to repair the structure to a minimum standard for human habitation is \$50,000.00. The Assessor for Cumberland County has this structure presently valued at \$7,921.00. Attached is a map depicting the location of the property. (See Exhibit B.)

RECOMMENDATION: IT IS THE RECOMMENDATION OF THE PLANNING & INSPECTION DEPARTMENT THAT THIS STRUCTURE BE DEMOLISHED, AND THE DEBRIS REMOVED FROM THE LOT.



George Hatcher, Affiant
Code Enforcement Officer/County of Cumberland

Sworn to and Subscribed to by me this
the 8th day of April 2009.

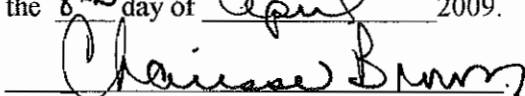

Notary Public

CHARISSE BROWN
Notary Public
Cumberland County
State of North Carolina
My Commission Expires Sep 29, 2012

My Commission Expires: 09/29/2012.

**BOARD FINDINGS AND ACTION CHECK LIST
MINIMUM HOUSING REHABILITATION AND/OR DEMOLITION ORDINANCE**

Name(s) of Owner(s)

Appearances:

Inspection Dept. Case No.:

BOARD OF COUNTY COMMISSIONERS MOTION:

1. If the Board feels that the structure should be demolished, the Board's motion should be:

To adopt the order and report of the Minimum Housing Inspector as the true facts in this case,
and

To order the property owner to remove or demolish the dwelling within _____ days.

To order the Inspector to remove or demolish the dwelling, if the owner fails to do so and
impose a lien on the real property for the cost of such action.

To direct the clerk to incorporate the foregoing findings and orders in an ordinance certified by
the Chairman and record the same in the Register of Deeds.

2. **If the Board feels that the property can be rehabilitated, the Board's motion should be:**

To adopt the order and report of the Minimum Housing Inspector as the true facts in this case.

To order the property owner to rehabilitate the property within _____ days.

To order the property owner to vacate and secure the property within _____ days
pending rehabilitation.

To order the Inspector to rehabilitate the property or remove or demolish the dwelling, if the
owner fails to do so and impose a lien on the real property for the cost of such action.

To direct the clerk to incorporate the foregoing findings and orders in an ordinance certified by
the Chairman and record the same in the Register of Deeds.

3. **If the Board wishes to delay action on the case, the Board's motion should be:**

To adopt the order and report of the Minimum Housing Inspector as the true facts in this case.

To delay a decision on the case until _____ (date) in order to give the owner
or party of interest time to: _____

4. In addition there is imposed a civil penalty in the amount of \$ _____ per day (up to
a maximum amount of \$3,000.00) for failure to comply with the terms of this Ordinance.

Donovan McLaurin,
Chair
Wade, Falcon & Godwin

Lori Epler,
Vice-Chair
Cumberland County

Garland C. Hostetter,
Town of Spring Lake
Harvey Cain, Jr.,
Town of Stedman
Patricia Hall,
Town of Hope Mills
Charles C. Morris,
Town of Linden

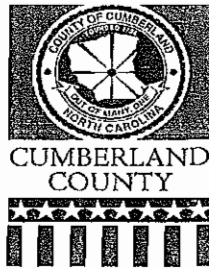

COUNTY of CUMBERLAND

Planning and Inspections Department

Thomas J. Lloyd,
Director

Cecil P. Combs,
Deputy Director

Clifton McNeill, Jr.,
Roy Turner,
Sara E. Piland,
Cumberland County

FINDINGS OF FACT AND ORDER

July 16, 2008

CASE #: MH 5551-2008

TO: Carole B. Marshall Life Estate & Parties of Interest
6243 Butler Nursery Road
Fayetteville, NC 28306

Property at: 6159/6243 Butler Nursery Road

A Complaint, Notice of Hearing and Report of Inspection were legally served to the owner or owner's agent, and any party of interest. These documents were in fact received by the owner or owner's agent and party of interest on 7/11/2008.

Pursuant of law, a Hearing was conducted in Room 101, of the old courthouse at 130 Gillespie Street, Fayetteville, NC on 7/16/2008 at 10:00:00 AM. The items identified below took place at the Hearing:

- 1. No owner or party of interest, or their agent, or representative appeared.
- 2. An answer was filed by owners and/or parties of interest. The answer was heard, read, and considered. Those present were: Carole B. Marshall.
- 3. The undersigned inspector personally inspected the dwelling described in the Complaint and Notice of Hearing dated, 6/24/2008. Upon the record and all of the evidence offered and contentions made, the undersigned Hearing Officer does thereby find the following fact:
 - a. The dwelling in question is violative of the Cumberland County Housing Ordinance as per findings in the inspection report with an assigned case number of MH 5551-2008, dated 6/23/2008.
 - b. Due to these findings, the dwelling are found to be in a substandard condition in accordance with the Cumberland County Ordinance.
 - c. The dwelling is unfit for human habitation.

- 4. Due to facts presented above, the Hearing Officer orders as follows:
 - a. The owners and/or parties of interest of the dwelling named above are required to bring such dwelling into compliance with the Cumberland County Housing Ordinance by either repairing, altering, and improving the dwelling up to a minimum standard or by demolishing the structure and then causing the debris to be removed from the premises by a date not later than **10/16/2008**. **All required permits must be obtained. A copy of this order must be presented when obtaining permits.**
 - b. The dwelling shall remain vacated until compliance with this order is completed and removed by the inspector, and the lot must be continuously maintained.
 - c. The structure shall be/remain secured.
 - d. By authority of North Carolina General Statutes 14-4, violation of the County code is punishable as a Class 3 Misdemeanor in criminal court and also subjects the violator to injunctive relief and/or a civil penalty of \$50.00 per day for each day's continuing violation after ____.
 - e. The County Planning/Inspection Department may immediately begin procedures to seek a demolition ordinance from the Cumberland County Board of Commissioners for failure to bring the property into compliance by **10/16/2008**. The cost of said demolition will be assessed against the real property in the form of a lien.

An appeal may be made to the Cumberland County Housing Board of Appeals. If an appeal is requested, it must be made in writing and within the time limits specified in the enclosed appeal procedures.

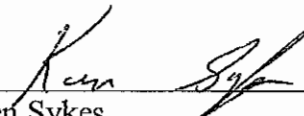

 Ken Sykes
 Hearing Officer

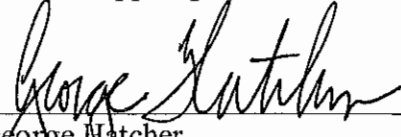

 George Natcher
 Code Enforcement Officer

Enclosed: Appeals Procedures & Form

cc:

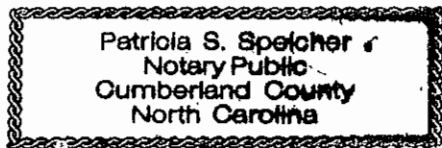

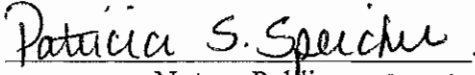
North Carolina
 Cumberland
 Sworn to and Subscribed to by me
 this the 16th day of July, 2008

 Notary Public 9-26-11
 My Commission Expires: 9/29/2012

PROOF OF SERVICE OF FINDINGS OF FACT AND ORDER

DATED 7/16/08 CASE NUMBER MH 5551-2008

RETURN TO:

NORTH CAROLINA
COUNTY OF CUMBERLAND

PLANNING/INSPECTION DEPARTMENT
OLD COURTHOUSE, ROOM 101
130 GILLESPIE STREET
FAYETTEVILLE, NC 28301

RE: CAROLE B. MARSHALL
Name of Violator

Case Number : MH 5551-2008

AFFIDAVIT OF RETURN OF SERVICE
(Personal Service to Individual)

I, GEORGE HATCHER a code enforcement officer with the Cumberland County Planning & Inspection Department, personally served CAROLE B. MARSHALL
name of violator

a copy of the FINDINGS OF FACT AND ORDER AND APPEALS PROCEDURES, citing violations of Article IV CHAP 4 of the Cumberland County Code by delivering said notice(s) to the violator at the address shown below:

130 GILLESPIE STREET
street name

FAYETTEVILLE, NC 28301

I further certify that said service was completed on this the 16 day of July, 2008.

George Hatcher
George Hatcher
Code Enforcement Officer

North Carolina
Cumberland County
Sworn to and subscribed to before me

this the 16th day of July, 2008.

Patricia S. Speicher
Notary Public

My Commission Expires: 9-26-11
9/29/12

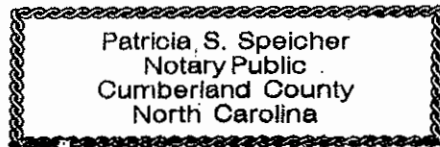

MAP DEPICTING LOCATION OF PROPERTY
Property Owner: Carole B Marshall
6159 Butler Nursery Road, Fayetteville, NC
MINIMUM HOUSING CASE # MH 5551-2008
TAX PARCEL IDENTIFICATION NUMBER: 0451-08-0289

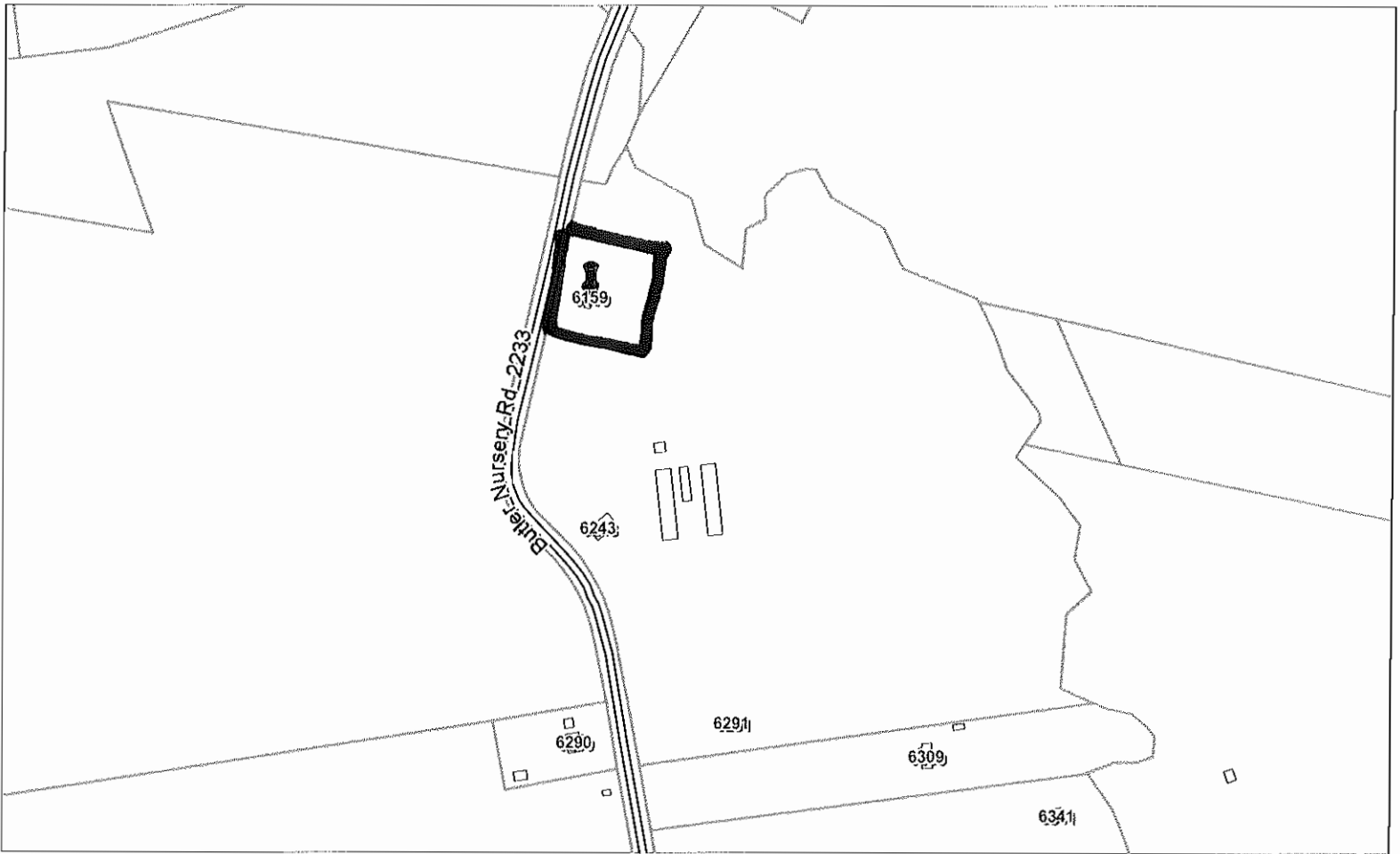

EXHIBIT B

**AFFIDAVIT OF THE HOUSING INSPECTOR'S REPORT
BEFORE THE BOARD OF CUMBERLAND COUNTY COMMISSIONERS**

I, George Hatcher, Code Enforcement Officer for the County of Cumberland Planning & Inspection Department, acting in my official capacity, being duly sworn, depose and say:

BACKGROUND: That the following is a report on Minimum Housing Case Number MH5703-2008

Property Owners: Alberta C. Baker Heirs

Property Address: 1828 Smith Road, Fayetteville, NC

Tax Parcel Identification Number: **0433-91-2146**

SYNOPSIS: This property was inspected on November 14, 2008. All property owners and parties of interest were legally served the Notice of Violations and afforded a Hearing on December 11, 2008 . James Baker **attended** the Hearing via telephone. It was ordered that the structure be repaired to a minimum standard for human habitation, or be demolished and the debris removed from the premises no later than February 11, 2009. The property owners and parties of interest were notified of the appeal procedures when they were served with the Findings of Fact and Order. (See Exhibit A for the Findings of Fact and Order.) No Appeal was filed. Upon my visit to the property on April 9, 2009, no corrective action has been made to the structure. The structure is presently vacant, unsecured and being occupied by vagrants. In it's present state, this structure constitutes a fire, health, and safety hazard. The estimated cost to repair the structure to a minimum standard for human habitation is \$20,000.00. The Assessor for Cumberland County has this structure presently valued at \$2,644.00. Attached is a map depicting the location of the property. (See Exhibit B.)

RECOMMENDATION: IT IS THE RECOMMENDATION OF THE PLANNING & INSPECTION DEPARTMENT THAT THIS STRUCTURE BE DEMOLISHED, AND THE DEBRIS REMOVED FROM THE LOT.

George Hatcher
George Hatcher, Affiant
Code Enforcement Officer/County of Cumberland

Sworn to and Subscribed to by me this
the 5th day of April 2009.

Chaisse Brown
Notary Public

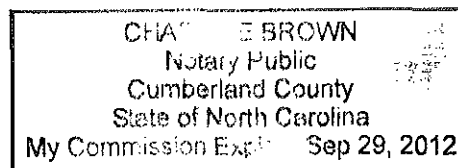

My Commission Expires: 09/29/2012.

BOARD FINDINGS AND ACTION CHECK LIST
MINIMUM HOUSING REHABILITATION AND/OR DEMOLITION ORDINANCE

Name(s) of Owner(s)

Appearances:

Inspection Dept. Case No.:

BOARD OF COUNTY COMMISSIONERS MOTION:

1. If the Board feels that the structure should be demolished, the Board's motion should be:

To adopt the order and report of the Minimum Housing Inspector as the true facts in this case,
and

To order the property owner to remove or demolish the dwelling within _____ days.

To order the Inspector to remove or demolish the dwelling, if the owner fails to do so and
impose a lien on the real property for the cost of such action.

To direct the clerk to incorporate the foregoing findings and orders in an ordinance certified by
the Chairman and record the same in the Register of Deeds.

2. **If the Board feels that the property can be rehabilitated, the Board's motion should be:**

To adopt the order and report of the Minimum Housing Inspector as the true facts in this case.

To order the property owner to rehabilitate the property within _____ days.

To order the property owner to vacate and secure the property within _____ days
pending rehabilitation.

To order the Inspector to rehabilitate the property or remove or demolish the dwelling, if the
owner fails to do so and impose a lien on the real property for the cost of such action.

To direct the clerk to incorporate the foregoing findings and orders in an ordinance certified by
the Chairman and record the same in the Register of Deeds.

3. **If the Board wishes to delay action on the case, the Board's motion should be:**

To adopt the order and report of the Minimum Housing Inspector as the true facts in this case.

To delay a decision on the case until _____ (date) in order to give the owner
or party of interest time to: _____

4. In addition there is imposed a civil penalty in the amount of \$ _____ per day (up to
a maximum amount of \$3,000.00) for failure to comply with the terms of this Ordinance.

Donovan McLaurin,
Chair
Wadé, Falcon & Godwin

Lori Epler,
Vice-Chair
Cumberland County

Garland C. Hostetter,
Town of Spring Lake
Harvey Cain, Jr.,
Town of Stedman
Patricia Hall,
Town of Hope Mills
Charles C. Morris,
Town of Linden



Thomas J. Lloyd,
Director

Cecil P. Combs,
Deputy Director

Walter Clark,
Roy Turner,
Sara E. Piland,
Cumberland County

Benny Pearce,
Town of Eastover

COUNTY of CUMBERLAND

Planning & Inspections Department

FINDINGS OF FACT AND ORDER

December 17, 2008

CASE #: MH 5703-2008

TO: Alberta C. Baker Heirs
C/O James Robert Baker & Parties of Interest
PO Box 151
Hope Mills, NC 28348-0151

Property at: 1828 Smith Road, Hope Mills, NC

A Complaint, Notice of Hearing and Report of Inspection were legally served to the owner or owner's agent, and any party of interest. These documents were in fact received by the owner or owner's agent and party of interest on 12/4/2008.

Pursuant of law, a Hearing was conducted in Room 101, of the old courthouse at 130 Gillespie Street, Fayetteville, NC on 12/11/2008 at 9:45:00 AM. The items identified below took place at the Hearing:

- 1. No owner or party of interest, or their agent, or representative appeared.
- 2. An answer was filed by owners and/or parties of interest. The answer was heard, read, and considered. Those answering by phone was: Russell Baker.
- 3. The undersigned inspector personally inspected the dwelling described in the Complaint and Notice of Hearing dated, 11/18/2008. Upon the record and all of the evidence offered and contentions made, the undersigned Hearing Officer does thereby find the following fact:
 - a. The dwelling in question is violative of the Cumberland County Housing Ordinance as per findings in the inspection report with an assigned case number of MH 5703-2008, dated 11/14/2008.
 - b. Due to these findings, the dwelling are found to be in a substandard condition in accordance with the Cumberland County Ordinance.
 - c. The dwelling is unfit for human habitation.

4. Due to facts presented above, the Hearing Officer orders as follows:
- a. The owners and/or parties of interest of the dwelling named above are required to bring such dwelling into compliance with the Cumberland County Housing Ordinance by either repairing, altering, and improving the dwelling up to a minimum standard or by demolishing the structure and then causing the debris to be removed from the premises by a date not later than **2/11/2008**. **All required permits must be obtained. A copy of this order must be presented when obtaining permits.**
 - b. The dwelling shall remain vacated until compliance with this order is completed and removed by the inspector, and the lot must be continuously maintained.
 - c. The structure shall be/remain secured.
 - d. By authority of North Carolina General Statutes 14-4, violation of the County code is punishable as a Class 3 Misdemeanor in criminal court and also subjects the violator to injunctive relief and/or a civil penalty of \$50.00 per day for each day's continuing violation after _____.
 - e. The County Planning/Inspection Department may immediately begin procedures to seek a demolition ordinance from the Cumberland County Board of Commissioners for failure to bring the property into compliance by **2/11/2008**. The cost of said demolition will be assessed against the real property in the form of a lien.

An appeal may be made to the Cumberland County Housing Board of Appeals. If an appeal is requested, it must be made in writing and within the time limits specified in the enclosed appeal procedures.

Ken Sykes
Hearing Officer

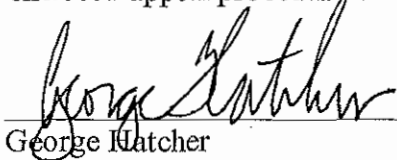

George Katcher
Code Enforcement Officer

Enclosed: Appeals Procedures & Form

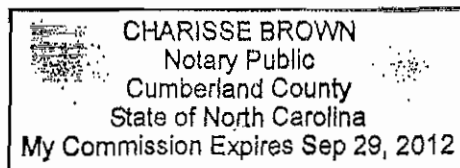
cc: See Distribution List

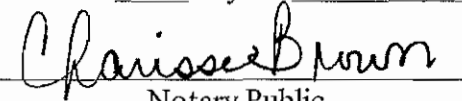

Sworn to and Subscribed to by me
this the 17th day of December, 2008

Notary Public
My Commission Expires: 9/29/2012

PROOF OF SERVICE OF FINDINGS OF FACT AND ORDER
DATED 12/17/08 CASE NUMBER MH 5703-2008

NORTH CAROLINA
COUNTY OF CUMBERLAND

PLANNING/INSPECTIONS DEPARTMENT

RE: ALBERTA C. BAKER HEIRS C/O RUSSELL BAKER
Name of Violator

MH 5703-2008
Case Number

AFFIDAVIT OF RETURN OF SERVICE
(Personal Service to Individual)

I, George Hatcher, Code Enforcement Officer, with the Cumberland County Inspections Department,
(name & title)

personally served ALBERTA C. BAKER HEIRS, C/O RUSSELL BAKER, a copy of the FINDINGS OF FACT AND
(name of violator)

ORDER AND APPEALS PROCEDURES, citing violations of Article IV, CHAPTER 4 of the Cumberland County

Ordinance by mailing said notice(s) via 1st class mail and certified mail to: SEE DISTRIBUTION LIST

and by posting at: 1828 SMITH ROAD, HOPE MILLS, NC 28348.

I further certify that said service was completed on this the 23rd day of DECEMBER 2008
20_____.



George Hatcher
Code Enforcement Officer

Sworn to and subscribed to before me

this the 23rd day of Dec, 2009.

Charisse Brown
Notary Public

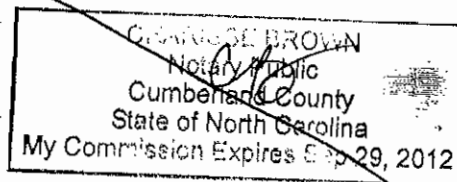
My Commission Expires: 9-29-12



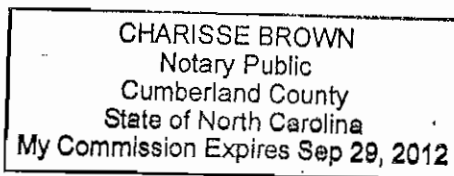

EXHIBIT A

**DISTRIBUTION LIST FOR
COMPLAINT AND NOTICE OF HEARING
BEFORE THE HOUSING INSPECTOR
CASE # MH-5703-2008**

Russell Baker & Parties Of Interest
PO Box 151
Hope Mills, NC 28348-0151

Lee Rogers Baker & Parties Of Interest
62 Virginia Avenue
Apt 1
Jersey City, NJ 07304-2220

Lula Bilbry & Parties Of Interest
1334 Verlie Drive #2418
Spring Lake, NC 28390

Delecta Baker Byrd & Parties Of Interest
1000 Oak Tree Drive
Apt J6
North Brunswick, NJ 08902-1735

EXHIBIT "A"

AFFIDAVIT OF THE HOUSING INSPECTOR'S REPORT
BEFORE THE BOARD OF CUMBERLAND COUNTY COMMISSIONERS

I, George Hatcher, Inspector for the County of Cumberland Inspection Department, acting in my official capacity, being duly sworn, depose and say:

BACKGROUND: That the following is a report on Minimum Housing case number MH 5530-2008.

Property Owner: Diane Crisp Godwin

Property Address: 3943 Camden Road (lot to right of 3939 Camden Road), Fayetteville, NC

Tax Parcel Identification Number: 0425-14-5774

SYNOPSIS: This property was inspected on 5/27/2008. The property owners and parties of interest were legally served with Notice of Violations and was afforded a Hearing on 6/25/2008. No one attended the Hearing. It was ordered that the structure be repaired to a minimum standard for human habitation, or be demolished and the debris removed from the premises by a date not later than 8/25/2008. The property owners and parties of interest were notified of the appeal procedures when they were served with the Findings of Fact and Order. (See Exhibit A for Findings of Fact and Order.) No appeal was filed. Upon my visit to the property on 4/9/2009 no corrective action had been made to the structure. The structure is presently vacant and unsecured. In its present state, the structure constitutes a fire, health, and safety hazard.

The estimated cost to repair the structure to a minimum standard for human habitation is \$15,000.00. The Assessor for Cumberland County has the structure presently valued at \$500.00 (for salvageable materials).

Attached is a map depicting the location of the property. (See Exhibit B.)

RECOMMENDATION: IT IS THE RECOMMENDATION OF THE PLANNING & INSPECTION DEPARTMENT THAT THE STRUCTURE BE DEMOLISHED, AND THE DEBRIS REMOVED FROM THE LOT.

George Hatcher
Affiant
Code Enforcement Officer
County of Cumberland

Sworn to and Subscribed to by me this
the 8th day of April 2009.

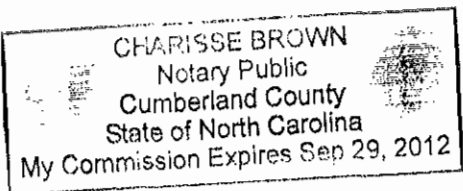

Charisse Brown
Notary Public
My Commission Expires: 9/29/12

**BOARD FINDINGS AND ACTION CHECK LIST
MINIMUM HOUSING REHABILITATION AND/OR DEMOLITION ORDINANCE**

Name(s) of Owner(s)

Appearances:

Inspection Dept. Case No.:

BOARD OF COUNTY COMMISSIONERS MOTION:

1. If the Board feels that the structure should be demolished, the Board's motion should be:

To adopt the order and report of the Minimum Housing Inspector as the true facts in this case, and

To order the property owner to remove or demolish the dwelling within _____ days.

To order the Inspector to remove or demolish the dwelling, if the owner fails to do so and impose a lien on the real property for the cost of such action.

To direct the clerk to incorporate the foregoing findings and orders in an ordinance certified by the Chairman and record the same in the Register of Deeds.

2. **If the Board feels that the property can be rehabilitated, the Board's motion should be:**

To adopt the order and report of the Minimum Housing Inspector as the true facts in this case.

To order the property owner to rehabilitate the property within _____ days.

To order the property owner to vacate and secure the property within _____ days pending rehabilitation.

To order the Inspector to rehabilitate the property or remove or demolish the dwelling, if the owner fails to do so and impose a lien on the real property for the cost of such action.

To direct the clerk to incorporate the foregoing findings and orders in an ordinance certified by the Chairman and record the same in the Register of Deeds.

3. **If the Board wishes to delay action on the case, the Board's motion should be:**

To adopt the order and report of the Minimum Housing Inspector as the true facts in this case.

To delay a decision on the case until _____ (date) in order to give the owner or party of interest time to: _____

4. In addition there is imposed a civil penalty in the amount of \$ _____ per day (up to a maximum amount of \$3,000.00) for failure to comply with the terms of this Ordinance.

Donovan McLaurin,
Chair
Wade, Falcon & Godwin

Lori Epler,
Vice-Chair
Cumberland County

Garland C. Hostetter,
Town of Spring Lake
Harvey Cain, Jr.,
Town of Stedman
Patricia Hall,
Town of Hope Mills
Charles C. Morris,
Town of Linden

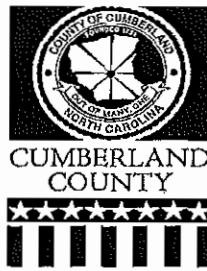

COUNTY of CUMBERLAND

Planning and Inspections Department

Thomas J. Lloyd,
Director

Cecil P. Combs,
Deputy Director

Clifton McNeill, Jr.,
Roy Turner,
Sara E. Piland,
Cumberland County

FINDINGS OF FACT AND ORDER

June 25, 2008

CASE #: MH 5530-2008

TO: Diane Crisp Godwin & Parties of Interest
156 Snowhill Road
St Pauls, NC 28384

Property at: lot to right of 3939 Camden Road

A Complaint, Notice of Hearing and Report of Inspection were legally served to the owner or owner's agent, and any party of interest. These documents were in fact received by the owner or owner's agent and party of interest on 6/3/2008.

Pursuant of law, a Hearing was conducted in Room 101, of the old courthouse at 130 Gillespie Street, Fayetteville, NC on 6/25/2008 at 9:45:00 AM. The items identified below took place at the Hearing:

- 1. No owner or party of interest, or their agent, or representative appeared.
- 2. An answer was filed by owners and/or parties of interest. The answer was heard, read, and considered. Those present were:
- 3. The undersigned inspector personally inspected the dwelling described in the Complaint and Notice of Hearing dated, 05/27/2008. Upon the record and all of the evidence offered and contentions made, the undersigned Hearing Officer does thereby find the following fact:
 - a. The dwelling in question is violative of the Cumberland County Housing Ordinance as per findings in the inspection report with an assigned case number of MH 5530-2008, dated 5/27/2008.
 - b. Due to these findings, the dwelling are found to be in a substandard condition in accordance with the Cumberland County Ordinance.
 - c. The dwelling is unfit for human habitation.

Findings and Facts of Order

Case #: MH 5530-2008

Page 2

4. Due to facts presented above, the Hearing Officer orders as follows:
- a. The owners and/or parties of interest of the dwelling named above are required to bring such dwelling into compliance with the Cumberland County Housing Ordinance by either repairing, altering, and improving the dwelling up to a minimum standard or by demolishing the structure and then causing the debris to be removed from the premises by a date not later than **8/25/2008**. **All required permits must be obtained. A copy of this order must be presented when obtaining permits.**
 - b. The dwelling shall remain vacated until compliance with this order is completed and removed by the inspector, and the lot must be continuously maintained.
 - c. The structure shall be/remain secured.
 - d. By authority of North Carolina General Statutes 14-4, violation of the County code is punishable as a Class 3 Misdemeanor in criminal court and also subjects the violator to injunctive relief and/or a civil penalty of \$50.00 per day for each day's continuing violation after _____.
 - e. The County Planning/Inspection Department may immediately begin procedures to seek a demolition ordinance from the Cumberland County Board of Commissioners for failure to bring the property into compliance by **8/25/2008**. The cost of said demolition will be assessed against the real property in the form of a lien.

An appeal may be made to the Cumberland County Housing Board of Appeals. If an appeal is requested, it must be made in writing and within the time limits specified in the enclosed appeal procedures.

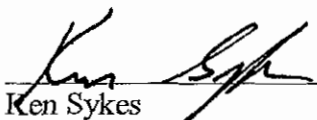

Ken Sykes
Hearing Officer

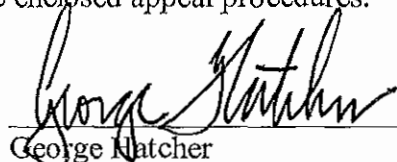

George Hatcher
Code Enforcement Officer

Enclosed: Appeals Procedures & Form

cc:

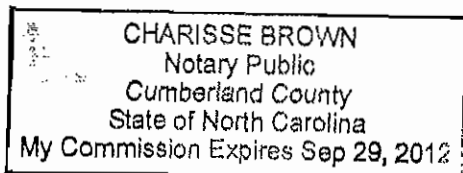

Sworn to and Subscribed to by me
this the 25th day of June, 2008

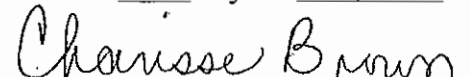

Notary Public
My Commission Expires: 9/29/2012

**PROOF OF SERVICE OF FINDINGS OF FACT AND ORDER
DATED 6/25/08 CASE NUMBER MH 5530-2008**

SENDER: COMPLETE THIS SECTION	COMPLETE THIS SECTION ON DELIVERY
<ul style="list-style-type: none"> ■ Complete items 1, 2, and 3. Also complete item 4 if Restricted Delivery is desired. ■ Print your name and address on the reverse so that we can return the card to you. ■ Attach this card to the back of the mailpiece, or on the front if space permits. 	<p>A. Signature <input checked="" type="checkbox"/> Addressee <input type="checkbox"/> Agent</p> <p>B. Received by (<i>Printed Name</i>)</p> <p>C. Date of Delivery <i>6-27-08</i></p> <p>D. Is delivery address different from item 1? <input type="checkbox"/> Yes If YES, enter delivery address below: <input type="checkbox"/> No</p>
<p>1. Article Addressed to:</p> <p align="right">FOFO MH5530GH</p> <p>DIANE CRISP GODWIN & PARTIES OF INTEREST 156 SNOWHILL ROAD ST PAULS NC 28384</p>	<p>3. Service Type</p> <p><input type="checkbox"/> Certified Mail <input type="checkbox"/> Express Mail</p> <p><input type="checkbox"/> Registered <input type="checkbox"/> Return Receipt for Merchandise</p> <p><input type="checkbox"/> Insured Mail <input type="checkbox"/> C.O.D.</p>
<p>2. Article Number: (Transfer from service label)</p>	<p>4. Restricted Delivery? (Extra Fee) <input type="checkbox"/> Yes</p> <p align="center">7003 2260 0000 4728 7914</p>

PS Form 3811, February 2004

Domestic Return Receipt

102595-02-M-1540

MAP DEPICTING LOCATION OF PROPERTY
Property Owner: Diane C. Godwin
3943 Camden Road, Fayetteville, NC
MINIMUM HOUSING CASE # MH 5530-2008
TAX PARCEL IDENTIFICATION NUMBER: 0425-14-5774

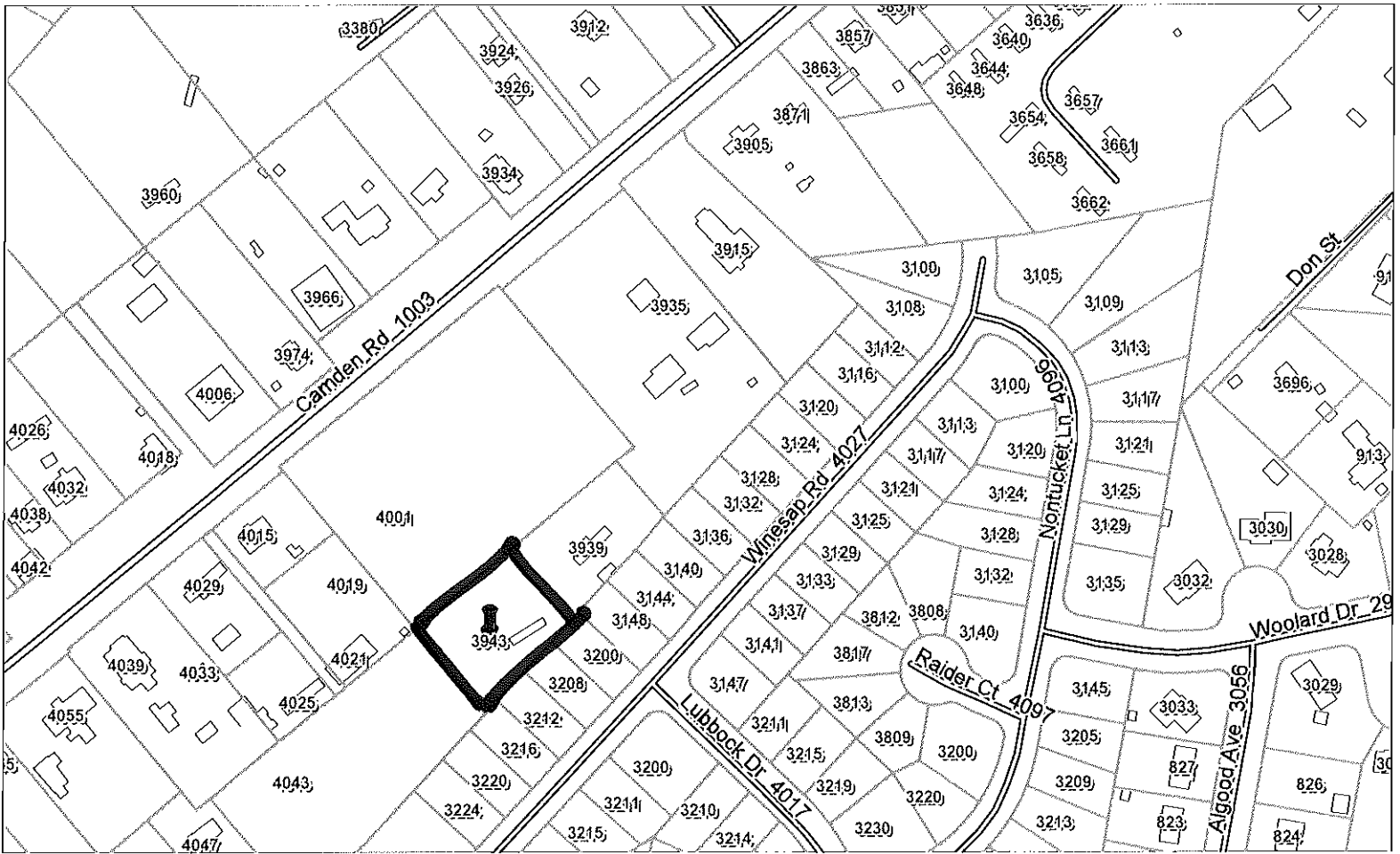

**AFFIDAVIT OF THE HOUSING INSPECTOR'S REPORT
BEFORE THE BOARD OF CUMBERLAND COUNTY COMMISSIONERS**

I, George Hatcher, Code Enforcement Officer for the County of Cumberland Planning & Inspection Department, acting in my official capacity, being duly sworn, depose and say:

BACKGROUND: That the following is a report on Minimum Housing Case Number MH5512-2008

Property Owner: N.J. Thaggard Heirs, c/o Elvoir Fisher

Property Address: 7011 Huffman Drive, Fayetteville, NC

Tax Parcel Identification Number: 0460-10-1862

SYNOPSIS: This property was inspected on April 29, 2008. All property owners and parties of interest were legally served the Notice of Violations and afforded a Hearing on May 28, 2008. Elvoir & Frank Fisher **attended** the Hearing. It was ordered that the structure be repaired to a minimum standard for human habitation, or be demolished and the debris removed from the premises no later than August 28, 2008. The property owners and parties of interest were notified of the appeal procedures when they were served with the Findings of Fact and Order. (See Exhibit A for the Findings of Fact and Order.) No Appeal was filed. Upon my visit to the property on April 9, 2009, no corrective action has been made to the structure. The structure is presently vacant and unsecured. In it's present state, this structure constitutes a fire, health, and safety hazard. The estimated cost to repair the structure to a minimum standard for human habitation is \$20,000.00. The Assessor for Cumberland County has this structure presently valued at \$500.00. Attached is a map depicting the location of the property. (See Exhibit B.)

RECOMMENDATION: IT IS THE RECOMMENDATION OF THE PLANNING & INSPECTION DEPARTMENT THAT THIS STRUCTURE BE DEMOLISHED, AND THE DEBRIS REMOVED FROM THE LOT.

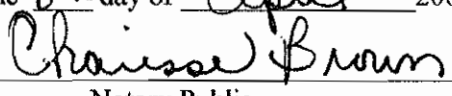

George Hatcher, Affiant
Code Enforcement Officer/County of Cumberland

Sworn to and Subscribed to by me this
the 8th day of April 2009.

Notary Public

CHARISSE BROWN
Notary Public
Cumberland County
State of North Carolina
My Commission Expires Sep 29, 2012

My Commission Expires: 09/29/2012.

**BOARD FINDINGS AND ACTION CHECK LIST
MINIMUM HOUSING REHABILITATION AND/OR DEMOLITION ORDINANCE**

Name(s) of Owner(s)

Appearances:

Inspection Dept. Case No.:

BOARD OF COUNTY COMMISSIONERS MOTION:

1. If the Board feels that the structure should be demolished, the Board's motion should be:

To adopt the order and report of the Minimum Housing Inspector as the true facts in this case, and

To order the property owner to remove or demolish the dwelling within _____ days.

To order the Inspector to remove or demolish the dwelling, if the owner fails to do so and impose a lien on the real property for the cost of such action.

To direct the clerk to incorporate the foregoing findings and orders in an ordinance certified by the Chairman and record the same in the Register of Deeds.

2. **If the Board feels that the property can be rehabilitated, the Board's motion should be:**

To adopt the order and report of the Minimum Housing Inspector as the true facts in this case.

To order the property owner to rehabilitate the property within _____ days.

To order the property owner to vacate and secure the property within _____ days pending rehabilitation.

To order the Inspector to rehabilitate the property or remove or demolish the dwelling, if the owner fails to do so and impose a lien on the real property for the cost of such action.

To direct the clerk to incorporate the foregoing findings and orders in an ordinance certified by the Chairman and record the same in the Register of Deeds.

3. **If the Board wishes to delay action on the case, the Board's motion should be:**

To adopt the order and report of the Minimum Housing Inspector as the true facts in this case.

To delay a decision on the case until _____ (date) in order to give the owner or party of interest time to: _____

4. In addition there is imposed a civil penalty in the amount of \$ _____ per day (up to a maximum amount of \$3,000.00) for failure to comply with the terms of this Ordinance.

Donovan McLaurin,
Chair
Wade, Falcon & Godwin

Lori Epler,
Vice-Chair
Cumberland County

Garland C. Hostetter,
Town of Spring Lake
Harvey Cain, Jr.,
Town of Stedman
Patricia Hall,
Town of Hope Mills
Charles C. Morris,
Town of Linden



COUNTY of CUMBERLAND

Planning and Inspections Department

Thomas J. Lloyd,
Director

Cecil P. Combs,
Deputy Director

Clifton McNeill, Jr.,
Roy Turner,
Sara E. Piland,
Cumberland County

FINDINGS OF FACT AND ORDER

May 29, 2008

CASE #: MH 5512-2008

TO: N. J. Thaggard Heirs
C/O Elvoir Fisher & Parties of Interest
5886 Matt Simmons Road
Fayetteville, NC 28301

Property at: 7011 Huffman Drive, Fayetteville, NC

A Complaint, Notice of Hearing and Report of Inspection were legally served to the owner or owner's agent, and any party of interest. These documents were in fact received by the owner or owner's agent and party of interest on 5/6/2008.

Pursuant of law, a Hearing was conducted in Room 101, of the old courthouse at 130 Gillespie Street, Fayetteville, NC on 5/28/2008 at 9:30:00 AM. The items identified below took place at the Hearing:

- 1. No owner or party of interest, or their agent, or representative appeared.
- 2. An answer was filed by owners and/or parties of interest. The answer was heard, read, and considered. Those present were: Elvoir & Frank Fisher.
- 3. The undersigned inspector personally inspected the dwelling described in the Complaint and Notice of Hearing dated, 5/5/2008. Upon the record and all of the evidence offered and contentions made, the undersigned Hearing Officer does thereby find the following fact:
 - a. The dwelling in question is violative of the Cumberland County Housing Ordinance as per findings in the inspection report with an assigned case number of MH 5512-2008, dated 4/29/2008.
 - b. Due to these findings, the dwelling are found to be in a substandard condition in accordance with the Cumberland County Ordinance.
 - c. The dwelling is unfit for human habitation.

- 4. Due to facts presented above, the Hearing Officer orders as follows:
 - a. The owners and/or parties of interest of the dwelling named above are required to bring such dwelling into compliance with the Cumberland County Housing Ordinance by either repairing, altering, and improving the dwelling up to a minimum standard or by demolishing the structure and then causing the debris to be removed from the premises by a date not later than **8/28/2008**. **All required permits must be obtained. A copy of this order must be presented when obtaining permits.**
 - b. The dwelling shall remain vacated until compliance with this order is completed and removed by the inspector, and the lot must be continuously maintained.
 - c. The structure shall be/remain secured.
 - d. By authority of North Carolina General Statutes 14-4, violation of the County code is punishable as a Class 3 Misdemeanor in criminal court and also subjects the violator to injunctive relief and/or a civil penalty of \$50.00 per day for each day's continuing violation after _____.
 - e. The County Planning/Inspection Department may immediately begin procedures to seek a demolition ordinance from the Cumberland County Board of Commissioners for failure to bring the property into compliance by **8/28/2008**. The cost of said demolition will be assessed against the real property in the form of a lien.

An appeal may be made to the Cumberland County Housing Board of Appeals. If an appeal is requested, it must be made in writing and within the time limits specified in the enclosed appeal procedures.

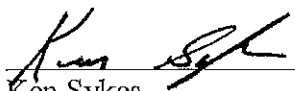

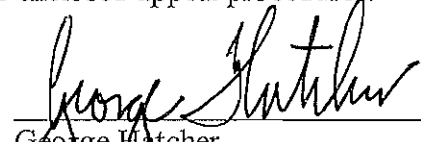
 Ken Sykes
 Hearing Officer

 George Hatcher
 Code Enforcement Officer

Enclosed: Appeals Procedures & Form

cc:

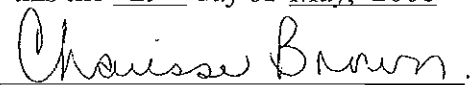
CHARISSE BROWN Notary Public Cumberland County State of North Carolina My Commission Expires Sep 29, 2012

Sworn to and Subscribed to by me
 this the 29th day of May, 2008

 Notary Public
 My Commission Expires: 9/29/2012

**PROOF OF SERVICE OF FINDINGS OF FACT AND ORDER
DATED 5/29/08 CASE NUMBER MH 5512-2008**

SENDER: COMPLETE THIS SECTION	COMPLETE THIS SECTION ON DELIVERY
<ul style="list-style-type: none"> ■ Complete items 1, 2, and 3. Also complete item 4 if Restricted Delivery is desired. ■ Print your name and address on the reverse so that we can return the card to you. ■ Attach this card to the back of the mailpiece, or on the front if space permits. 	<p>A. Signature <input checked="" type="checkbox"/> Agent <input type="checkbox"/> Addressee</p> <p><i>[Handwritten Signature]</i></p>
<p>1. Article Addressed to:</p> <div style="border: 1px solid black; padding: 5px; margin: 10px 0;"> <p align="right">FOFO MH5512GH</p> <p>N J THAGGARD HEIRS C/O ELVOIR FISHER & PARTIES OF INTEREST 5886 MATT SIMMONS ROAD FAYETTEVILLE NC 28301</p> </div>	<p>B. Received by (Printed Name) C. Date of Delivery</p> <p><i>[Handwritten Name]</i> <i>6-2-08</i></p> <p>D. Is delivery address different from item 1? <input type="checkbox"/> Yes If YES, enter delivery address below: <input type="checkbox"/> No</p>
<p>2. Article Number (Transfer from service label)</p>	<p>3. Service Type</p> <p><input type="checkbox"/> Certified Mail <input type="checkbox"/> Express Mail</p> <p><input type="checkbox"/> Registered <input type="checkbox"/> Return Receipt for Merchandise</p> <p><input type="checkbox"/> Insured Mail <input type="checkbox"/> C.O.D.</p> <p>4. Restricted Delivery? (Extra Fee) <input type="checkbox"/> Yes</p>
<p>7007 0710 0000 4526 3516</p>	

PS Form 3811, February 2004

Domestic Return Receipt

102595-02-M-1540

MAP DEPICTING LOCATION OF PROPERTY
Property Owner: NJ Thaggard
7011 Huffman Dr, Fayetteville, NC
MINIMUM HOUSING CASE # MH 5512-2008
TAX PARCEL IDENTIFICATION NUMBER: 0460-10-1862

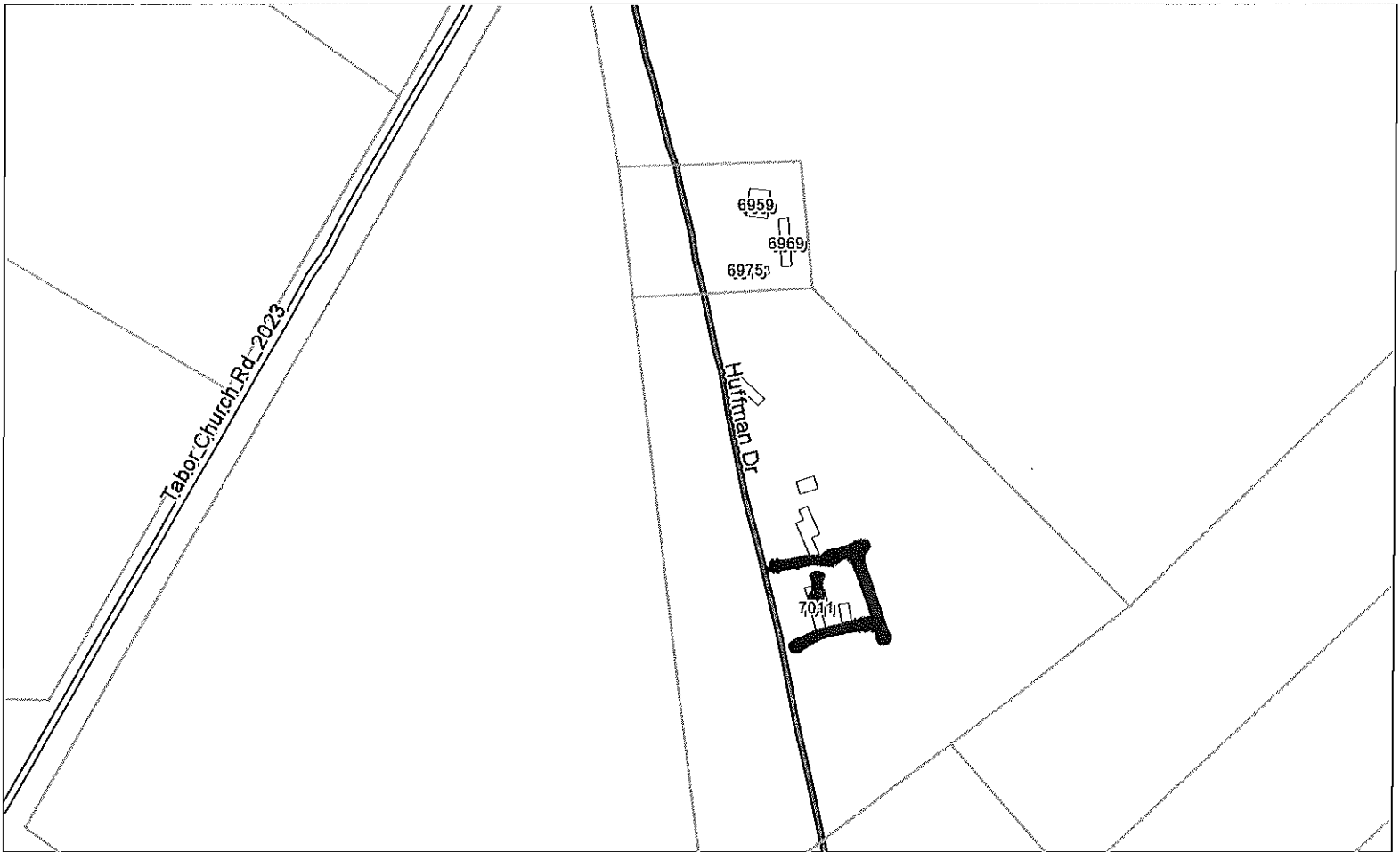

EXHIBIT B

AFFIDAVIT OF THE HOUSING INSPECTOR'S REPORT
BEFORE THE BOARD OF CUMBERLAND COUNTY COMMISSIONERS

I, George Hatcher, Inspector for the County of Cumberland Inspection Department, acting in my official capacity, being duly sworn, depose and say:

BACKGROUND: That the following is a report on Minimum Housing case number MH 5729-2008.

Property Owner: Stephanie L. Baker

Property Address: 5905 St. Michaels Dr, Fayetteville, NC

Tax Parcel Identification Number: 0454-51-5679

SYNOPSIS: This property was inspected on 12/17/2008. The property owners and parties of interest were legally served with Notice of Violations and was afforded a Hearing on 1/15/2009. No one attended the Hearing. It was ordered that the structure be repaired to a minimum standard for human habitation, or be demolished and the debris removed from the premises by a date not later than 2/15/2009. The property owners and parties of interest were notified of the appeal procedures when they were served with the Findings of Fact and Order. (See Exhibit A for Findings of Fact and Order.) No appeal was filed. Upon my visit to the property on 4/9/2009 no corrective action had been made to the structure. The structure is presently vacant and reasonably secured. In its present state, the structure constitutes a fire, health, and safety hazard.

The estimated cost to repair the structure to a minimum standard for human habitation is \$15,000.00. The Assessor for Cumberland County has the structure presently valued at \$3,580.00.

Attached is a map depicting the location of the property. (See Exhibit B.)

RECOMMENDATION: IT IS THE RECOMMENDATION OF THE PLANNING & INSPECTION DEPARTMENT THAT THE STRUCTURE BE DEMOLISHED, AND THE DEBRIS REMOVED FROM THE LOT.

George Hatcher
Affiant
Code Enforcement Officer
County of Cumberland

CHARISSE BROWN
Notary Public
Cumberland County
State of North Carolina
My Commission Expires Sep 29, 2012

Sworn to and Subscribed to by me this
the 9th day of April 2009.

Charisse Brown
Notary Public
My Commission Expires: 9/29/12

BOARD FINDINGS AND ACTION CHECK LIST
MINIMUM HOUSING REHABILITATION AND/OR DEMOLITION ORDINANCE

Name(s) of Owner(s)

Appearances:

Inspection Dept. Case No.:

BOARD OF COUNTY COMMISSIONERS MOTION:

1. If the Board feels that the structure should be demolished, the Board's motion should be:

To adopt the order and report of the Minimum Housing Inspector as the true facts in this case, and

To order the property owner to remove or demolish the dwelling within _____ days.

To order the Inspector to remove or demolish the dwelling, if the owner fails to do so and impose a lien on the real property for the cost of such action.

To direct the clerk to incorporate the foregoing findings and orders in an ordinance certified by the Chairman and record the same in the Register of Deeds.

2. **If the Board feels that the property can be rehabilitated, the Board's motion should be:**

To adopt the order and report of the Minimum Housing Inspector as the true facts in this case.

To order the property owner to rehabilitate the property within _____ days.

To order the property owner to vacate and secure the property within _____ days pending rehabilitation.

To order the Inspector to rehabilitate the property or remove or demolish the dwelling, if the owner fails to do so and impose a lien on the real property for the cost of such action.

To direct the clerk to incorporate the foregoing findings and orders in an ordinance certified by the Chairman and record the same in the Register of Deeds.

3. **If the Board wishes to delay action on the case, the Board's motion should be:**

To adopt the order and report of the Minimum Housing Inspector as the true facts in this case.

To delay a decision on the case until _____ (date) in order to give the owner or party of interest time to: _____

4. In addition there is imposed a civil penalty in the amount of \$ _____ per day (up to a maximum amount of \$3,000.00) for failure to comply with the terms of this Ordinance.

Donovan McLaurin,
Chair
Wade, Falcon & Godwin

Lori Epler,
Vice-Chair
Cumberland County

Garland C. Hostetter,
Town of Spring Lake
Harvey Cain, Jr.,
Town of Stedman
Patricia Hall,
Town of Hope Mills
Charles C. Morris,
Town of Linden



COUNTY of CUMBERLAND

Planning & Inspections Department

Thomas J. Lloyd,
Director

Cecil P. Combs,
Deputy Director

Walter Clark,
Roy Turner,
Sara E. Piland,
Cumberland County

Benny Pearce,
Town of Eastover

FINDINGS OF FACT AND ORDER

January 16, 2009

CASE #: MH 5729-2008

TO: Stephanie L. Baker & Parties of Interest
120 Everitte Road
Parkton, NC 28371

Property at: 5905 St. Michaels Dr, Fayetteville, NC

A Complaint, Notice of Hearing and Report of Inspection were legally served to the owner or owner's agent, and any party of interest. These documents were in fact received by the owner or owner's agent and party of interest on 12/22/2008.

Pursuant of law, a Hearing was conducted in Room 101, of the old courthouse at 130 Gillespie Street, Fayetteville, NC on 1/15/2009 at 9:30:00 AM. The items identified below took place at the Hearing:

- 1. No owner or party of interest, or their agent, or representative appeared.
- 2. An answer was filed by owners and/or parties of interest. The answer was heard, read, and considered. Those present were: George Hatcher & Ken Sykes.
- 3. The undersigned inspector personally inspected the dwelling described in the Complaint and Notice of Hearing dated, 12/19/2008. Upon the record and all of the evidence offered and contentions made, the undersigned Hearing Officer does thereby find the following fact:
 - a. The dwelling in question is violative of the Cumberland County Housing Ordinance as per findings in the inspection report with an assigned case number of MH 5729-2008, dated 12/17/2008.
 - b. Due to these findings, the dwelling are found to be in a substandard condition in accordance with the Cumberland County Ordinance.
 - c. The dwelling is unfit for human habitation.

- 4. Due to facts presented above, the Hearing Officer orders as follows:
 - a. The owners and/or parties of interest of the dwelling named above are required to bring such dwelling into compliance with the Cumberland County Housing Ordinance by either repairing, altering, and improving the dwelling up to a minimum standard or by demolishing the structure and then causing the debris to be removed from the premises by a date not later than 2/15/2009. **All required permits must be obtained. A copy of this order must be presented when obtaining permits.**
 - b. The dwelling shall remain vacated until compliance with this order is completed and removed by the inspector, and the lot must be continuously maintained.
 - c. The structure shall be/remain secured.
 - d. By authority of North Carolina General Statutes 14-4, violation of the County code is punishable as a Class 3 Misdemeanor in criminal court and also subjects the violator to injunctive relief and/or a civil penalty of \$50.00 per day for each day's continuing violation after ____.
 - e. The County Planning/Inspection Department may immediately begin procedures to seek a demolition ordinance from the Cumberland County Board of Commissioners for failure to bring the property into compliance by 2/15/2009. The cost of said demolition will be assessed against the real property in the form of a lien.

An appeal may be made to the Cumberland County Housing Board of Appeals. If an appeal is requested, it must be made in writing and within the time limits specified in the enclosed appeal procedures.

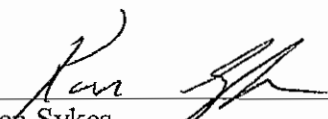

 Ken Sykes
 Hearing Officer

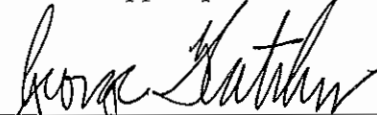

 George Hatcher
 Code Enforcement Officer

Enclosed: Appeals Procedures & Form

cc:

CHARISSE BROWN
 Notary Public
 Cumberland County
 State of North Carolina
 My Commission Expires Sep 29, 2012

Sworn to and Subscribed to by me
this the 10th day of January, 2009

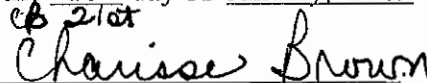

 Charisse Brown
 Notary Public
 My Commission Expires: 9/29/2012

PROOF OF SERVICE OF FINDINGS OF FACT AND ORDER

DATED 1/16/09 CASE NUMBER MH 5729-2008

NORTH CAROLINA

PLANNING/INSPECTIONS DEPARTMENT

COUNTY OF CUMBERLAND

RE: STEPHANIE L. BAKER
Name of Violator

MH 5729-2008
Case Number

AFFIDAVIT OF RETURN OF SERVICE
(Personal Service to Individual)

I, George Hatcher, Code Enforcement Officer, with the Cumberland County Inspections Department,
(name & title)

personally served Stephanie L. Baker, a copy of the Findings of Fact and Order, citing violations of
(name of violator)

Article IV, CHAPTER 4 of the Cumberland County Ordinance by mailing said notice(s) via 1st class

mail and certified mail to the following address: 120 Everitte Road, Parkton, NC 28371 and by posting at:

5905 St. Michaels Drive, Fayetteville, NC.

I further certify that said service was completed on this the 27th day of JANUARY,
20 09.

George Hatcher
George Hatcher
Code Enforcement Officer

Sworn to and subscribed to before me

this the 27th day of Jan, 20 09.

Charisse Brown
Notary Public

My Commission Expires: 9-29-12

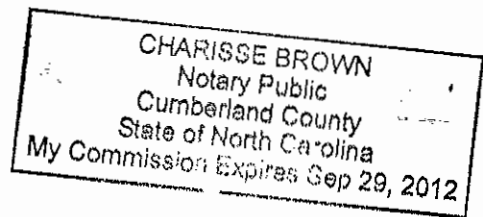

MAP DEPICTING LOCATION OF PROPERTY
Property Owner: Stephanie Baker
5905 St Michaels Dr, Fayetteville, NC
MINIMUM HOUSING CASE # MH 5729-2008
TAX PARCEL IDENTIFICATION NUMBER: 0454-51-5679

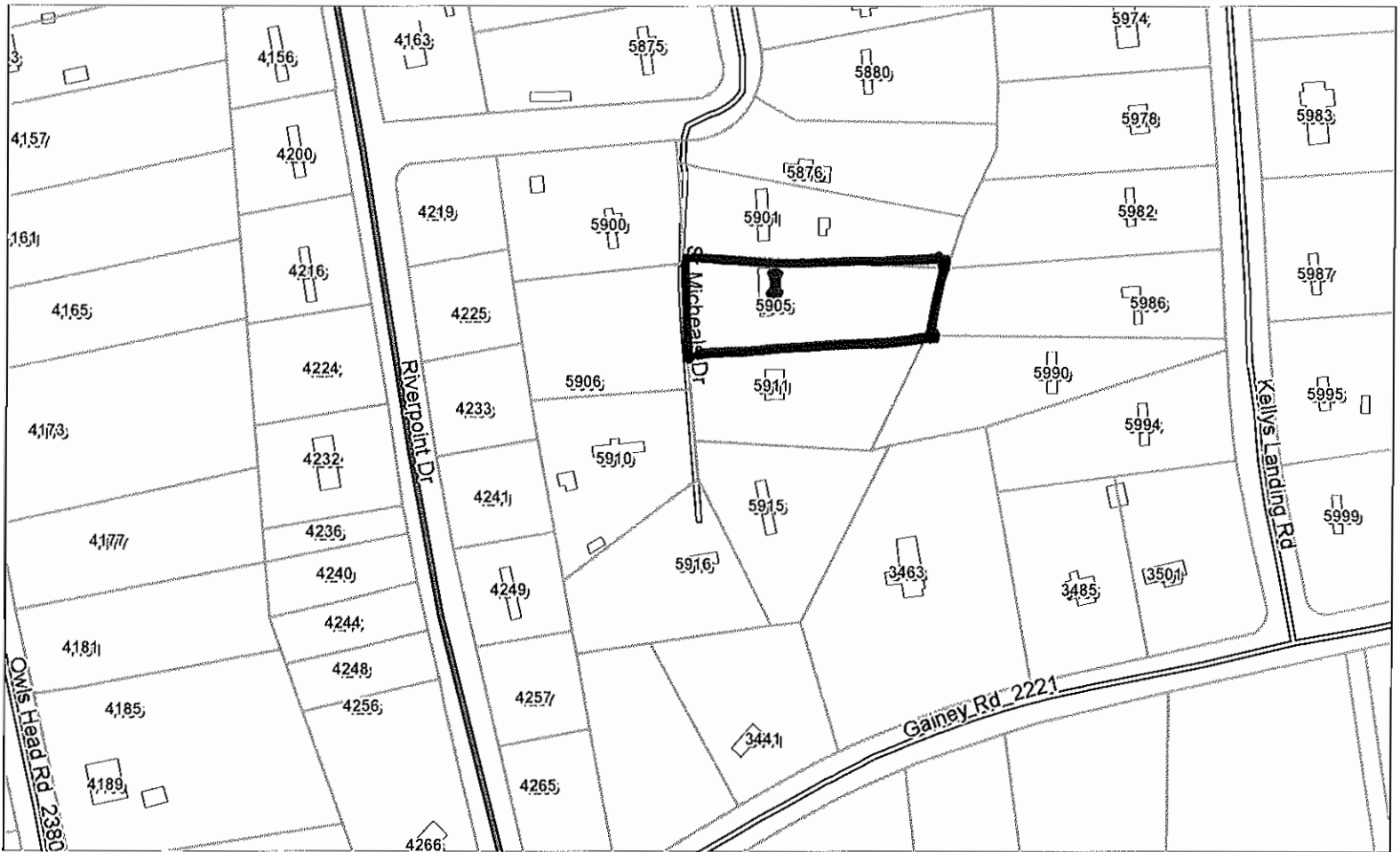

EXHIBIT B

**AFFIDAVIT OF THE HOUSING INSPECTOR'S REPORT
BEFORE THE BOARD OF CUMBERLAND COUNTY COMMISSIONERS**

I, George Hatcher, Code Enforcement Officer for the County of Cumberland Planning & Inspection Department, acting in my official capacity, being duly sworn, depose and say:

BACKGROUND: That the following is a report on Minimum Housing Case Number MH5716 & MH5717-2008

Property Owner: Betty R. Smith, c/o Charles Allen Smith

Property Address: 1395, 1399, 1403 and 1407 Tom Starling Road, Fayetteville, NC

Tax Parcel Identification Number: **0433-85-2853 and 0433-85-4831**

SYNOPSIS: This property (consisting of one singlewide manufactured home and four structures) was inspected on December 10, 2008. All property owners and parties of interest were legally served the Notice of Violations and afforded a Hearing on January 8, 2009. Charles A. Smith **attended** the Hearing. It was ordered that the structures be repaired to a minimum standard for human habitation, or be demolished and the debris removed from the premises no later than February 9, 2009. The property owners and parties of interest were notified of the appeal procedures when they were served with the Findings of Fact and Order. (See Exhibit A for the Findings of Fact and Order.) No Appeal was filed. Upon my visit to the property on April 9, 2009, no corrective action has been made to the structures. The structures are presently vacant and unsecured and being frequented by vagrants. In their present state, these structures constitute a fire, health, and safety hazard. The estimated cost to repair these structures to a minimum standard for human habitation and the Assessor for Cumberland County present value is as follows:

Estimated Cost to Repair Building #1: \$34,000.00	Assessor Value Building #1: \$ 644.00
Building #2: \$15,000.00	Building #2: \$ 490.00
Building #3: \$22,000.00	Building #3: \$ 749.00
Building #4: \$11,000.00	Building #4: \$ 662.00
Mobile Home: \$15,000.00	Mobile Home: \$ 1,500.00

Attached is a map depicting the location of the property (See Exhibit B).

RECOMMENDATION: IT IS THE RECOMMENDATION OF THE PLANNING & INSPECTION DEPARTMENT THAT THESE STRUCTURES BE DEMOLISHED, AND THE DEBRIS REMOVED FROM THE LOT.

George Hatcher
George Hatcher, Affiant
Code Enforcement Officer/County of Cumberland

Sworn to and Subscribed to by me this
the 8 day of April, 2009.
Charisse Brown
Notary Public

CHARISSE BROWN
Notary Public
Cumberland County
State of North Carolina
My Commission Expires Sep 29, 2012

My Commission Expires: 09/20/2012

BOARD FINDINGS AND ACTION CHECK LIST
MINIMUM HOUSING REHABILITATION AND/OR DEMOLITION ORDINANCE

Name(s) of Owner(s)

Appearances:

Inspection Dept. Case No.:

BOARD OF COUNTY COMMISSIONERS MOTION:

1. If the Board feels that the structure should be demolished, the Board's motion should be:

To adopt the order and report of the Minimum Housing Inspector as the true facts in this case,
and

To order the property owner to remove or demolish the dwelling within _____ days.

To order the Inspector to remove or demolish the dwelling, if the owner fails to do so and
impose a lien on the real property for the cost of such action.

To direct the clerk to incorporate the foregoing findings and orders in an ordinance certified by
the Chairman and record the same in the Register of Deeds.

2. **If the Board feels that the property can be rehabilitated, the Board's motion should be:**

To adopt the order and report of the Minimum Housing Inspector as the true facts in this case.

To order the property owner to rehabilitate the property within _____ days.

To order the property owner to vacate and secure the property within _____ days
pending rehabilitation.

To order the Inspector to rehabilitate the property or remove or demolish the dwelling, if the
owner fails to do so and impose a lien on the real property for the cost of such action.

To direct the clerk to incorporate the foregoing findings and orders in an ordinance certified by
the Chairman and record the same in the Register of Deeds.

3. **If the Board wishes to delay action on the case, the Board's motion should be:**

To adopt the order and report of the Minimum Housing Inspector as the true facts in this case.

To delay a decision on the case until _____ (date) in order to give the owner
or party of interest time to: _____

4. In addition there is imposed a civil penalty in the amount of \$ _____ per day (up to
a maximum amount of \$3,000.00) for failure to comply with the terms of this Ordinance.

Donovan McLaurin,
Chair
Wade, Falcon & Godwin

Lori Epler,
Vice-Chair
Cumberland County

Garland C. Hostetter,
Town of Spring Lake
Harvey Cain, Jr.,
Town of Stedman
Patricia Hall,
Town of Hope Mills
Charles C. Morris,
Town of Linden



COUNTY of CUMBERLAND

Planning and Inspections Department

FINDINGS OF FACT AND ORDER

January 8, 2009

CASE #: MH 5717-2008

Thomas J. Lloyd,
Director

Cecil P. Combs,
Deputy Director

Clifton McNeill, Jr.,
Roy Turner,
Sara E. Piland,
Cumberland County

TO: Betty R. Smith
C/O Charles Allen Smith & Parties of Interest
745 Cashmere Court
Sanford, NC 27332

Property at: 1395 Tom Starling Road, Fayetteville, NC

A Complaint, Notice of Hearing and Report of Inspection were legally served to the owner or owner's agent, and any party of interest. These documents were in fact received by the owner or owner's agent and party of interest on 12/30/2008.

Pursuant of law, a Hearing was conducted in Room 101, of the old courthouse at 130 Gillespie Street, Fayetteville, NC on 1/8/2009 at 9:15:00 AM. The items identified below took place at the Hearing:

- 1. No owner or party of interest, or their agent, or representative appeared.
- 2. An answer was filed by owners and/or parties of interest. The answer was heard, read, and considered. Those answering by telephone were: Charles A. Smith
- 3. The undersigned inspector personally inspected the dwelling described in the Complaint and Notice of Hearing dated, 12/11/2008. Upon the record and all of the evidence offered and contentions made, the undersigned Hearing Officer does thereby find the following fact:
 - a. The dwelling in question is violative of the Cumberland County Housing Ordinance as per findings in the inspection report with an assigned case number of MH 5717-2008, dated 12/10/2008.
 - b. Due to these findings, the dwelling are found to be in a substandard condition in accordance with the Cumberland County Ordinance.
 - c. The dwelling is unfit for human habitation.

4. Due to facts presented above, the Hearing Officer orders as follows:
- a. The owners and/or parties of interest of the dwelling named above are required to bring such dwelling into compliance with the Cumberland County Housing Ordinance by either repairing, altering, and improving the dwelling up to a minimum standard or by demolishing the structure and then causing the debris to be removed from the premises by a date not later than 2/9/2009. **All required permits must be obtained. A copy of this order must be presented when obtaining permits.**
 - b. The dwelling shall remain vacated until compliance with this order is completed and removed by the inspector, and the lot must be continuously maintained.
 - c. The structure shall be/remain secured.
 - d. By authority of North Carolina General Statutes 14-4, violation of the County code is punishable as a Class 3 Misdemeanor in criminal court and also subjects the violator to injunctive relief and/or a civil penalty of \$50.00 per day for each day's continuing violation after _____.
 - e. The County Planning/Inspection Department may immediately begin procedures to seek a demolition ordinance from the Cumberland County Board of Commissioners for failure to bring the property into compliance by 2/9/2009. The cost of said demolition will be assessed against the real property in the form of a lien.

An appeal may be made to the Cumberland County Housing Board of Appeals. If an appeal is requested, it must be made in writing and within the time limits specified in the enclosed appeal procedures.



Ken Sykes
Hearing Officer

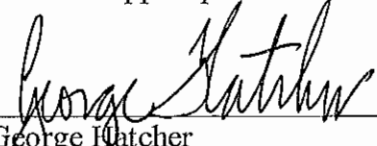

George Hatcher
Code Enforcement Officer

Enclosed: Appeals Procedures & Form

cc:

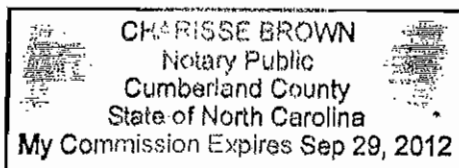

Sworn to and Subscribed to by me
this the 8th day of January, 2009

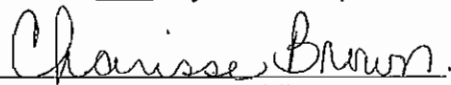

Notary Public
My Commission Expires: 9/29/2012

Donovan McLaurin,
Chair
Wade, Falcon & Godwin

Lori Epler,
Vice-Chair
Cumberland County

Garland C. Hostetter,
Town of Spring Lake
Harvey Cain, Jr.,
Town of Stedman
Patricia Hall,
Town of Hope Mills
Charles C. Morris,
Town of Linden



COUNTY of CUMBERLAND

Planning and Inspections Department

Thomas J. Lloyd,
Director

Cecil P. Combs,
Deputy Director

Clifton McNeill, Jr.,
Roy Turner,
Sara E. Piland,
Cumberland County

FINDINGS OF FACT AND ORDER

January 8, 2009

CASE #: MH 5716-2008

TO: Betty R. Smith
C/O Charles Allen Smith & Parties of Interest
745 Cashmere Court
Sanford, NC 27332

Property at: 1399, 1403, 1407 Tom Starling Road, Fayetteville, NC

A Complaint, Notice of Hearing and Report of Inspection were legally served to the owner or owner's agent, and any party of interest. These documents were in fact received by the owner or owner's agent and party of interest on 12/18/2008.

Pursuant of law, a Hearing was conducted in Room 101, of the old courthouse at 130 Gillespie Street, Fayetteville, NC on 1/8/2009 at 9:15:00 AM. The items identified below took place at the Hearing:

- 1. No owner or party of interest, or their agent, or representative appeared.
- 2. An answer was filed by owners and/or parties of interest. The answer was heard, read, and considered. Those answering by telephone were: Charles A. Smith
- 3. The undersigned inspector personally inspected the dwelling described in the Complaint and Notice of Hearing dated, 12/12/2008. Upon the record and all of the evidence offered and contentions made, the undersigned Hearing Officer does thereby find the following fact:
 - a. The dwelling in question is violative of the Cumberland County Housing Ordinance as per findings in the inspection report with an assigned case number of MH 5716-2008, dated 12/10/2008.
 - b. Due to these findings, the dwelling are found to be in a substandard condition in accordance with the Cumberland County Ordinance.
 - c. The dwelling is unfit for human habitation.

4. Due to facts presented above, the Hearing Officer orders as follows:
- a. The owners and/or parties of interest of the dwelling named above are required to bring such dwelling into compliance with the Cumberland County Housing Ordinance by either repairing, altering, and improving the dwelling up to a minimum standard or by demolishing the structure and then causing the debris to be removed from the premises by a date not later than **2/9/2009**. **All required permits must be obtained. A copy of this order must be presented when obtaining permits.**
 - b. The dwelling shall remain vacated until compliance with this order is completed and removed by the inspector, and the lot must be continuously maintained.
 - c. The structure shall be/remain secured.
 - d. By authority of North Carolina General Statutes 14-4, violation of the County code is punishable as a Class 3 Misdemeanor in criminal court and also subjects the violator to injunctive relief and/or a civil penalty of \$50.00 per day for each day's continuing violation after _____.
 - e. The County Planning/Inspection Department may immediately begin procedures to seek a demolition ordinance from the Cumberland County Board of Commissioners for failure to bring the property into compliance by **2/9/2009**. The cost of said demolition will be assessed against the real property in the form of a lien.

An appeal may be made to the Cumberland County Housing Board of Appeals. If an appeal is requested, it must be made in writing and within the time limits specified in the enclosed appeal procedures.



Ken Sykes
Hearing Officer

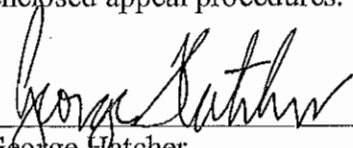

George Hatcher
Code Enforcement Officer

Enclosed: Appeals Procedures & Form

cc:

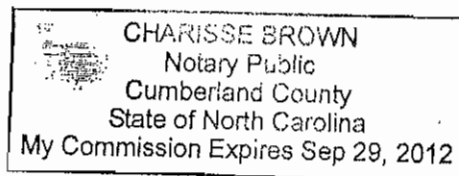

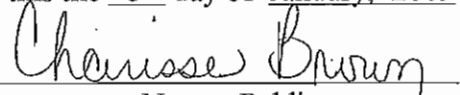
Sworn to and Subscribed to by me
this the 8th day of January, 2009

Notary Public
My Commission Expires: 9/29/2012

**PROOF OF SERVICE OF FINDINGS OF FACT AND ORDER
DATED 1/8/09 CASE NUMBER MH 5716, 5717-2008**



[Home](#) | [Help](#)

[Track & Confirm](#)

Track & Confirm

Search Results

Label/Receipt Number: 9171 0821 3339 3594 6365 51
Status: **Delivered**

Your item was delivered at 3:37 pm on January 10, 2009 in SANFORD, NC 27332. A proof of delivery record may be available through your local Post Office for a fee.

Additional information for this item is stored in files offline.

[Restore Offline Details >](#)



[Return to USPS.com Home >](#)

Track & Confirm

Enter Label/Receipt Number.



[Home](#) | [Help](#)

[Track & Confirm](#)

Track & Confirm

Search Results

Label/Receipt Number: 9171 0821 3339 3594 6365 44
Status: **Delivered**

Your item was delivered at 3:37 pm on January 10, 2009 in SANFORD, NC 27332. A proof of delivery record may be available through your local Post Office for a fee.

Additional information for this item is stored in files offline.

[Restore Offline Details >](#)



[Return to USPS.com Home >](#)

Track & Confirm

Enter Label/Receipt Number.

MAP DEPICTING LOCATION OF PROPERTY

Property Owner: Betty R Smith c/o Charles A Smith
1395,1399,1403,1407 Tom Starling Rd. Hope Mills, NC
MINIMUM HOUSING CASE # MH 5716 & 5617-2008

TAX PARCEL IDENTIFICATION NUMBER: 0433-85-2853 & 0433-85-4831

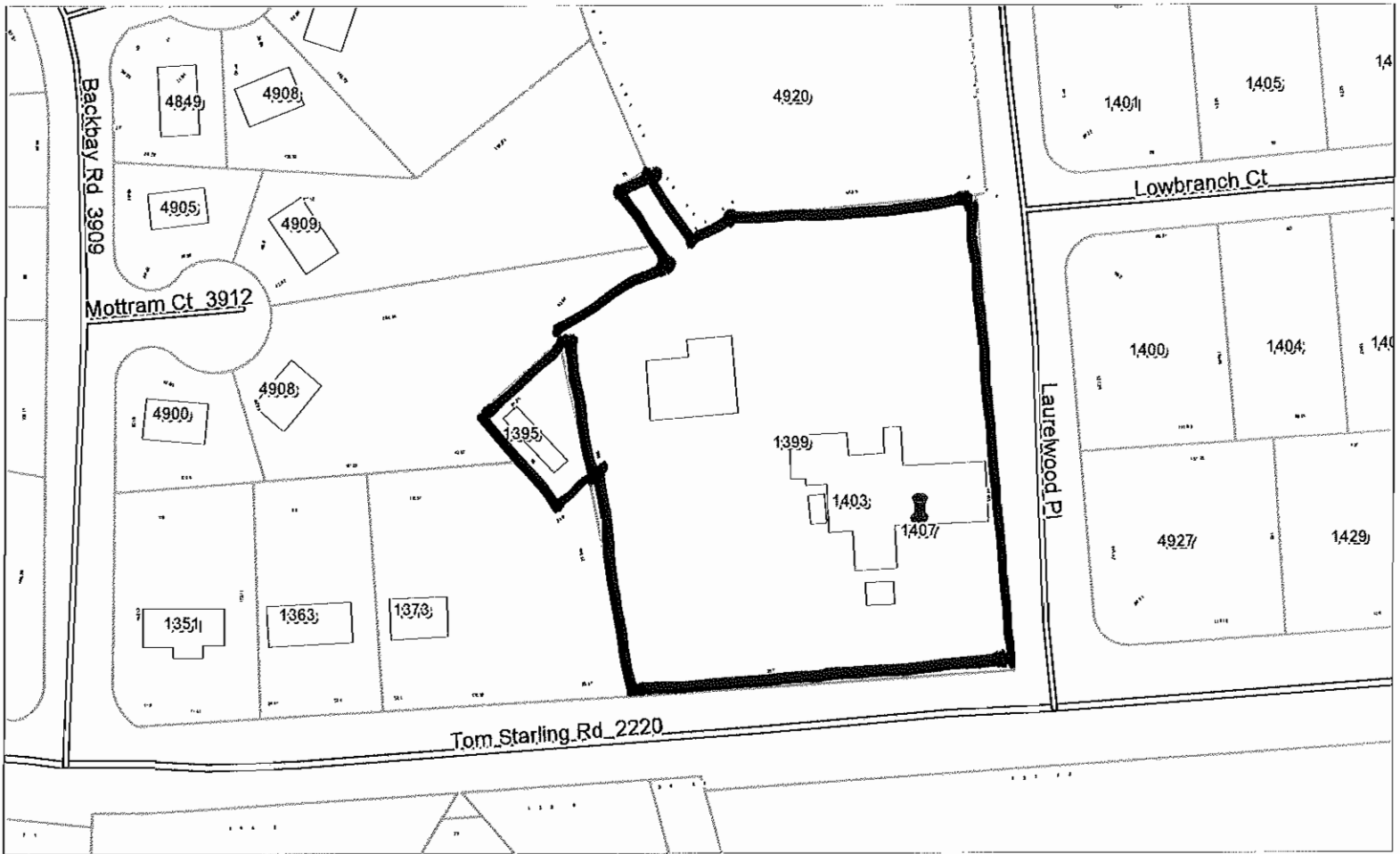

EXHIBIT B

Donovan McLaurin,
Chair
Wade, Falcon & Godwin

Lori Epler,
Vice-Chair
Cumberland County

Garland C. Hostetter,
Town of Spring Lake
Harvey Cain, Jr.,
Town of Stedman
Patricia Hall,
Town of Hope Mills
Charles C. Morris,
Town of Linden



CUMBERLAND
COUNTY



COUNTY of CUMBERLAND

Planning and Inspections Department

Thomas J. Lloyd,
Director

Cecil P. Combs,
Deputy Director

Walter Clark,
Roy Turner,
Sara E. Piland,
Cumberland County

Benny Pearce,
Town of Eastover

APRIL 10, 2009

ITEM NO. 2K

MEMO TO: Cumberland County Board of Commissioners

FROM: Cumberland County Joint Planning Board

SUBJECT: Consideration of the Cumberland County 2030 Growth Vision Plan and the Land Use Policies Plan, both documents are intended to give direction to all County and Municipal Governments within Cumberland County in reviewing development proposals, planning growth-related facilities and services, preparing standards and regulations, working together on growth management issues, and establishing applicable budget and work program priorities.

ACTION: Members present at the April 7, 2009 meeting voted unanimously to recommend approval of the 2030 Growth Vision Plan and the Land Use Policies Plan.

MINUTES OF APRIL 7, 2009

Vice-Chair Epler made a motion to recommend approval of the 2030 Growth Vision Plan and Land Use Policies Plan and forward to the Board of Commissioners, seconded by Mr. Hostetter. Unanimous approval

CUMBERLAND COUNTY

Land Use Policies Plan



**Cumberland County, Hope Mills, Spring Lake, Eastover, Stedman,
Wade, Falcon, Linden, and Godwin**



CONTENTS

INTRODUCTION	1
OVERVIEW	2
RESIDENTIAL DEVELOPMENT	3
Objectives	3
High Density Residential	4
Medium Density Residential	4
Low Density Residential	5
Suburban Density Residential	5
Rural Density Residential	5
COMMERCIAL DEVELOPMENT	6
Objectives	6
Light Commercial	7
Heavy Commercial	7
SHOPPING CENTER DEVELOPMENT	8
Activity Node	8
Regional Shopping Center	8
Community Shopping Center	11
Neighborhood Shopping Center	12
Area Center	13
BUSINESS STREET DEVELOPMENT	16
Primary Business Street Development	17
Designated Primary Business Street Development	18
Limited Business Street Development	19
Designated Limited Business Street Development	21
MIXED USE DEVELOPMENT	22
OFFICE AND INSTITUTIONAL DEVELOPMENT	23
Objectives	23
INDUSTRIAL /MANUFACTURING DEVELOPMENT	24
Objectives	24
Light Industrial/Manufacturing Development	24
Heavy Industrial/Manufacturing Development	25
OPEN SPACE	26
Objectives	26
AGRICULTURAL	27
Objectives	27
LAND USE POLICIES MATRIX	28

INTRODUCTION

In the late 1970's, the Cumberland County Joint Planning Board adopted a Land Use Policies Plan as an adjunct to the 1971 Cumberland County Land Use Plan, or the "1990 Plan". Since the 1990 Plan was a very general land use plan, it required additional data to determine specific land uses when considering zoning changes on individual parcels. The 2030 Growth Vision Plan is also a general plan that will require more specificity for determining land use for individual parcels. This document is applicable to the unincorporated portion of the County, and all the jurisdictions that are members of the Cumberland County Joint Planning Board. These jurisdictions include Hope Mills, Spring Lake, Eastover, Stedman, Wade, Falcon, Linden, and Godwin.

The purpose of the 2008 Cumberland County Land Use Policies Plan is to provide some guidance for local governing bodies in determining parcel land use decisions. It provides objectives and location criteria for residential uses, which includes: rural, suburban, low, medium and high density residential; commercial uses, which includes: light and heavy commercial, activity node, and regional-community-neighborhood-area shopping centers; mixed use development; office and institutional uses; industrial and manufacturing, which includes: light and heavy industrial/manufacturing uses; open space use; and agricultural use. This Plan dove-tails with the Urban Services and Municipal Influence Areas outlined in the 2030 Growth Vision Plan. It will also support the Transitional Use and Zoning Policy.

Cumberland County currently has numerous streets that are predominantly strip commercial and some that are in transition from residential streets to non-residential streets. It should be understood that the primary land use policy is that no new strip commercial areas be created. The Plan will look at land use on the existing streets and classify them as either a business street, residential street or transitional street. Existing strip commercial areas on major thoroughfares will be classified as a business street. Business streets will be broken down into two sub-categories – Primary and Limited.

The Planning staff, Planning Board, and elected bodies will use the information in this document as part of the data used to make zoning decisions. It is not the intent of this document to lock the Planning Board or elected officials into being forced to make a certain decision based on the criteria outlined. The criteria outlined in this document are a general guide and all criterions for the various uses do not need to be met for a favorable decision. In some cases other data may be more valuable and play a greater role in the decision making than the criteria outlined in this document and it is hoped that all of these jurisdictions will use this document as a primary tool for making zoning changes. This will aid in the provision of continuity and consistency in land use throughout the County.

OVERVIEW

It is important to understand the significance and purpose of this Land Use Policies Plan in the context of its role in planning and development in the County and the affected jurisdictions. The 2010 Land Use Plan defined the "urban form" for the County as a "Nodal Corridor" type. An illustration of this type "urban form" is as shown in **Exhibit 1 - Nodal -Corridor Urban Form**. Urban form is the type of development pattern resulting from the relationship between the man-made

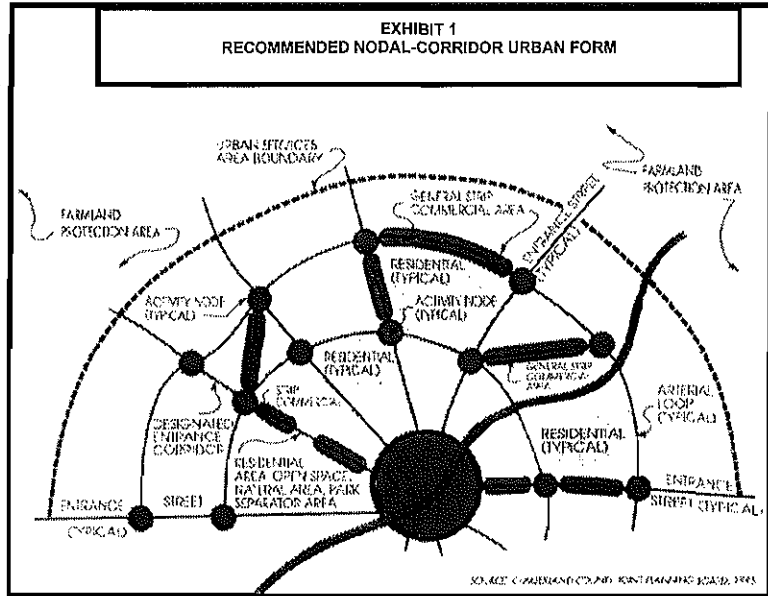

and natural environment. It guides the location, intensity, and type of development. It should be reflective of the unique economic climate, established development patterns, availability of resources, political philosophies and the desires and aspirations of residents in the impacted jurisdiction. The "Nodal Corridor" Urban Form calls for concentrated development to be located in nodes at major intersections and these nodes are connected by existing strip development. Future nodal non-residential development in the County and the affected jurisdictions will not have strip development as a connector. While the policy is not to create any new strip commercial areas, there can be exceptions based on changing conditions and market forces. Nodes should contain a

minimum, the most basic services needed by residents in the area.

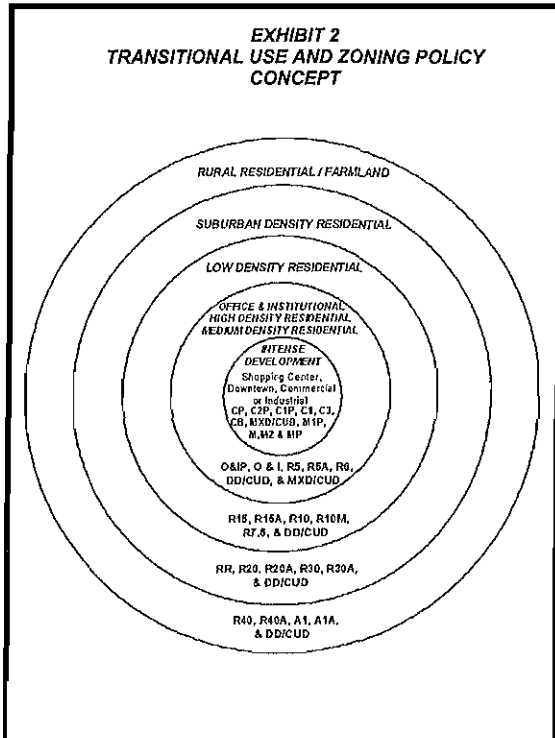

Implementation of the "Nodal Corridor" Urban Form requires some assurances that the uses in the nodes are compatible with each other and the node is compatible with the neighborhood. The Transitional Use and Zoning Policy provides a transition from intense commercial activity to low intensity activities. **Exhibit 2 – Transitional Use and Zoning Policy** illustrates this concept. It is based on the assumption that intense commercial development is more compatible with office and institutional, medium and high density residential uses. The top half of the circle indicates the various land uses and their intensity. The bottom portion of the circle indicates the corresponding zoning districts. This concept is applied in the treatment of zoning around the various types of shopping centers and activity nodes.

RESIDENTIAL DEVELOPMENT

The Land Use Policies Plan should complement the 2030 Growth Vision Plan Residential goals, which are addressed in the Objectives in this document. Planning for residential development in the affected jurisdictions involves determining not only the density type and location of the development; but also residential development's relationship with other land uses and various densities of residential development. Residential development is grouped into 5 categories based on density. Each residential type has specific location criteria. It must be understood that this criteria is only a guide and must be considered with other criteria when utilized to make zoning or planning decisions.

OBJECTIVES

Land Use Planning Objectives focus on the future residential development desires of Cumberland County residents. The location criteria outlined in this section should address or relate to accomplishing these objectives. Listed below are the Land Use Planning Objectives for Residential Development:

- Promote the removal of dilapidated housing
- Promote improvement of substandard housing
- Promote measures to stabilize and maintain existing residential neighborhoods
- Promote efforts that encourage the development of new housing stock
- Improve the quality of life in residential areas
- Promote residential development that is more environmentally and people friendly
- Promote the highest density in areas with all the urban services
- Promote infill development
- Provide an assortment of housing types and neighborhoods to meet the needs of all residents in the County

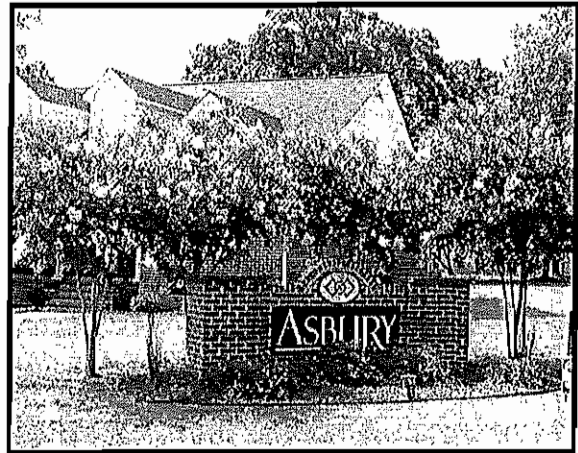

RESIDENTIAL DEVELOPMENT

High Density Residential

Definition

High Density Residential is defined as having a density of 15 or more units per acre. The zoning district classification for this type of development is R5 Residential District.

Location Criteria

- Public water and sewer required
- Desirable to be within one-half mile of a neighborhood, community, or regional shopping center
- Desirable to be adjacent to existing or zoned medium or high density development, office and institutional, or light commercial use
- Desirable to be within one-quarter mile of an existing major or minor thoroughfare
- Must have direct access to a collector street
- Desirable to be within two miles of a public recreation area
- Must not be located in any critical area as defined by the Fort Bragg Small Area Study and Fayetteville Regional Airport Plan
- Desirable to be located in vertical mixed use development
- Desirable to be a transition between non-residential and lower density residential areas
- Development in areas with hydric soils is discouraged

Medium Density Residential

Definition

Medium Density Residential is defined as having a density of greater than 6 and less than 15 units/acre. The zoning district classifications for this type of development are: R5A, R6, and R6A Residential Districts.

Location Criteria

- Public water and sewer required
- Desirable to be within two miles of an existing major or minor thoroughfare
- Must have direct access to a collector street
- Desirable to be within two miles of a public recreation area
- Must not be located in any defined critical area as defined by the Fort Bragg Small Area Study and Fayetteville Regional Airport Plan
- Desirable to be located in vertical mixed use development
- Desirable to be a transition between non-residential, higher density and lower density residential areas
- Development in areas with hydric soils is discouraged

RESIDENTIAL DEVELOPMENT

Low Density Residential

Definition

Low Density Residential is defined as having a density of 2.2 to 6 units/acre. The zoning district classifications for this type of residential development include: R7.5 and R15 Residential Districts.

Location Criteria

- Public or community water and public sewer required
- Must have direct access to a public street
- Desirable to be within three miles of a recreation area or facility
- Must not be located in any defined critical area as defined by the Fort Bragg Small Area Study
- Desirable to not be located in the Special Flood Hazard Area (100-year Flood Area)
- Desirable to be located in vertical mixed use development
- Must not be an area with hydric soils unless sewer is available

Suburban Density Residential

Definition

Suburban Density Residential can be defined as less than 2.2 units/acre and greater than one. The zoning district classifications for this type of residential development include: R20, RR, R20A, R30, & R30A Residential Districts.

Location Criteria

- Septic system allowed based on soil type, lot size, and distance from public sewer
- Must have direct access to a public street
- Must not be located in any defined critical area as defined by the Fort Bragg Small Area Study

Rural Density Residential

Definition

Rural Density Residential can be defined as one or less unit per acre. The zoning district classifications for this type of residential development include: R40, R40A, A1A, & A1 Districts.

Location Criteria

- Individual well and septic system
- Could be located in any defined critical area as defined by the Fort Bragg Small Area Study
- Desirable to be limited to 1 unit per acre in areas with hydric and severe septic tank limitations soils
- Desirable to not be located in an area that is a prime industrial site
- May be outside the Sewer Service Area

COMMERCIAL DEVELOPMENT

Developing policies for Commercial Development first requires defining the various types of commercial development. The Land Use Policies Plan defined commercial development as General Commercial Development, Shopping Center Development, Business Street Development and Central Business Development. General Commercial Development is any commercial development that is not located in a defined shopping center or in a defined business street segment. Shopping Center Development is commercial development which is planned, developed, operated and controlled as a unit with sufficient off street parking to jointly serve all establishments in the center. Business Street Development (Strip Development) consists of independent retail and offices which stand on parcels under separate ownership along a thoroughfare. Central Business Development is too complex and not addressed in this document. This section of the Land Use Policies Plan addresses location criteria, provides a working definition for each type, and outlines the commercial zoning districts and their relationship to the types of commercial development.

Objectives

Land Use Planning Objectives are strategic planning actions designed to accomplish a desired result for a specific land use within a planning area. Listed below are the Land Use Planning Objectives for Commercial Development:

- Promote the re-development of deteriorating commercial areas
- Promote efforts that encourage new commercial development
- Promote policies that address the expansion of strip commercial areas with respect to landscaping, access, and buffering
- Provide sufficient zoned commercial areas to accommodate the needs of County residents
- Promote pedestrian friendly commercial development
- Promote the highest concentration of commercial development at major interchanges and intersections
- Locate commercial development so that it has the least impact on residential and other non-compatible uses
- Reduce regulatory measures that hinder commercial development

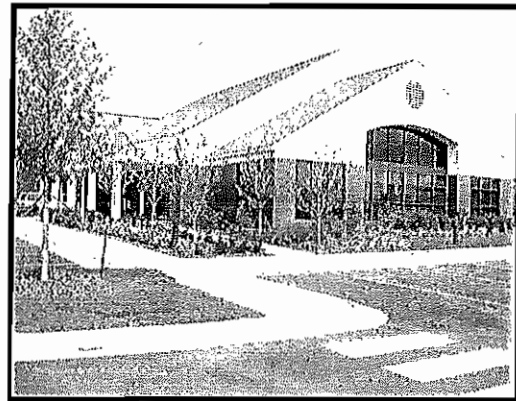

GENERAL COMMERCIAL DEVELOPMENT

Light Commercial

Definition

Light Commercial can be defined as uses that provide convenience goods and services for the immediate neighborhood. Zoning district classifications for this type of development includes: C-1, C1(P) & C2(P) Commercial Districts.

Location Criteria

- *Public water and sewer required
- Must have direct access to a collector street
- Should serve as a transition between heavy commercial, office & institutional or residential development
- *Should have other light commercial uses in the area
- Should provide convenient goods and services to the immediate surrounding neighborhood
- *May be located along a street that is in transition from residential to non-residential through redevelopment and physical improvements
- May be located in an Activity Node or in a designated heavy commercial area
- May be located in a rural area at the intersection of two collector streets ("Mom & Pop" country store)

* Except for Rural Commercial

Heavy Commercial

Definition

Heavy Commercial can be defined as uses that provide a wide variety of retail, wholesale and commercial businesses. Zoning district classifications for this type of development include: C-3, C(P) & CBD Commercial Districts.

Location Criteria

- Public water and sewer required
- Should have minimum direct access to a collector street
- Should not be in a predominantly residential, office & institutional, or light commercial area
- May be co-located with light industrial/manufacturing uses
- Must be located on a sufficient site that provides adequate area for buffering, screening, and landscaping
- Could be located in a designated Activity Node area

SHOPPING CENTER DEVELOPMENT

Shopping centers generate high levels of non-residential activities and significant traffic volumes which have the potential of a negative impact upon surrounding land uses. Defining shopping centers by type and creating specific location criteria for each type will allow for adequate planning of these facilities in order to minimize negative impacts to the surrounding area. These specific types and location criteria are listed below.

Activity Node

Definition

An Activity Node is defined as an area at the intersection of two major thoroughfares or at interchanges that has the potential for a concentration of non-residential or a large mixed use development. Zoning district classifications for this type of development include: MP, CP, and M2 Districts.

Location Criteria

- Public water and sewer required
- Should have direct access to a collector street and border a major thoroughfare
- May consist of any commercial use, light & heavy industrial/manufacturing uses as a core or a concentrated large mixed use development
- Must be a tract of sufficient size to provide adequate area for buffering, screening, and landscaping

Regional Shopping Center

Definition

A regional center is built around two full-line department stores each with a floor space of over 100,000 square feet, junior department store, mass merchant, discount department store, and fashion apparel. Regional centers are built around two or more anchors with the anchors consuming 50-70 percent of the total space. It generally has a gross leasable area between 400,000 and 800,000 square feet on 40 to 100 acres. Its trade area is a minimum of 30,000 households. The distance of its drawing power is restricted only by such factors as competitive shopping facilities and travel time over limited access highways (usually 10 minutes to 1 hour) or 5 to 15 miles.

Location Criteria

- Public water and sewer required
- Should be a minimum of 50 acres
- Bordered by a major arterial street that provides regional accessibility
- Should have a direct access to a collector street and border a major thoroughfare
- May be located in a designated Activity Node area

SHOPPING CENTER DEVELOPMENT

Regional Shopping Center Policy Bordering on Two Major Arterial Streets

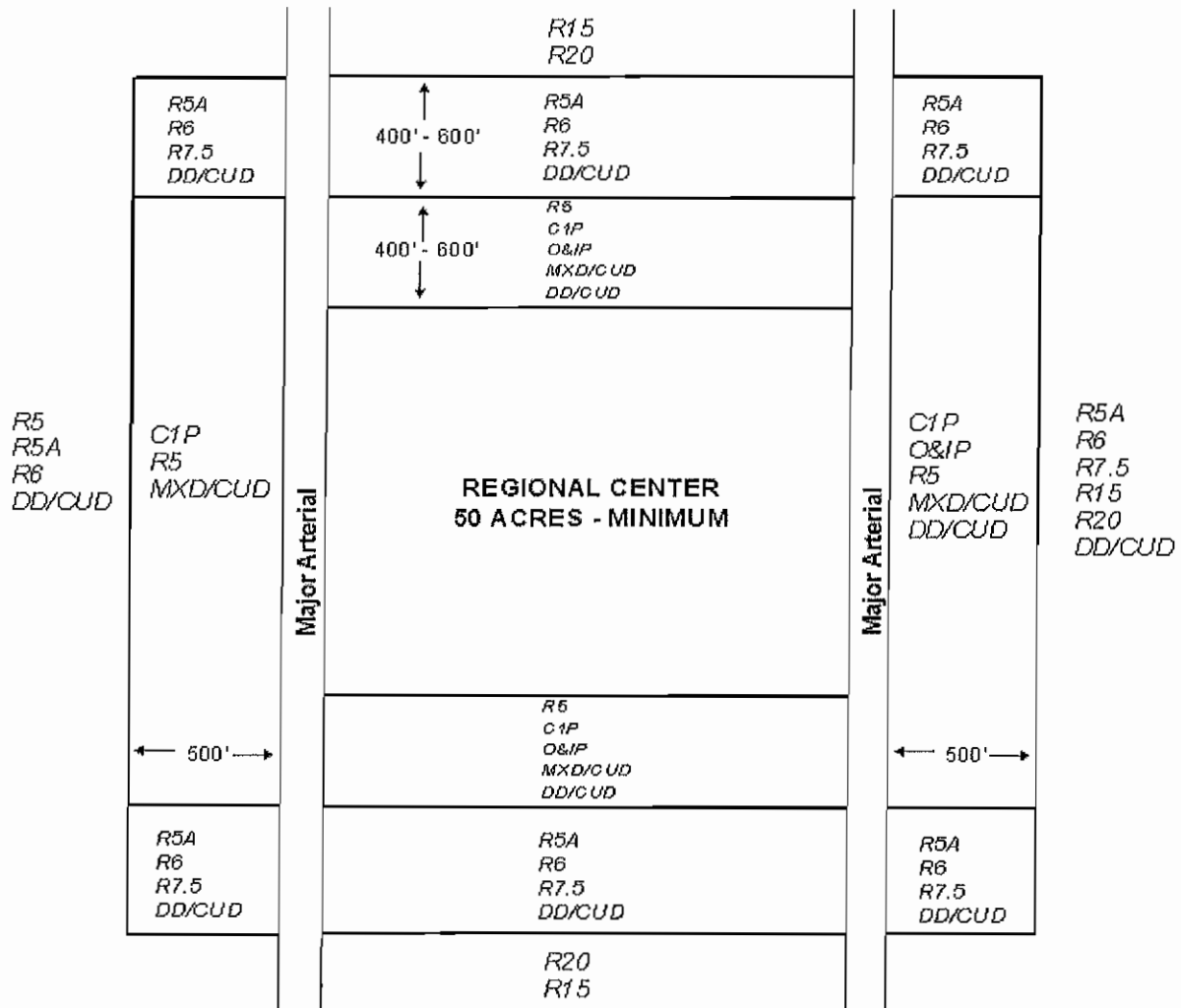

SHOPPING CENTER DEVELOPMENT

Regional Shopping Center Policy at the Intersection of Two Major Arterial Streets

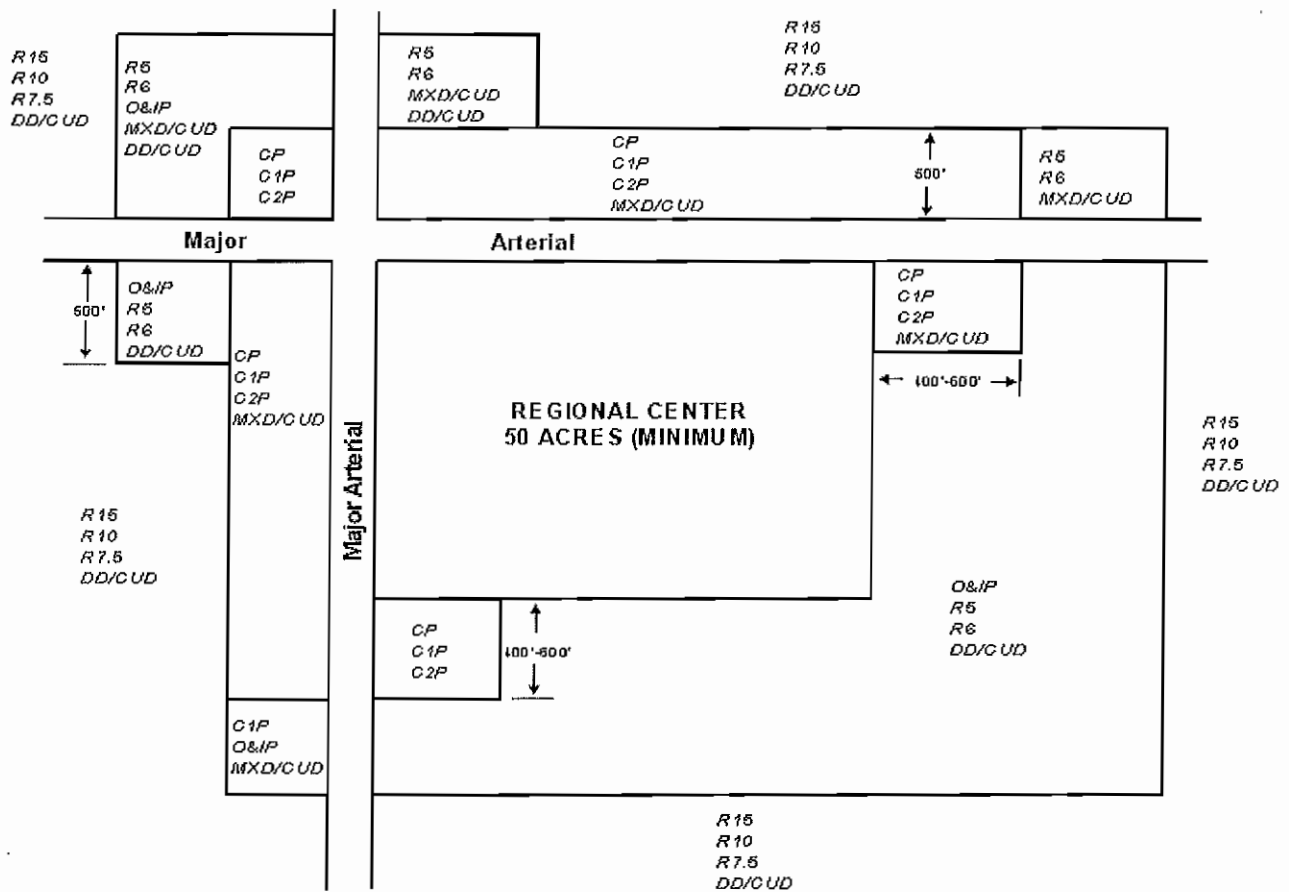

SHOPPING CENTER DEVELOPMENT

Community Shopping Center

Definition

A Community Shopping Center is built around a discount department store with other tenants being a variety store, drug store, home improvement, large specialty/discount apparel, and super market. It generally has a gross leasable area between 100,000 to 350,000 square feet on 10 to 40 acres. Anchors consume between 40 and 60 percent of the floor area. Its trade area serves 12,000 to 30,000 households within a three to six mile distance.

Location Criteria

- Public water and sewer required
- Should be a minimum of 10 acres
- Bordered by at least two minor arterial streets or by a collector and an arterial street
- May be located in a designated Activity Node area
- Must be located on a sufficient site that provides adequate area for buffering, screening, landscaping, parking, etc.

Community Shopping Center Policy at the Intersection of Two Arterial Streets

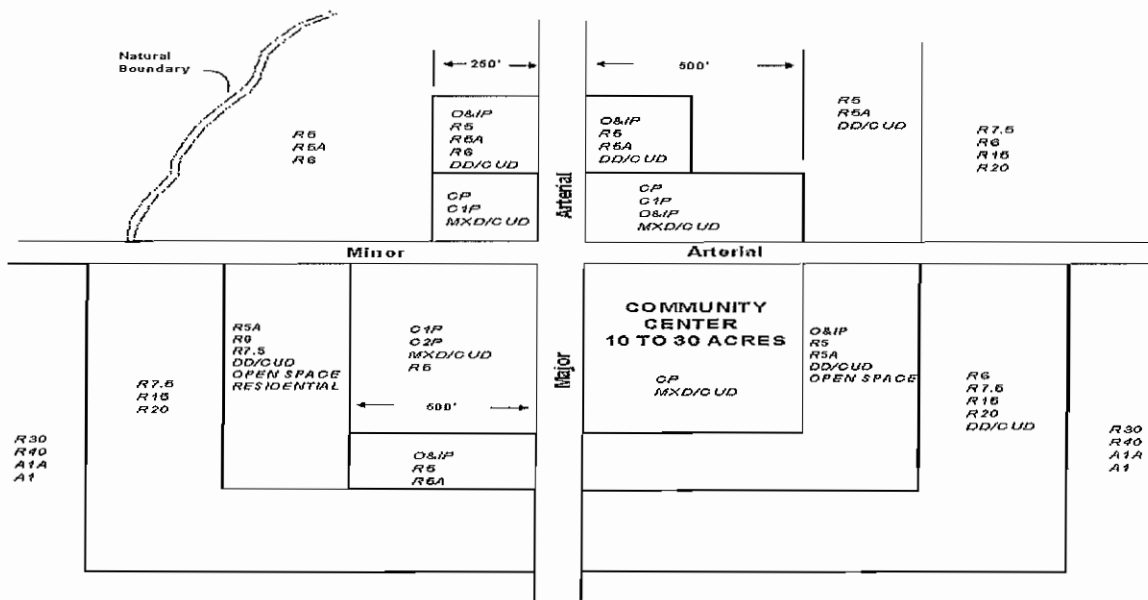

SHOPPING CENTER DEVELOPMENT

Neighborhood Shopping

Definition

A Neighborhood Shopping Center is built around a supermarket or variety store as a principal tenant. In addition to convenience goods and personal services, this center also provides a very limited range of shopper goods such as hardware and ready-to-wear clothing. Neighborhood centers range in size from 30,000 to 150,000 square feet of gross leasable area on 3 to 15 acres. They usually consist of one or more anchors occupying between 30 and 50 percent of the leasable area. Its trade area serves 2,500 to 12,000 households within a one to three mile distance.

Location Criteria

- Public water and sewer required
- Should be 4 - 10 acres
- Bordered by at least an arterial and a collector street
- Should have 3000+ households within a 5-10 minute drive market area
- Must be located on a sufficient site that provides adequate area for buffering, screening, landscaping, parking, etc.

Transitional Zoning Policy for a Neighborhood Shopping Center

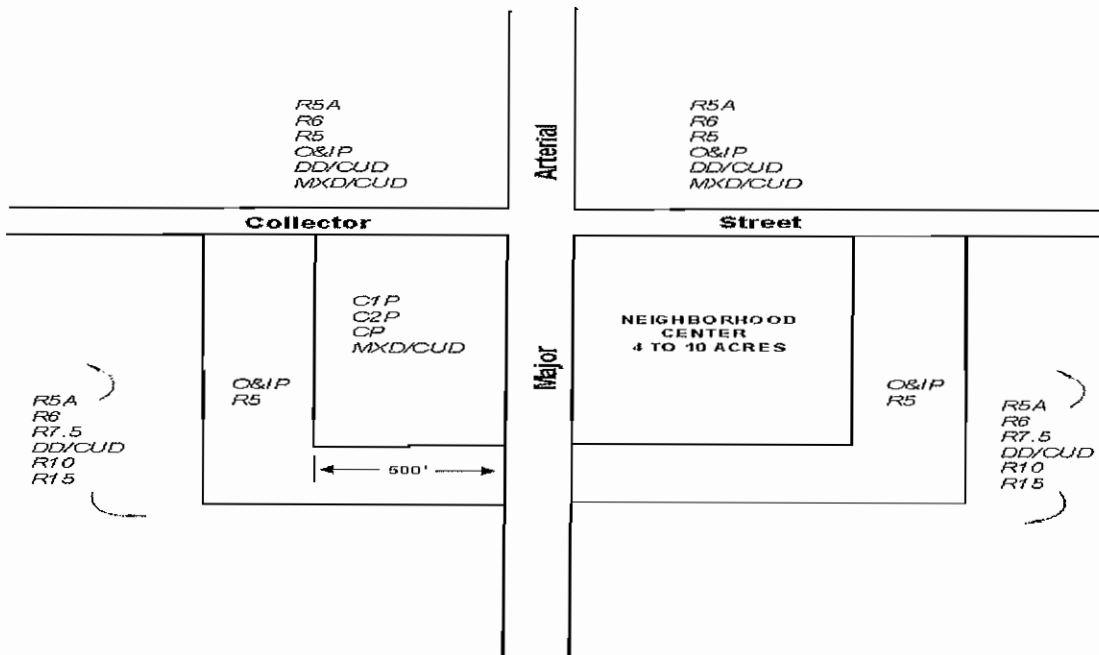

SHOPPING CENTER DEVELOPMENT

Area Center

Definition

An Area Shopping Center is built around a small grocery store or convenience store that provides convenience goods for daily living needs.

Location Criteria

- Public or community water and sewer service desirable
- Should be minimum of 2.5 acres
- Bordered by at least a collector street
- Must be located on a sufficient site that provides adequate area for buffering, screening, landscaping, parking, etc.
- May be a “Mom & Pop” country store in the rural area



SHOPPING CENTER DEVELOPMENT

Shopping Center Classifications

Community Center:

Cumberland County

1. Black & Decker Road and Legion Road
2. NC Highway 24 and Maxwell Road
3. NC Highway 87 and Sandhill Road

Hope Mills

1. Camden Road and N. Main Street (Hope Mills Road)

Spring Lake

1. Lillington Highway (Super Wal-Mart)
2. N. Bragg Boulevard (Southwind Plaza)

Eastover

1. Dunn Road at Middle Road and Baywood Road intersections

Stedman

1. Clinton Road at Wade-Stedman Road and Bainbridge Road intersections

Neighborhood Center:

Cumberland County

1. Cumberland Road and Hope Mills Road
2. Ramsey Street and Elliot Bridge Road

Area Center:

Cumberland County

1. Lillington Highway and Manchester Road
2. Maxwell Road and Wade-Stedman Road
3. NC Highway 13 and Wade-Stedman Road
4. Cedar Creek Road and Tabor Church Road/Stedman-Cedar Creek Road
5. NC Highway 210S and NC Highway 242

Hope Mills

1. South Main Street and Parkton Road

Activity Node:

Cumberland County

1. I-95 and Goldsboro Road (NC Highway 13) Interchange (Unincorporated area)
2. I-95 and Cedar Creek Road (NC Highway 53) Interchange

SHOPPING CENTER DEVELOPMENT

Shopping Center Classifications

Activity Node continued:

Hope Mills

1. I-95 and Chicken Foot Road Interchange

Eastover

1. I-95 and Goldsboro Road (NC Highway 13) Interchange
2. I-95 and Murphy Road Interchange

BUSINESS STREET DEVELOPMENT

Over the years, Cumberland County has experienced a tremendous amount of commercial development. In many instances, this commercial development occurred along streets that were once rural in character, residential in character, and transformed them into major thoroughfares. Due to this evolution, a Business Street Policy is established, which will designate certain segments of thoroughfares and collector streets as either Limited or Primary Business Streets. After a street is designated as either a primary or limited business street, this policy will address how adjacent development will be treated.

Strip commercial development is a viable part of commercial development in the County. It provides jobs; is conducive for certain types of commercial uses such as car lots, gas stations, fast food restaurants, etc; provides retail and other services the public demands; and it often provides an incubator for business start-ups. The Business Street Concept is a way of acknowledging existing strip commercial development and limiting the creation of any new strip development. This existing strip development should not contain an entire road segment, but be broken up by residential, institutional, open space or natural areas. It should be limited to 1/2 mile segments or to nearest natural area or viable residential area. Future plans should be developed to address specific design standards for strip commercial development.

Designated Business Street Location Criteria

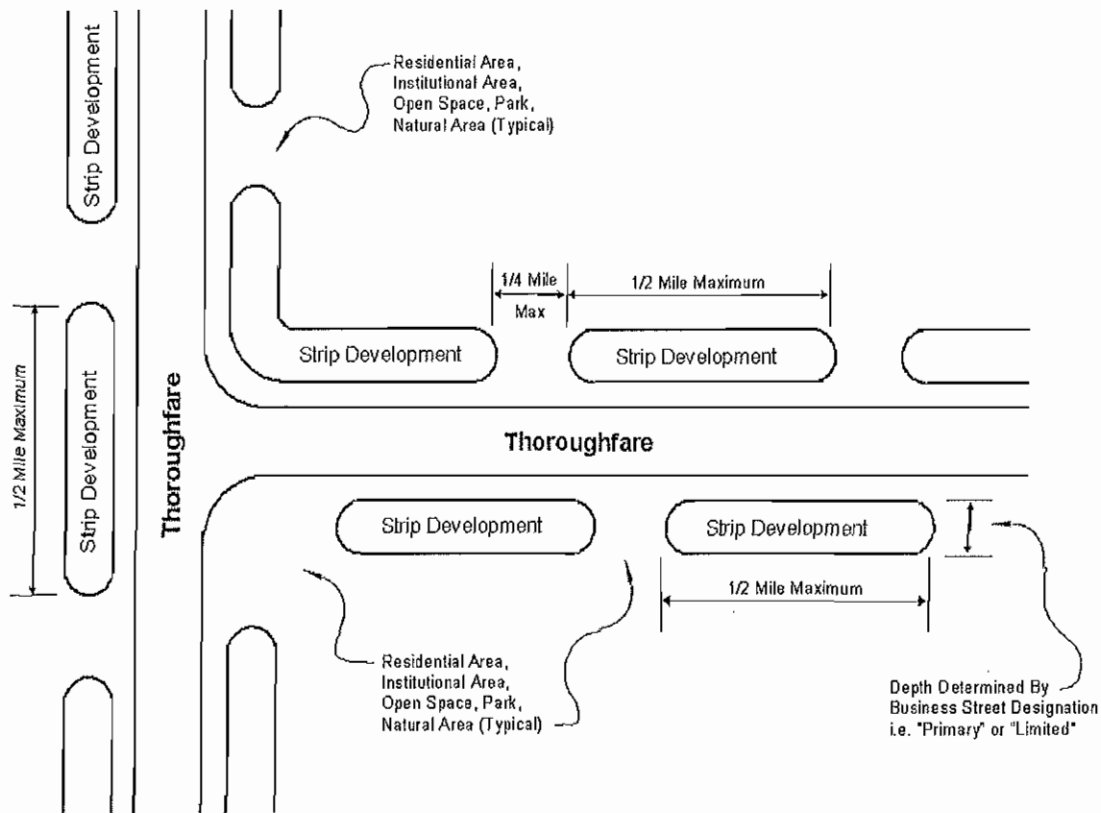

BUSINESS STREET DEVELOPMENT

Primary Business Street

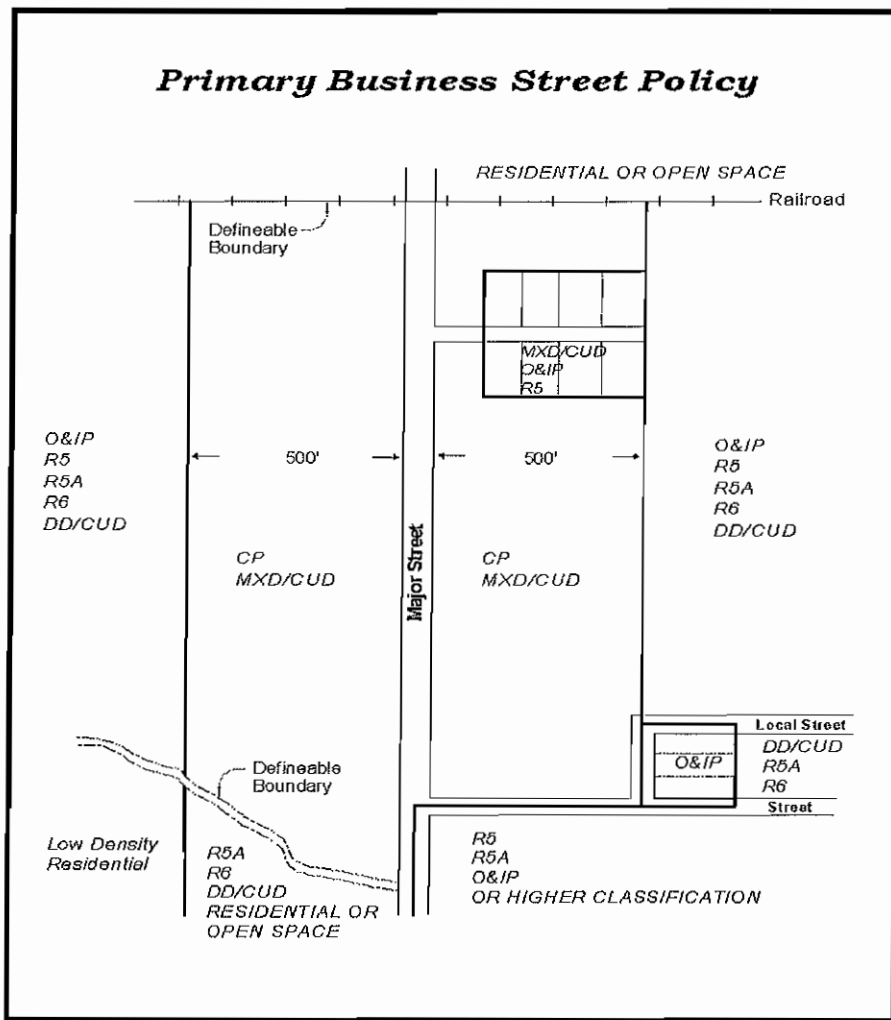

BUSINESS STREET DEVELOPMENT

Designated Primary Business Street

Cumberland County

1. Both sides of Cumberland Road from Boone Trail eastward to Fayetteville City Limits.
2. Both sides of Gillespie Street from just North of Linwood Road to East Mountain Drive.
3. Both sides of Eastern Boulevard from Fayetteville City Limits northward to Martin Luther King Boulevard.
4. Both sides of I-95 Business from South Main Street to Brooklyn Circle.
5. West side of Ramsey Street from Slocomb Road to just south of Wolfpointe Drive.
6. East side of Ramsey Street from Slocomb Road to Lou Drive.
7. Both sides of McArthur Road from Honeycutt Road to Andrews Road.
8. West side of Murchison Road from Shaw Road to Military Reservation.
9. Both sides of Clinton Road from I-95 overpass to the western loop of Bladen Circle.

Hope Mills

1. Both sides of Hope Mills Road from Camden Road north to Fayetteville City Limits.

Spring Lake

1. Both sides of Bragg Boulevard from southern Military Reservation to northern Military Reservation.
2. South side of NC Highway 210N/Lillington Highway from Bragg Boulevard to Waterway Drive.
3. Both sides of Murchison Road from Bragg Boulevard to Military Reservation.

Stedman

1. Both sides of Clinton Road from Magnolia Church Road to the eastern Town Limits.

BUSINESS STREET DEVELOPMENT

Limited Business Street

A Limited Business street designation should only be applied to an existing single family detached residential street that is in transition to a non-residential area. This transition is due to the deterioration in the suitability of a street segment for single family residential use. This could be due to changes in housing conditions, ownership patterns, existing zoning, zoning history, street design, non-conforming uses and existing land use.

Definition

A Limited Business Street typically has a series of narrow lots with a depth of 150 feet intended for residential use. Additionally, it is usually a street segment undergoing a transition from deteriorating conditions for residential uses to non-residential uses. These conditions include increased traffic volume along the road segment, which is classified as a collector or arterial street, and physical conditions of either the residential structures, or the neighborhood itself. The transition is usually from residential to small retail, service or office uses.

Location Criteria

- Should be within the Sewer Service Area
- Should be classified as an Urban or Major Rural Collector Street as defined in the Collector Street Plan for the Fayetteville Urbanized Area, 2004
- Should be a predominance of non-residential uses along the street segment and/or clearly demonstrated that the property in question is not suitable for residential use
- Lots along the street segment should have less than 200 feet of road frontage and a depth of 200 feet or less
- Limited Business Street designations may be limited to one side of the street when uses on the opposite side of the street will not be adversely affected

Limited Business Street Location Criteria

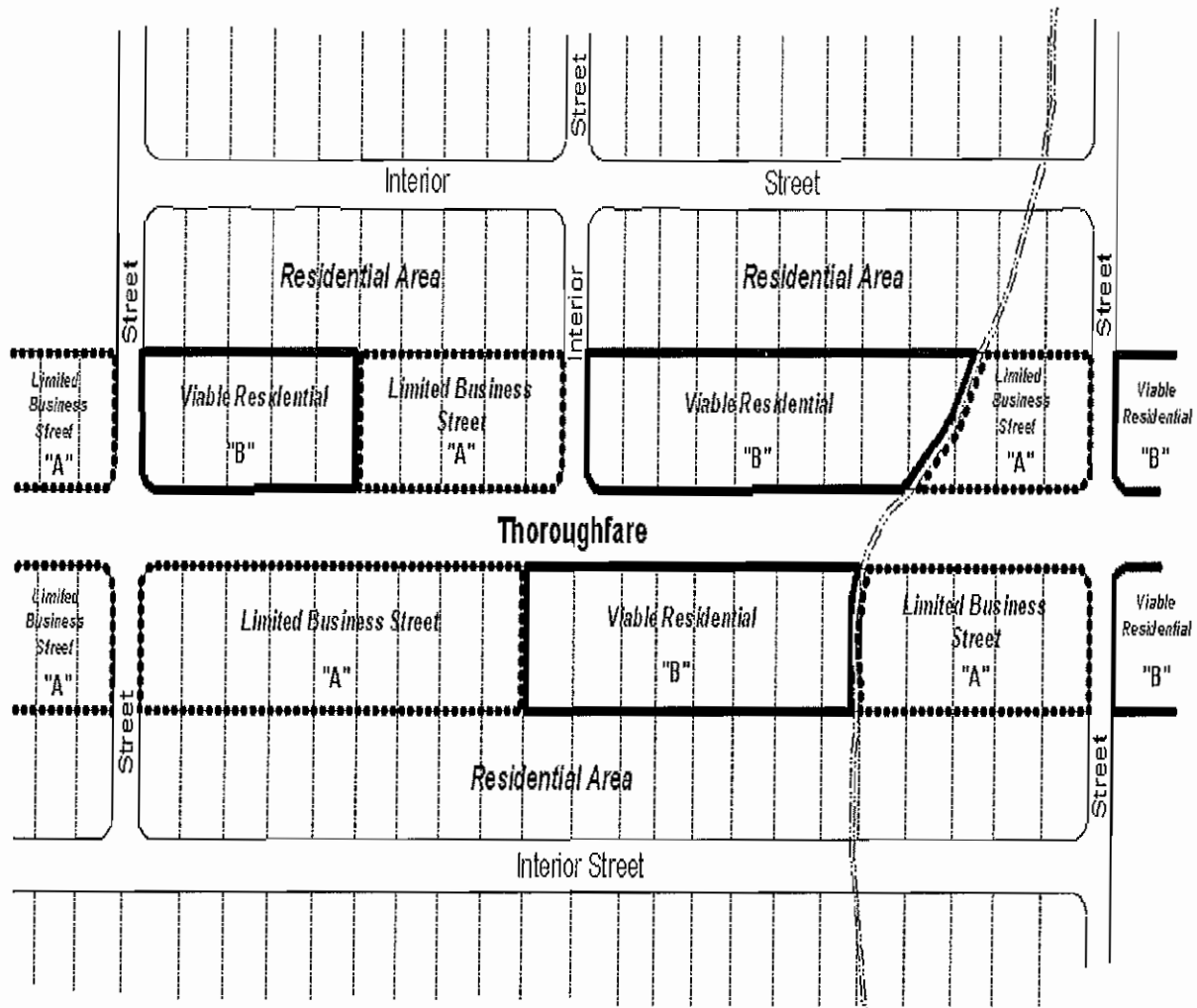

"A" - Deteriorating residential area that is in transition to light commercial or office (Limited Business Street).

1. All uses oriented to the thoroughfare.
2. No vehicular access to the interior streets.
3. Screening and fencing required along lot lines abutting residential area.
4. No thru traffic or parking lots allowed in the residential area.

"B" - Stable viable residential area to be preserved.

BUSINESS STREET DEVELOPMENT

Designated Limited Business Street

Cumberland County

1. Both sides of Boone Trail from Cumberland Road to Fayetteville City Limits.
2. Both sides of Cumberland Road from Wingate Road to Boone Trail.

Hope Mills

1. Both sides of Main Street from Butler Street to just south of McRae Street.

MIXED USE DEVELOPMENT

Mixed Use Development

Mixed Use Development can be found in three configurations: Vertical, Horizontal Attached and Horizontal Detached. Vertical Mixed Use is a single structure with the above floors used for residential or office use and the ground floor used for commercial. Horizontal Attached Mixed Use is a single structure which provides commercial use in the portion fronting a street with attached residential or office uses behind. Horizontal Detached Mixed Use is two or more structures on one site which provides commercial uses in the structure fronting the street and residential and office uses in separate structures behind or to the side.

Definition

Mixed Use Development refers to the combining of retail/commercial and/or service uses with residential or office use in the same building or on the same site.

Location Criteria

- Public or community water and sewer service required
- Should be minimum of 10 acres
- Located on a minimum designated collector street
- Must be located on a sufficient site that provides adequate area for buffering, screening, landscaping, parking, and required open space
- May be a "Mom & Pop" country store in the rural area
- May require a feasibility study submitted to justify that there are sufficient households in the development to support the commercial area
- Commercial uses should be oriented to residents in the development
- Sliding scale for commercial development
- Separation of mixed uses
- Is a means to promote an alternative to strip commercial development

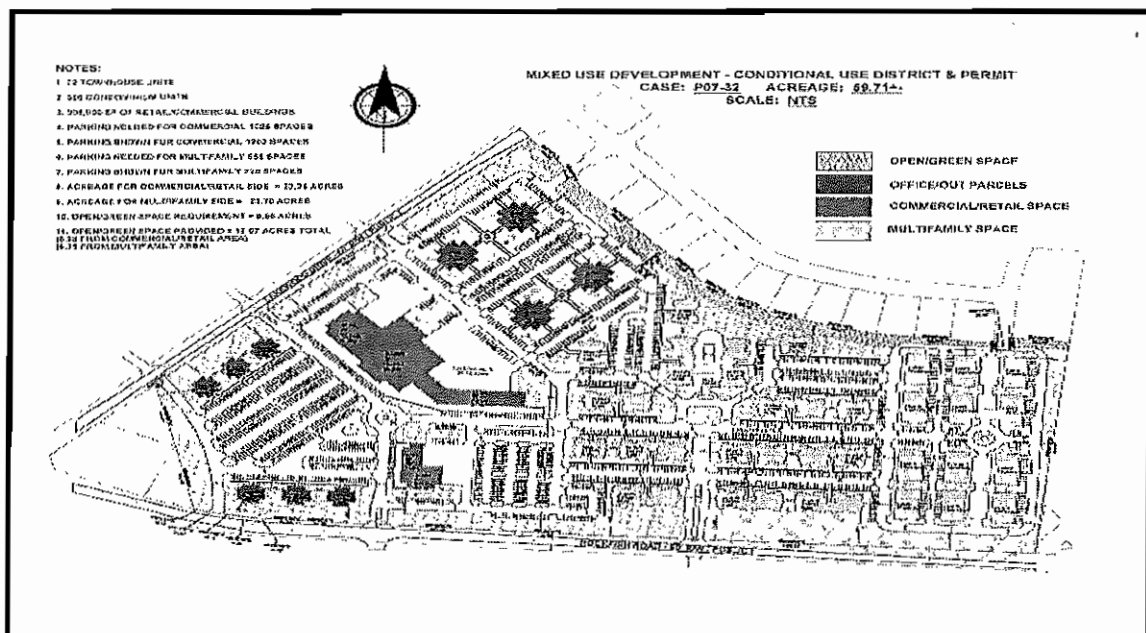

OFFICE & INSTITUTIONAL DEVELOPMENT

Office and Institutional Development has characteristics that require specific planning criteria, such as leasable square footage, services provided, minimum yard setbacks, off-street parking, provision of water and sewer and other utilities; access to public streets, sidewalks and bus routes. These planning criteria are specified within the Zoning and Subdivision Ordinances of each of the local jurisdictions and are site-specific. The Land Use Policies Plan contains Location Criteria, which group these planning criteria into broader categories to provide a method of finding general locations suited for Office and Institutional Development.

Objectives

Land Use Planning Objectives are strategic planning actions designed to accomplish a desired result for a specific land use within a planning area. Listed below are the Land Use Planning Objectives for Office and Institutional Development:

- Use office & institutional uses as a transition from commercial to residential development
- Promote efforts that encourage new office & institutional development
- Promote policies that concentrate office & institutional use in parks or clusters
- Provide sufficient zoned office & institutional areas to accommodate the needs of County residents
- Promote pedestrian friendly office & institutional development
- Reduce regulatory measures that hinder office & institutional development

Definition

General office uses and institutional uses serve as a buffer between commercial and residential development or are concentrated in a park. The zoning district classifications for this type of development are: Office and Institutional (O&I) and Planned Office and Institutional (O&I(P)).

Location Criteria

- Public water and sewer desirable
- Should have a direct access to a collector street
- If not developed in an office park, should serve as a transition between commercial and residential uses
- Must be located on a sufficient site that provides adequate area for buffering, screening, and landscaping

INDUSTRIAL /MANUFACTURING DEVELOPMENT

Planning for Industrial Development involves examining specific categories which are based upon density. Each category has characteristics that require specific planning criteria. These criteria include, but are not limited to: minimum yard setbacks, off-street parking, availability of water, sewer and other utilities; and access to public streets. These planning criteria are specified within the Zoning and Subdivision Ordinances of each of the local jurisdictions and are site-specific. The Land Use Policies Plan contains Location Criteria, which group these planning criteria into broader categories to provide a method of finding general locations suited for Industrial Development.

Objectives

This section contains the Land Use Planning Objectives for Industrial Development, and the definitions of industrial types, with their specific location criteria.

- Promote the re-development of deteriorating industrial areas
- Promote efforts that encourage new industrial development
- Prohibit residential development in prime industrial areas
- Provide sufficient zoned industrial areas to accommodate the needs of present and future County residents
- Promote the highest concentration of industrial development in areas that have existing, programmed or planned infrastructure
- Locate industrial development so that it has the least impact on residential and other non-compatible uses

Light Industrial /Manufacturing

Definition

Industrial and manufacturing operations that require a limited amount of land area, infrastructure and access and have very few noxious effects on the surrounding properties. The zoning district classifications for this type of development are: M1P, M1 and M Light Manufacturing Districts.

Location Criteria

- Public water and sewer desirable
- Should have a minimum direct access to a public street
- Should not be in a predominantly residential or office & institutional area
- Must be located on a tract that provides adequate area for buffering, screening, and landscaping unless located in an existing or proposed heavy industrial/manufacturing area
- Outside the Special Flood Hazard Area (100-year Flood Area)

INDUSTRIAL /MANUFACTURING DEVELOPMENT

Heavy Industrial/Manufacturing

Definition

Industrial and manufacturing operations that require a substantial amount of land area, infrastructure and access and have the potential for noxious effects on the surrounding properties. The zoning district classifications for this type of development are: MP and M2 Heavy Manufacturing Districts.

Location Criteria

- Public water and sewer required
- Should have a minimum direct access to an arterial street
- Should not be in a predominantly residential, office & institutional, or light commercial area
- Must be located on large tracts that provide adequate area for buffering, screening, and landscaping unless located in an existing or proposed heavy industrial/manufacturing area
- Outside the Special Flood Hazard Area (100-year Flood Area)

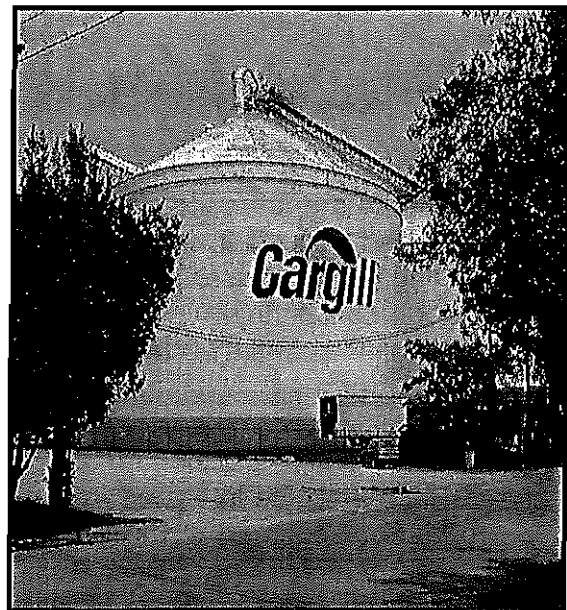

OPEN SPACE

Open Space, in a broad context, is considered to be a natural resource that is threatened by urban encroachment. The Zoning and Subdivision Ordinances of each of the local jurisdictions address Open Space through specific zoning districts and allowing certain uses within those districts. The Land Use Policies Plan contains Location Criteria, which provide a method of finding general locations suited for Open Space.

Objectives

- Protect and preserve environmentally sensitive areas and natural resources
- Protect wetlands, watercourses and watersheds from pollution
- Provide open space and recreation facilities near the population
- Protect and preserve wildlife habitat areas

Definition

Open Space is defined as land used for recreation, natural resource protection and buffer areas. The primary zoning district classification for this land use category is CD Conservancy District, although public/private recreation facilities operated not for profit, are allowed in all zoning districts if approved by the Board of Adjustment.

Location Criteria

- Should have a minimum direct access to a public or private street
- May be located in an environmentally sensitive area or part of the open space requirements for residential development
- Could include the Special Flood Hazard Area (100-year Flood Area)
- May be designated on the 2030 Growth Vision Plan Map as Conservation Area
- May be designated on the Fort Bragg Small Area Study as an Environmentally Sensitive Area

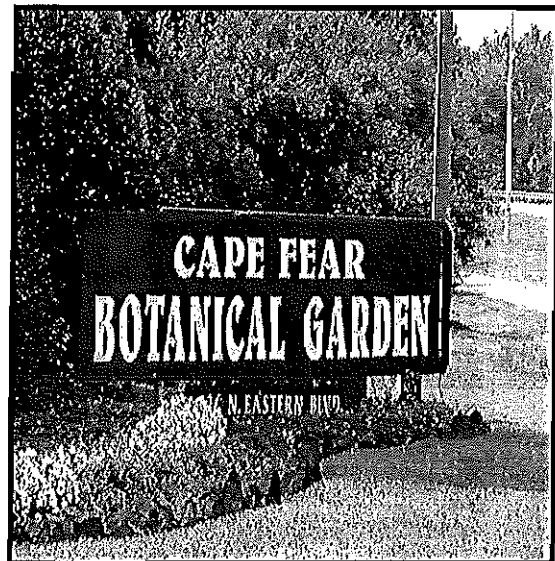
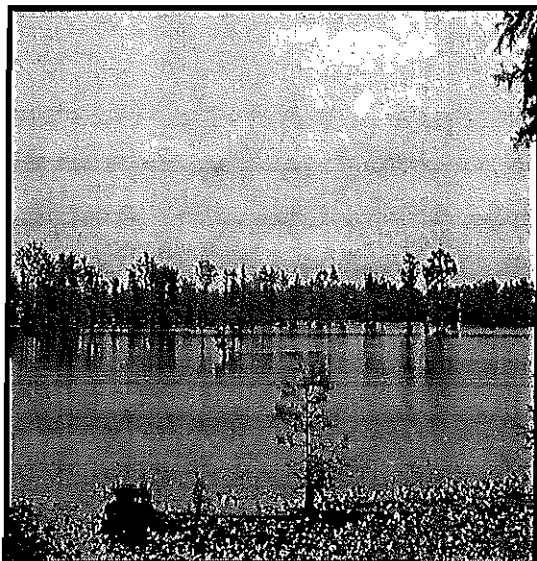

AGRICULTURAL

Agricultural land use, in a broad context, is considered to be a resource that is threatened by urban encroachment. The Zoning and Subdivision Ordinances of each of the local jurisdictions address Agricultural land use through specific zoning districts and allowing certain uses within those districts. The Land Use Policies Plan contains Location Criteria, which provide a method of finding general locations suited for Agricultural land use.

Objectives

- Promote the preservation of farmland areas
- Preserve the rural character of the County
- Protect farming and farming operations from urban encroachment

Definition

Agricultural is defined as land actively being used for farming and forestry purposes. The zoning district classifications for this type of land use are: A1 and A1A Agricultural Districts, although agriculture or rural farm use is allowed in all of the residential zoning districts and planned commercial and planned industrial districts.

Location Criteria

- Should be outside Sewer Service Area, but if inside it must be a bona fide farm
- Existing farm or agricultural operation
- Should meet criteria for Voluntary Agricultural District designation

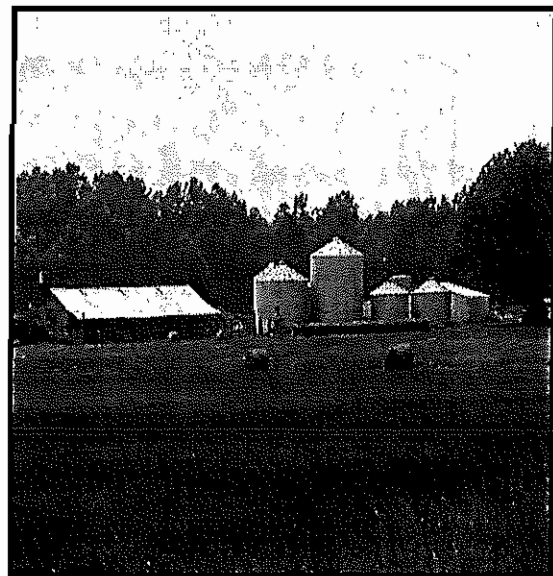
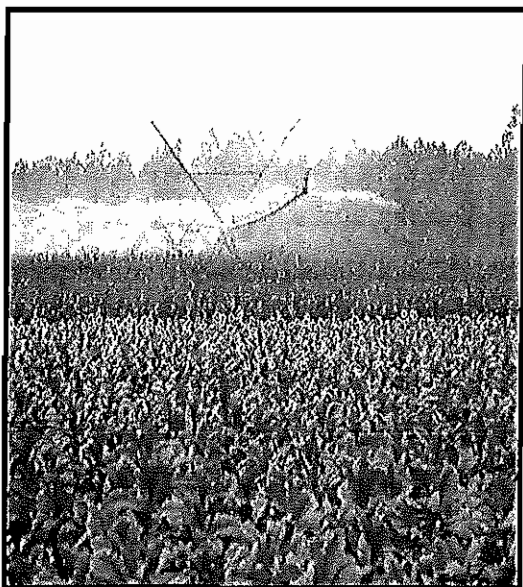

Definition

LAND USE POLICIES LOCATION CRITERIA MATRIX

CUMBERLAND COUNTY PLANNING DEPARTMENT

PLANNING BOARD

Mr. Donovan McLaurin, Chairman..... Falcon, Godwin & Wade
Mrs. Lori Epler, Vice Chairman..... Cumberland County
Mr. Garland C. Hostetter Spring Lake
Mr. Roy Turner..... Cumberland County
Mr. Walter Clark..... Cumberland County
Mr. Harvey Cain, Jr. Stedman
Mr. Charles C. Morris Linden
Mrs. Sara E. Piland Cumberland County
Mrs. Patricia Hall Hope Mills
Mr. Benny Pearce..... Eastover

ADMINISTRATIVE STAFF

Mr. Thomas J. Lloyd Planning & Inspections Director
Mr. Cecil P. Combs Deputy Planning & Inspections Director
Mrs. Laverne Howard Administrative Coordinator

ADDRESSING/STREET NAMING

Mr. Mike Osbourn GIS Coordinator
Mr. Ron Gonzalez Addressing Technician
Mr. Shane Parsons Planning Assistant
Mr. Lloyd Bigler..... Sign Shop Supervisor
Mr. William Phipps Planner II
Ms. Diane Shelton Street Name Coordinator
Mr. Steve Adams Sign Technician

GIS

Mr. Matthew Rooney, AICP GIS Manager
Mr. Lee Eanes, GIS Coordinator
Mrs. Mary Ann Steinmetz GIS Analyst

**COMPREHENSIVE PLANNING

Mr. Will Denning Planner III
Mrs. Hope Barnhart, AICP Planner II
Mrs. Denise Sykes..... Planner I
Mrs. Deloma West..... Planner I

GRAPHIC SERVICES

Ms. Donna McFayden Plat Review Officer
Ms. Annie Faircloth GIS Technician II
Mrs. Joyce McCullen..... GIS Technician I

LAND USE CODES

Ms. Patti Speicher..... Planner III
Mr. Ed Byrne..... Planner II
Mrs. Patricia Brooks Planner I
Mrs. Pier Varner..... Planner I
Mr. Jeff Barnhill..... Watershed Officer
Ms. Rita Perry Administrative Support

TRANSPORTATION

Mr. Rick Heicksen..... Planner III
Mrs. Maurizia Chapman, AICP Planner II
Mr. Bobby McCormick Planner I
Mr. Alvin Bess Planner I
Mr. Mark Nottingham..... Planner I
Mr. Michael Rutan..... Planner I
Mrs. Kristine Wagner Community Transportation Planner
Ms. Kelly Raymes..... CTP Assistant

**Section responsible for this report
January 2009

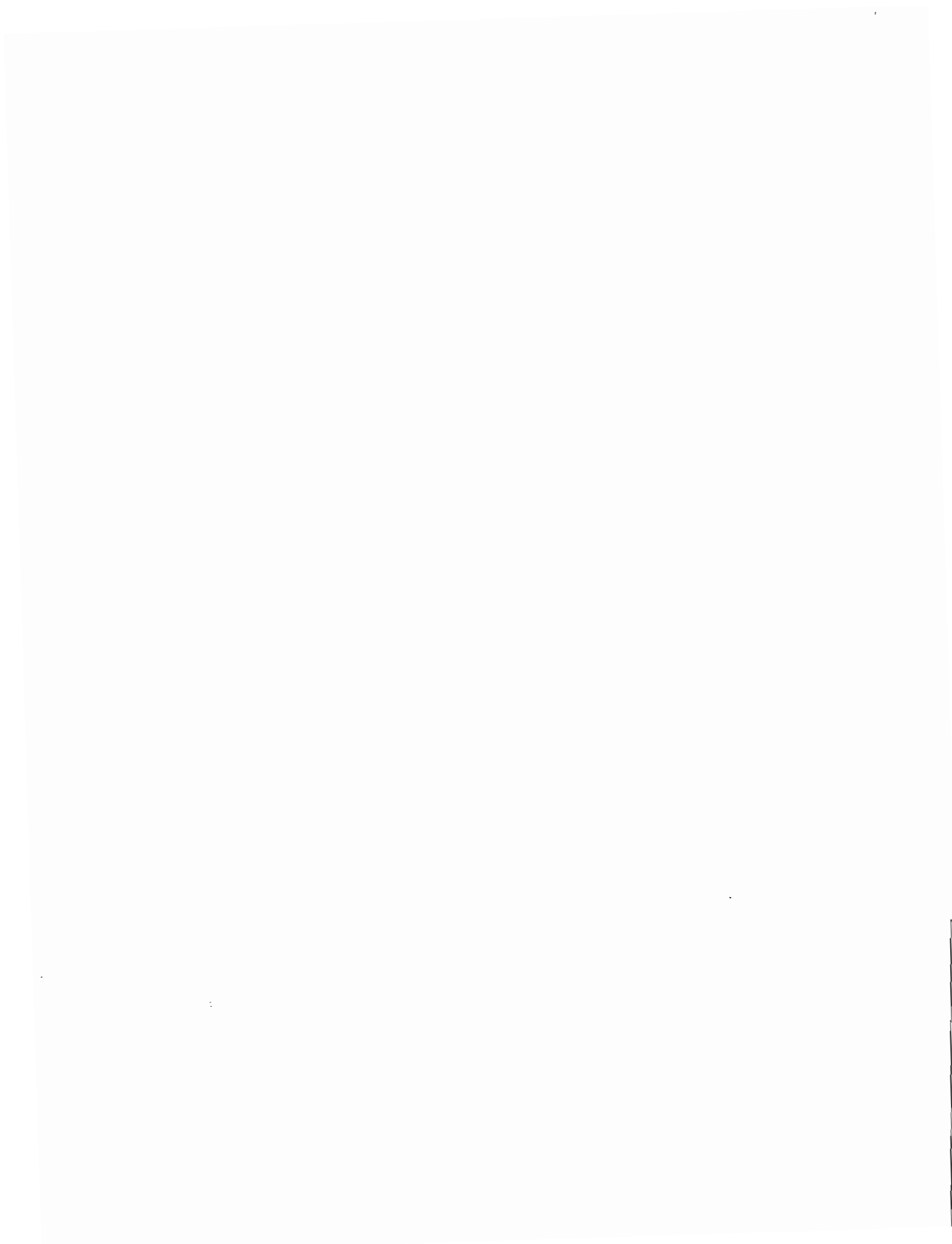

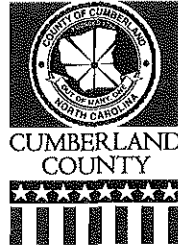

ITEM NO. 2L

COMMUNITY DEVELOPMENT
245 Person Street, 2nd Floor - P.O. Box 1829 • Fayetteville, North Carolina 28302-1829
(910) 323-6112 • Fax: (910) 323-6114

MEMORANDUM FOR BOARD OF COMMISSIONERS AGENDA
APRIL 20, 2009

TO: BOARD OF COUNTY COMMISSIONERS

THRU: JUANITA PILGRIM, DEPUTY COUNTY MANAGER

FROM: THANENA S. WILSON, COMMUNITY DEVELOPMENT DIRECTOR *T.S. Wilson*

DATE: APRIL 8, 2009

SUBJECT: PUBLIC HEARING – 2009 DRAFT COMMUNITY DEVELOPMENT ANNUAL ACTION PLAN

BACKGROUND

The Community Development 2009 Annual Action Plan must be submitted to HUD by May 15, 2009. The draft 2009 Annual Action Plan has been available for a 30-day citizen's review and comment period throughout Cumberland County since April 7, 2009. All comments received regarding the plan will be addressed by the Community Development Director within 15 days of receipt and then forwarded to HUD with the Action Plan.

As part of the citizen participation process, a public hearing must be held during the comment period. The draft plan is also available for review in the office of the Clerk to the Board of Commissioners.

RECOMMENDATION AND PROPOSED ACTION

Community Development requests that the Board of County Commissioners hold a public hearing on the draft 2009 Annual Action Plan. No other action is necessary

Attachment: Draft 2009 Annual Action Plan

Celebrating Our Past... Embracing Our Future

DRAFT

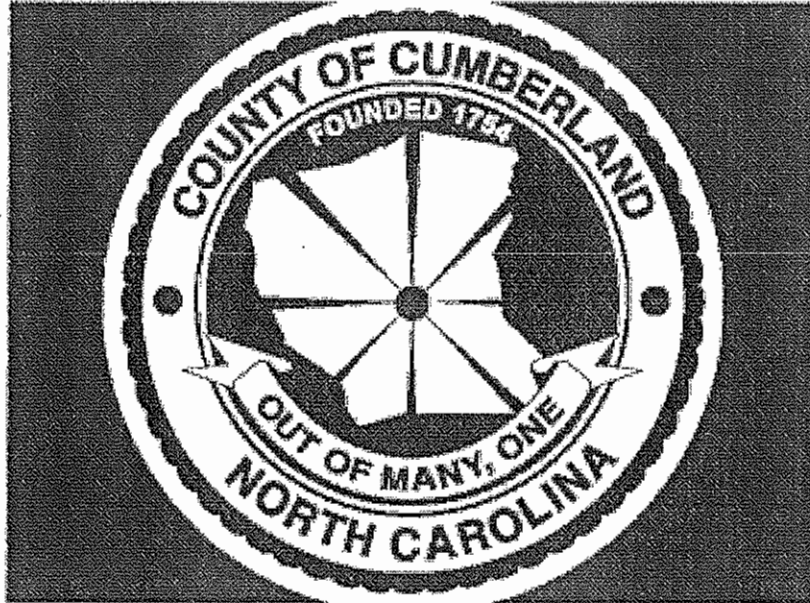

CUMBERLAND COUNTY



2009 ANNUAL ACTION PLAN

Prepared by: Cumberland County Community Development
Public Review Period: April 7, 2009 – May 6, 2009
(Public Hearing 4/20/2009)

CUMBERLAND COUNTY
2009-2010 ACTION PLAN BUDGET
 2009 PROGRAM YEAR (7/1/09 – 6/30/10)

HOUSING ACTIVITIES	CDBG	HOME
<ul style="list-style-type: none"> • Housing Rehabilitation • CHDO Set-Aside • Housing Project Delivery • Tenant Based Rental Assistance 	\$ 130,000	\$549,260
	\$228,149	\$ 82,852
		Prior Year Funds
PUBLIC FACILITIES		
<ul style="list-style-type: none"> • Debt Service for the Spring Lake Family Resource Center 	\$166,211	
ECONOMIC DEVELOPMENT		
<ul style="list-style-type: none"> • Economic Development Loans • Activity Delivery 	\$ 290,000	
	\$ 9,791	
PUBLIC SERVICES		
Agencies:	\$ 103,300	
<ul style="list-style-type: none"> • Better Health • CC MAP • CC Older Adults • City Rescue Mission • Communicare • Lisa's House of Care • Salvation Army • Robin's Meadow • Activity Delivery 	\$ 7,000	
	\$ 30,044	
ADMINISTRATION/PLANNING	\$ 241,123	\$ 64,098
TOTAL	\$1,205,618	\$696,210
REVENUE SOURCES		
GRANT FUNDS	\$1,055,618	\$490,975
PROGRAM INCOME	\$ 150,000	\$150,000
COUNTY MATCH REQUIREMENT		\$ 55,235
TOTAL	\$1,205,618	\$ 696,210

COMPETITIVE GRANT FUNDS

PROJECT	TYPE FUNDS	GRANT TERM	GRANT AWARD Estimated Balance
Robin's Meadow Transitional Housing Program	SHP	1 YR	\$84,184
County Match		4/1/09-3/31/10	\$28,046

CUMBERLAND COUNTY COMMUNITY DEVELOPMENT 2009 ANNUAL ACTION PLAN

A. PURPOSE

Cumberland County Community Development's Annual Action Plan provides a narrative description of the projects and activities that are expected to be implemented and funded with entitlement funding that Cumberland County Community Development will receive from the United States Department of Housing and Urban Development for the 2009 Program Year. The projects described on the following pages will be provided by Community Development with Community Development Block Grant (CDBG), and Home Investment Partnership Act (HOME) entitlement funds.

The 2009 Annual Action Plan strives to reflect the County's continued efforts and commitment to address Affordable Housing issues, public facility and infrastructure improvements, and the provision of homeless services as a part of the Continuum of Care for the residents of Cumberland County. Additionally, Cumberland County will continue to undertake specific actions in order to address the National Objectives outlined by the U.S. Department of Housing and Urban Development by providing for increased activity involving resident initiatives, evaluation and reduction of lead-based paint hazards, increased employment opportunities, the further development of community based institutional facilities and the enhancement of coordination between public, private housing and human service agencies.

B. GEOGRAPHIC DISTRIBUTION

The towns of Eastover, Falcon, Godwin, Hope Mills, Linden, Spring Lake, Stedman, and Wade have all elected to remain parties to Cumberland County's designation as an Urban County. All of the programs described on the following pages, with the exception of certain Public Service Program and Supportive Housing Program projects, will be accomplished in one of these municipal areas of the County or the unincorporated areas of the County.

C. SOURCES OF FUNDS

*(**Please note that actual funding allocations for the 2009-2010 Program Year have not been awarded by the U.S. Department of Housing and Urban Development as of the date of this draft publication. Therefore, 2008-2009 figures have been used for planning purposes.)*

FEDERAL SOURCES: The following information describes the sources and amounts that will be made available to Cumberland County for the implementation of 2009-2010 program goals and objectives:

Entitlement Grants

Source: Community Development Block Grant (CDBG) - Amount \$1,055,618

Source: Home Investment Partnership Act (HOME) - Amount \$490,975

Local Sources

Matching Requirements - As a federal requirement, Cumberland County is to provide matching funds for the HOME entitlement program in the amount of \$55,235.

Program Income

Cumberland County Community Development projects that it will receive program income from repayment of loans for the housing rehabilitation, homebuyer assistance, and economic development programs:

- CDBG Entitlement Program: \$150,000
- HOME Entitlement Program: \$150,000

Community Development Block Grant, Home Investment Partnership Act [including American Dream Down payment Initiative (ADDI)] Funds, local sources match, and program income will be used to address priority needs identified in the Consolidated Plan by conducting the following eligible activities:

D. DESCRIPTION OF PROJECTS

1. HOUSING ACTIVITIES:

- a. **Housing Rehabilitation Program - Housing Goal 1, Housing Goal 4 - CDBG: \$130,000. National Objective: Low/Mod Housing, Eligibility Citation: 24 CFR Part 570.202; HOME: \$549,260. Eligibility Citation: 24 CFR Part 92.205(a)(1);**

1) Owner-Occupied Rehabilitation: This program will address housing repair needs of households whose annual income is at or below 80% of the median income for Cumberland County based on household size (\$49,300 for a family of four). Households in need of repairs to meet Minimum Housing Code Standards and general property improvements will receive a deferred payment loan, with household re-certification every five years. Housing rehabilitation repairs that do not exceed \$7,500 will be given in the form of a grant. Applications for this program are accepted on an on-going basis.

2) Rental Rehabilitation (Investor-Owner): Property owners with 10 or fewer units are able to access low-interest housing rehabilitation loans for rental property. The types of repairs to be addressed are those items that do not meet Minimum Housing Code Standards and general property improvements. Loan terms are as follows:

- 3% amortized loan for 15 years (standard rehabilitation, refinance/rehabilitation, or acquisition/rehabilitation)
- 5% amortized loan for 30 years (refinance/rehabilitation or acquisition/rehabilitation).

Property owners are required to lease to renters with incomes at or below 80% of the median income for Cumberland County. Applications for this program are accepted on an on-going basis.

3. Purchase/ Rehab / Resale: This program establishes a mechanism that may be used to acquire properties for future development as affordable housing. The objectives of the program are to remove blighting conditions in low and moderate income neighborhoods, increase the county's stock of standard affordable housing units, increase the county's tax base, and create homeownership opportunities for first-time homebuyers. Properties will be acquired through donation, deed and tax sales, the foreclosure of government liens, and through private purchases. Community Development will acquire substandard single-family units, rehabilitate the units to meet Community Development Rehabilitation Standards, and then sell the units to income eligible first-time homebuyers. Community Development may also acquire vacant lots or substandard units not suitable for rehabilitation for demolition. This will allow the Department to take advantage of infill housing opportunities to further stabilize and strengthen our low and moderate-income neighborhoods through homeownership.

- b. **Homeownership Assistance Program. Priority Need: Affordable Housing; Housing Goal 2, Housing Goal 4 – HOME/ADDI: Prior years funding. Eligibility Citation: 24 CFR Part 92.205(a) (1):**

1) Down Payment/Closing Costs Assistance (DAP). This program coordinates with local financial institutions in order to provide up to \$10,000 to first time homebuyers for down payment and/or closing costs. Applicants must meet income requirements (earning no more than 80% of the median income) as well as attend a class on homeownership. Applications for this program are accepted on an on-going basis.

2) Gap Financing (GAP). CCCD will continue to offer Gap financing assistance to very low and low-income residents seeking homeownership. The amount of assistance that can be provided will not exceed \$20,000 per applicant. Such assistance will be used as a subsidy to make up the difference between the market value of the property and the sales price that is affordable to the purchaser. Applications for this program are accepted on an on-going basis.

For any of the subsidies provided, CCCD will secure a first or second mortgage on the property with an interest free 15-year (for DAP) or 30-year (for GAP) forgivable deferred loan, forgiving an equal amount of the deferred portion on the 6th anniversary of the loan and on each anniversary thereafter throughout the remainder of the loan term. The deferred payment loan is attractive because it does not add to the monthly carrying costs while permitting repayment at a future date. This approach offers the benefit of significant leverage of private lender money while providing program income for CCCD when the promissory note is triggered to be repaid. Events that would trigger early repayment of the loan would be if the borrower(s) died, ceased to occupy the property as his/her primary residence, or sold or transferred title of the property to someone else. While CCCD would partner with anyone offering an affordable mortgage product, our primary focus would be to work with those lenders whose products are most affordable.

GENERAL PROGRAM GUIDELINES

Principal Residence: The property must be occupied by the homebuyer and retained as the principal residence by the owners for the full period of affordability, which is contingent upon the amount of per unit subsidy received and may be 5, 10, or 15 years (20 if new construction). The property owner agrees to allow Cumberland County Community Development to verify principle residence status annually. Homeowner agrees to provide Community Development with a written certification of residence status to become a permanent part of the applicant file. Subletting or renting is not permitted.

Refinance: During the period of affordability, a homebuyer will not be permitted to refinance the property without the approval of Cumberland County Community Development, nor will the department agree to a subordination of its lien interest at any time.

Recapture Provision: All units receiving HOME Program subsidies are required to comply with a designated affordability period as described above. CCCD can ensure continued affordability through the recapture of its initial investment (plus interest, if debt is structured to be repaid with interest). The proceeds will be reprogrammed and used for other HOME eligible activities (i.e., assisting another eligible homebuyer in obtaining a home). Once the HOME funds are repaid, the property is no longer subject to the affordability requirements.

CCCD will make every effort to preserve affordability and avoid project default; however, in the event of a foreclosure, a transfer in lieu of foreclosure, or an assignment to HUD, the PJ must repay the HOME account. If the ownership of the housing is conveyed pursuant to a foreclosure sale, the amount of recapture due will be only the net proceeds from the sale. The recapture provisions and period of affordability on each HOME-assisted unit are enforced through the deed restrictions that are recorded as a part of each real estate closing.

Homeownership Counseling: As a requirement of the CCCD First-time Homebuyers Program, applicants are required to successfully complete a First-time Homebuyers Class prior to being awarded community development funding. CCCD contracts with a local agency qualified to provide homeownership education classes. The following services are included in the scope of services of the contract:

- Provide monthly homeownership education workshops
- Coordinate all preparation of the workshops, including advertising
- Conduct the workshop with certified housing counselors
- Provide evaluations of workshop effectiveness

Marketing: In keeping with special outreach activities outlined in CCCD's Affirmative Fair Housing Marketing Plan, certain marketing efforts (i.e. direct mailings, postings on community bulletins, PSA's, coordination with the Fayetteville Area Metropolitan Housing Authority and the Fayetteville Apartment Association, etc.) will be undertaken to ensure that residents and tenants of public and manufactured housing, and other families assisted by public housing agencies, are aware of the ADDI program.

- c. **Community Housing Development Organization (CHDO) Set-Aside. Priority Need: Affordable Housing; Housing Goal 2 - HOME: \$82,852. Eligibility Citation: 24 CFR Part 92.300**
Federal regulations require that 15% of the HOME entitlement funds be set-aside for affordable housing development by CHDOs. In order to be designated a CHDO, a non-profit organization must meet the qualifying criteria as established by HUD. CCCD continues to meet and seek qualified organizations to identify possible CHDOs.
- e. **Tenant Based Rental Assistance (TBRA). Priority Need: Affordable Housing; Housing Goal 1 – HOME: \$25,000 (prior year funding). Eligibility Citation: 24 CFR Part 92.205(a)(1)**
This program can provide rental subsidy to help eligible households afford housing costs such as rent, utility costs, security deposits, and/or utility deposits. Final program design is to be determined.
- f. **Housing Project Delivery Costs** – CCCD staff and overhead costs directly related to carrying out housing projects, such as work specifications preparation, loan processing, inspections, and other services related to assisting potential owners, tenants, and homebuyers. Staff and overhead costs directly related to providing advisory and other relocation services to persons displaced by the project, including timely written notices to occupants, referrals to comparable and suitable replacement property, property inspections, counseling and other assistance necessary to minimize hardship.

HOUSING BENCHMARKS

Housing Rehabilitation	JUL 09	AUG 09	SEP 09	OCT 09	NOV 09	DEC 09	TOTAL
Projected Expenditures	\$56,604	\$56,604	\$56,604	\$56,604	\$56,604	\$71,604	\$354,624
Units completed	3	2	3	0	2	3	13
	JAN 10	FEB 10	MAR 10	APR 10	MAY 10	JUN 10	YEARLY TOTAL
Projected Expenditures	\$54,106	\$54,106	\$54,106	\$54,106	\$54,106	\$54,106	\$679,260
Units completed	1	0	2	2	2	2	22

HOUSING BENCHMARKS (continued)

Homeownership Assistance – *(no new funds committed)	JUL 09	AUG 09	SEP 09	OCT 09	NOV 09	DEC 09	TOTAL
Projected Expenditures	*	*	*	*	*	*	*
Units completed	0	1	1	0	0	0	2
	JAN 10	FEB 10	MAR 10	APR 10	MAY 10	JUN 10	YEARLY TOTAL
Projected Expenditures	*	*	*	*	*	*	*
CHDO Set-aside	JUL 09	AUG 09	SEP 09	OCT 09	NOV 09	DEC 09	TOTAL
Projected Expenditures	TBD	TBD	TBD	TBD	TBD	TBD	TBD
Units completed	TBD	TBD	TBD	TBD	TBD	TBD	TBD
	JAN 10	FEB 10	MAR 10	APR 10	MAY 10	JUN 10	YEARLY TOTAL
Projected Expenditures	TBD	TBD	TBD	TBD	TBD	TBD	\$82,852
Units completed	TBD	TBD	TBD	TBD	TBD	TBD	TBD
Tenant Based Rental Assistance (TBRA)	JUL 09	AUG 09	SEP 09	OCT 09	NOV 09	DEC 09	TOTAL
Projected Expenditures	TBD	TBD	TBD	TBD	TBD	TBD	TBD
Clients Assisted	TBD	TBD	TBD	TBD	TBD	TBD	TBD
	JAN 10	FEB 10	MAR 10	APR 10	MAY 10	JUN 10	YEARLY TOTAL
Projected Expenditures	TBD	TBD	TBD	TBD	TBD	TBD	\$25,000
Clients Assisted	TBD	TBD	TBD	TBD	TBD	TBD	TBD
Housing Project Delivery	JUL 09	AUG 09	SEP 09	OCT 09	NOV 09	DEC 09	TOTAL
Projected Expenditures	\$19,012	\$19,012	\$19,012	\$19,012	\$19,012	\$19,012	\$114,072
Full Time Equivalent Positions	4	4	4	4	4	4	4
	JAN 10	FEB 10	MAR 10	APR 10	MAY 10	JUN 10	YEARLY TOTAL
Projected Expenditures	\$19,012	\$19,012	\$19,012	\$19,012	\$19,012	\$19,017	\$228,149
Full Time Equivalent Positions	4	4	4	4	4	4	4

2. PUBLIC FACILITIES

Public Facilities Program: Community Development Goal 1; Community Development Goal 2 - CDBG: \$166,211. National Objective: Low/Mod Income Area Benefit; Eligibility Citation: 24 CFR Part 570.201(c).

The County will continue to meet its debt service on the Section 108 Guaranteed Loan for the Spring Lake Family Resource Center.

PUBLIC FACILITIES BENCHMARKS

Section 108 Debt Service	JUL 09	AUG 09	SEP 09	OCT 09	NOV 09	DEC 09	TOTALS
Projected Expenditures	\$0	\$83,105	\$0	\$0	\$0	\$0	\$83,106
Facilities Assisted	0	1	0	0	0	0	1
	JAN 10	FEB 10	MAR 10	APR 10	MAY 10	JUN 10	TOTALS
Projected Expenditures	\$83,105	\$0	\$0	\$0	\$0	\$0	\$166,211
Facilities Assisted	1	0	0	0	0	0	1

3. ECONOMIC DEVELOPMENT

Business Loan Program: Community Development Goal 3 - CDBG: \$299,791; National Objective: Low/Mod Jobs; Eligibility Citation: 24 CFR Part 570.201(o).

Low interest business loans are offered to for-profit business that will create viable/permanent job opportunities for low to moderate-income residents. Loans are available for property acquisition, site improvements, capital equipment, machinery, and/or inventory and working capital. Loan interest rates are at 5% for a maximum term of 15 years.

Economic Development Project Delivery Costs – CCCD staff costs directly related to carrying out economic development projects, such as application intake, eligibility review; loan processing, and other technical assistance necessary to ensure program compliance.

ECONOMIC DEVELOPMENT BENCHMARKS

Economic Development Loans	JUL 09	AUG 09	SEP 09	OCT 09	NOV 09	DEC 09	TOTALS
Projected Expenditures	\$0	\$0	\$0	\$0	\$0	\$0	\$0
Businesses Assisted	0	0	0	0	0	0	0
	JAN 10	FEB 10	MAR 10	APR 10	MAY 10	JUN 10	TOTALS
Projected Expenditures	\$0	\$0	\$0	\$0	\$0	\$0	\$290,000
Businesses Assisted	0	0	1	0	0	0	1
Project Delivery	JUL 09	AUG 09	SEP 09	OCT 09	NOV 09	DEC 09	TOTALS
Projected Expenditures	\$815	\$815	\$815	\$815	\$815	\$826	\$4,901
Full-Time Equivalent Positions	.15	.15	.15	.15	.15	.15	.15
	JAN 10	FEB 10	MAR 10	APR 10	MAY 10	JUN 10	TOTALS
Projected Expenditures	\$815	\$815	\$815	\$815	\$815	\$815	\$9,791
Full-Time Equivalent Positions	.15	.15	.15	.15	.15	.15	.15

4. PUBLIC SERVICES

Public Service Program: Community Development Goal 3; Special Populations Goal 1 - CDBG: \$140,344. National Objective: Low/Mod Limited Clientele; Eligibility Citation: 24 CFR Part 570.201(e).

All projects listed under this program were pre-selected based on identified needs in the community. Final determination of funding amounts will be based on receipt of final information from each agency on the projected need to be met. The following agencies were conditionally selected for funding:

- | <u>Agency</u> | <u>Service Provided</u> |
|---|--|
| • Better Health of Cumberland County | health care assistance |
| • City Rescue Mission | shelter for homeless individuals |
| • Coordinating Council on Older Adults | at home care for the elderly |
| • Cape Fear Valley Medical Assistance Program | prescription drug assistance |
| • Robin's Meadow (CCCD) | housing & services for homeless families |
| • The Salvation Army (shelter) | shelter for homeless individuals |

Public Services Project Delivery Costs – CCCD staff costs directly related to carrying out public services projects, such as eligibility review and processing of pay requests, and other technical assistance necessary to ensure program compliance.

PUBLIC SERVICES BENCHMARKS

Better Health of Cumberland County	JUL 09	AUG 09	SEP 09	OCT 09	NOV 09	DEC 09	TOTALS
Projected Expenditures	\$1,500	\$1,500	\$1,500	\$1,500	\$1,500	\$1,500	\$9,000
Clients Assisted	35	35	35	35	35	35	210
	JAN 10	FEB 10	MAR 10	APR 10	MAY 10	JUN 10	TOTALS
Projected Expenditures	\$1,500	\$1,500	\$1,500	\$1,500	\$1,500	\$1,500	\$18,000
Clients Assisted	35	35	35	35	35	35	420
Cape Fear Valley Medical Assistance Program (CCMAP)	JUL 09	AUG 09	SEP 09	OCT 09	NOV 09	DEC 09	TOTALS
Projected Expenditures	\$1,666	\$1,666	\$1,666	\$1,666	\$1,666	\$1,670	\$10,000
Clients Assisted	66	66	66	66	66	66	396
	JAN 10	FEB 10	MAR 10	APR 10	MAY 10	JUN 10	TOTALS
Projected Expenditures	\$1,666	\$1,666	\$1,666	\$1,666	\$1,666	\$1,670	\$20,000
Clients Assisted	70	70	66	66	66	66	800

PUBLIC SERVICES BENCHMARKS (continued)

City Rescue Mission	JUL 09	AUG 09	SEP 09	OCT 09	NOV 09	DEC 09	TOTALS
Projected Expenditures	\$779	\$779	\$779	\$779	\$779	\$780	\$4,675
Clients Assisted	TBD	TBD	TBD	TBD	TBD	TBD	TBD
	JAN 10	FEB 10	MAR 10	APR 10	MAY 10	JUN 10	TOTALS
Projected Expenditures	\$779	\$779	\$779	\$779	\$779	\$780	\$9,350
Clients Assisted	TBD	TBD	TBD	TBD	TBD	TBD	TBD
Coordinating Council on Older Adults	JUL 09	AUG 09	SEP 09	OCT 09	NOV 09	DEC 09	TOTALS
Projected Expenditures	\$1,250	\$1,250	\$1,250	\$1,250	\$1,250	\$1,250	\$7,500
Clients Assisted	6	6	6	6	6	6	6
	JAN 10	FEB 10	MAR 10	APR 10	MAY 10	JUN 10	TOTALS
Projected Expenditures	\$1,250	\$1,250	\$1,250	\$1,250	\$1,250	\$1,250	\$15,000
Clients Assisted	6	6	6	6	6	6	6
Robin's Meadow	JUL 09	AUG 09	SEP 09	OCT 09	NOV 09	DEC 09	TOTALS
Projected Expenditures	0	0	0	0	0	0	0
Clients Assisted	0	0	0	0	0	0	0
	JAN 10	FEB 10	MAR 10	APR 10	MAY 10	JUN 10	TOTALS
Projected Expenditures	0	0	0	2,333	2,333	2,334	\$7,000
Clients Assisted	0	0	0	24	24	24	24
The Salvation Army (shelter)	JUL 09	AUG 09	SEP 09	OCT 09	NOV 09	DEC 09	TOTALS
Projected Expenditures	\$1,975	\$1,975	\$1,975	\$1,975	\$1,975	\$1,975	\$11,850
Clients Assisted	233	233	233	233	233	235	1,400
	JAN 10	FEB 10	MAR 10	APR 10	MAY 10	JUN 10	TOTALS
Projected Expenditures	\$1,975	\$1,975	\$1,975	\$1,975	\$1,975	\$1,975	\$23,700
Clients Assisted	233	233	233	233	233	235	2,800
Project Delivery	JUL 09	AUG 09	SEP 09	OCT 09	NOV 09	DEC 09	TOTALS
Projected Expenditures	\$2,503	\$2,503	\$2,503	\$2,503	\$2,504	\$2,504	\$15,020
Full-Time Equivalent Positions	.50	.50	.50	.50	.50	.50	.50
	JAN 10	FEB 10	MAR 10	APR 10	MAY 10	JUN 10	TOTALS
Projected Expenditures	\$2,504	\$2,504	\$2,504	\$2,504	\$2,504	\$2,504	\$30,044
Full-Time Equivalent Positions	.50	.50	.50	.50	.50	.50	.50

5. GENERAL ADMINISTRATION/PLANNING

**GENERAL ADMINISTRATION: CDBG: \$241,123, Eligibility Citation: 24 CFR Part 570.206;
HOME: \$64,098, Eligibility Citation: 24 CFR Part 92.207.**

Funds have been allocated under this activity for costs related to the administration and execution of Community Development projects under each of the entitlement programs. Eligible administrative costs may include, but not be limited to:

- a. General management, oversight, and coordination;
- b. Salaries, wages, and related costs of the participating jurisdiction's staff;
- c. Fair Housing activities;
- d. 10 Year Plan to End Homelessness activities;
- e. Monitoring progress and compliance with program requirements;
- f. Preparing reports and other documents related to the program for submission to HUD;
- g. Evaluating program results against stated objectives;
- h. Travel costs incurred for official business in carrying out the program;
- i. Administrative services performed under third party contracts or agreements;
- j. Capacity building and training for staff and non-profits; and
- k. Activities to affirmatively further fair housing.

GENERAL ADMINISTRATION BENCHMARKS

CDBG	JUL 09	AUG 09	SEP 09	OCT 09	NOV 09	DEC 09	TOTALS
Projected Expenditures	\$20,093	\$20,093	\$20,093	\$20,093	\$20,093	\$20,100	\$120,565
Full Time Equivalent Positions	5.85	5.85	5.85	5.85	5.85	5.85	5.85
	JAN 10	FEB 10	MAR 10	APR 10	MAY 10	JUN 10	TOTALS
Projected Expenditures	\$20,093	\$20,093	\$20,093	\$20,093	\$20,093	\$20,093	\$241,123
Full Time Equivalent Positions	5.85	5.85	5.85	5.85	5.85	5.85	5.85
HOME	JUL 09	AUG 09	SEP 09	OCT 09	NOV 09	DEC 09	TOTALS
Projected Expenditures	\$5,341	\$5,341	\$5,341	\$5,341	\$5,341	\$5,347	\$32,052
Full Time Equivalent Positions	1	1	1	1	1	1	1
	JAN 10	FEB 10	MAR 10	APR 10	MAY 10	JUN 10	TOTALS
Projected Expenditures	\$5,341	\$5,341	\$5,341	\$5,341	\$5,341	\$5,341	\$64,098
Full Time Equivalent Positions	1	1	1	1	1	1	1

6. COMPETITIVE GRANTS

Source: Supportive Housing Program (SHP) Amount \$84,134

The Supportive Housing Program grant funds will be used specifically to continue the implementation of several projects as a part of the Continuum of Care process for Cumberland County. Those projects include the operation of the following projects:

<u>Project</u>	<u>Project Sponsor</u>	<u>Activity</u>
ROBIN'S MEADOW*	Cumberland County Community Development	12 unit transitional housing with supportive services for homeless families
AMOUNT AWARDED: \$84,134		

*Grant Start-up: 1/99. Project renewed for additional 1 year period effective 4/1/09.

D. GEOGRAPHIC DISTRIBUTION

The towns of Eastover, Falcon, Godwin, Hope Mills, Linden, Spring Lake, Stedman, and Wade have all elected to be party to Cumberland County's designation as an Urban County. All of the programs described on the preceding pages, with the exception of certain Public Service Programs and Supportive Housing Program projects, will be accomplished in one of these municipal areas or the unincorporated areas of the County.

E. NEEDS OF PUBLIC HOUSING

Based on consultation with the Fayetteville Metropolitan Housing Authority (FMHA) during the consolidated planning process, all of the public housing developments are located outside of Cumberland County's geographic area. The only public housing properties located within our jurisdiction are scattered site single-family housing units used as a part of FMHA's Section 8 Program. The FMHA is not designated as "troubled." During the 2009 Program Year, CCCD plans to expand its marketing and outreach efforts to include coordination with the FMHA to make presentations to public housing/Section 8 program residents, specifically related to the Homebuyer Assistance Program.

F. ANTI-POVERTY STRATEGY

Throughout the development of the plan, the coordination of programs and services to assist the poorest members of our community was always a part of the development process. The long-term solution to poverty is a complex one and requires us to wrestle with social and economic issues that have persisted for decades. There is a need to alleviate the problem of excessive rent burdens for the poor by providing an increased number of available, decent, safe, and affordable housing units. Job training must be provided for skills improvement, social services with a caring heart, better education, and comprehensive health care for the indigent and more economic opportunities for people who live in Cumberland County. All of these must be components of comprehensive community planning and economic development.

The County's 2009-2010 Annual Action Plan addresses poverty issues throughout all sections of the plan. The Goals, Objectives, and Strategies in the plan were developed based on the results of citizen and agency surveys as well as consultations with local health, social service, and public housing agencies. Concerns of the poorest members of our community were considered throughout the development of the plan and are an integral part of the plan itself. Refer to Section B above for relevant goals, objectives, and strategies.

G. LEAD-BASED PAINT HAZARDS

Based on the 2000 Census, there are 118,425 housing units in Cumberland County. Approximately 55% of the County's housing stock was built prior to 1979. Lead paint is typically found in homes that were constructed prior to 1978. Lead-based paint is an environmental concern particularly in households with children seven years of age and younger. All Community Development housing rehabilitation staff has been trained in lead-based paint safe work practices and interim controls. Cumberland County Community Development will undertake the following strategies to educate and abate lead-based paint hazards:

- Develop and run periodic public service announcements to make households with children under seven aware that they may qualify for funding to assist with lead-based paint abatement;
- Ensure that all households applying for funds from CCCD's Housing Rehabilitation, Emergency Repair, or First-Time Home Buyer's Programs are given brochures on the hazards of lead-based paint; and
- Conduct workshops for new contractor so that they are trained to perform lead hazard control work as required by the Lead Safe Housing Rules.

H. OTHER ACTIONS

The following additional actions are projected to be undertaken by Cumberland County Community Development during the 2009-2010 Program year:

1. Development of Institutional Structure

- There is still an under supply of seasoned non-profit housing development organizations in Cumberland County that have hands-on experience in real estate development. A small number of private for profit developers are active in the local low-income housing tax credit market. In order, however, for Cumberland County to make advances in affordable housing, it must nurture the growth and development of non-profit developers that can access the full range of State, Federal and other subsidies needed to finance affordable housing. Non-profit organizations must develop the necessary background and experience in real estate development and affordable housing finance in order to serve the housing needs of Cumberland County over the long term.
- Cumberland County Community Development will continue to provide technical assistance to non-profit agencies through staff and the use of technical assistance funding provided by HUD.

2. Foster and Maintain Affordable Housing

- Offer affordable mortgage products through the Down payment Assistance Program (DAP) and the Gap Assistance Program (GAP).
- Partner with local lenders and the U.S. Department of Agriculture Rural Development to maximize the use of HOME funds for the Homebuyer Assistance Program.
- Acquire and renovate substandard single family units that will ultimately be sold to low to moderate income homebuyers through the Department's Buy Rehab Resale Program.
- Acquire vacant lots or substandard units not suitable for rehabilitation for demolition in order to eliminate blighting conditions in neighborhoods as well as provide additional affordable housing through the construction of housing for low to moderate income homebuyers or renters.
- To preserve affordable rental housing, offer low interest loans for rehabilitation of rental property through the Rental Rehabilitation Program.
- Seek eligible organizations for designation as Community Housing Development Organizations (CHDOs) to increase the production and supply of affordable housing.
- Low interest loans for non-profit and for-profit developers to build affordable rental and homeownership units.

3. Remove Barriers to Affordable Housing

- Interagency partnership to provide homebuyer counseling will provide increased knowledge and resources for low to moderate-income citizens seeking to purchase a home.
- Continue participation in the 10 Year planning efforts to end homeless by serving as one of the lead agency's in the community-driven process.

- Unemployment in Cumberland County is on the rise and for those who are employed, many households in the community work for low wages, which limits their housing choices and their ability to maintain their housing. Community Development will provide economic development funds, specifically geared toward job creation, to help attract higher paying industry to Cumberland County. We will continue to work with local companies as well as County Management and the other area economic development agencies in developing incentive packages to attract business to the area.
- Lack of adequate infrastructure greatly impacts the type and location of development in Cumberland County. With the use of CDBG funds, Community Development will work with the County Public Utilities Department to identify low- and moderate-income areas that may be assisted with installation of water and sewer facilities.

I. MONITORING

Cumberland County will continue to improve its established monitoring system of CDBG, HOME, and SHP housing and community development activities to ensure both short-term and long-term contract and regulatory compliance. Monitoring is the responsibility of the Cumberland County Community Development Department.

1. Subrecipient Projects:

Monitoring of sub-recipient projects has five major components:

- a. Grant Applications: Requests for funding application is made on a standard form and is carefully reviewed and evaluated. Points are given for each of 19 criteria covering community need, program effectiveness, financial record, and capacity. Recommendations for funding are based on evaluation of the above criteria.
 - b. Contractual Agreements: Cumberland County Community Development enters into a two-part contractual grant agreement with each sub-recipient. Part I of the agreement describes the tasks to be performed with the grant funds, the results to be achieved, and other conditions specific to the project. Part II lists all Federal standards with which the agency must comply. Each funded activity is assigned to the Compliance Officer. The Compliance Officer conducts pre-monitoring, desk monitoring, and on-site monitoring visits at least once a year to review for contractual and regulatory compliance.
 - c. Monitoring Records: For each sub-recipient, the staff maintain monitoring records that include the following:
 - 1) Basic information.
 - 2) Monitoring Plan - A risk assessment is carried out to determine the appropriate frequency of on-site visits, and the areas to be reviewed, including some or all of: financial management, client eligibility, program effectiveness, property, procurement, program income, fair housing and equal opportunity.
 - 3) Sub-recipient training and technical assistance provided.
 - 4) Review of the agency's CPA audit (if required).
 - 5) Quarterly financial reports and monthly draw requests from the sub-recipient.
 - 6) Quarterly programmatic reports.
 - 7) On-site monitoring reports.
 - 8) Correspondence and notes of significant telephone conversations.
2. On-Site Visits: Staff performs on-site monitoring reviews at least annually, depending on the assessment of risks for non-compliance. Program operations are observed, sub-recipient staff interviewed, client eligibility confirmed, and financial and programmatic reports verified from original documentation.

3. Long-Term Compliance: Activities involving real property acquisition or improvement require long-term compliance with the original purpose of the federal assistance. Cumberland County Community Development maintains a CDBG Real Property Inventory that is updated annually, and confirms that such property is still being used for the intended purpose. Cumberland County Community Development also carries out an annual review of HOME-assisted rental units, to ensure compliance with Housing Quality Standards, tenant eligibility, and rent ceilings.

The CCCD staff has developed detailed written guidelines for monitoring sub-recipients to ensure more uniform and comprehensive reviews. CCCD monitors the federally funded projects that are implemented by the department through a simple project tracking and management reporting system. This process includes monthly management reports, frequent inter-departmental reports and meetings, and financial reports. Project expenditures are compared with budgets on a monthly basis.

CCCD relies heavily on standard operating procedures that have been designed to be in compliance with federal standards, for example, its purchasing policy. HUD monitoring and CCCD's Single Audit provide annual independent checks on compliance by both CCCD and sub-recipients.

SPECIAL MONITORING FOR PARTICULAR ACTIVITIES

Rehabilitation 24 CFR 570.202 (Eligible Activities)

Review of File Records and Progress

Regulatory Compliance

- Location (census tract, redevelopment area)
- Type of housing (SF/MF), commercial
- Number of units per structure
- Historic preservation
- Lead-based paint (inspection/remediation)
- Household income (L/M benefit)
- Procurement and Bonding
- Labor Standards Review
- Relocation and Real Property Acquisition
- Environmental Review (date/findings)
- Project in Special Flood Hazard Area
- Section 504/ADA compliance

Comparison of Performance Records with Agreement/Application

- Scope of Work (work write-up, plans and specs, and original cost estimate)
- Contract award date, date work began
- Date final inspection; completion notice
- Number of dwelling units completed, comparison with Application/Agreement
- Actual delivery schedule v. Application and Agreement

In-House Cost and Productivity Review

- Method used to assure reasonable costs
- Direct construction costs (per unit)
- Indirect/administrative costs; comparison with cost allocation plan; percent of total
- Costs within 10% of in-house estimate
- Cost per unit v/ Budget

Community Housing Development Organizations 24 CFR Part 92 Subpart G

- .300 Set-Aside for Community Housing Development Organizations
- .301 Project-Specific Assistance to Community Housing Development Organizations

- .302 Housing Education and Organizational Support
- .303 Tenant Participation Plan

Community Housing Development Organization (CHDO) Monitoring Activities

All CHDOs will be monitored annually for recertification purposes using the following criteria:

- **Non-profit Status** – The CHDO must maintain its status as a non-profit corporation with a 501(c)(3) or 501(c)(4) IRS tax-exempt ruling.
- **Affordable Housing Commitment** – The CHDO must have a stated commitment to the development or affordable housing in the community it serves. The commitment must continue to be in at least one of the following: a) articles of incorporation, b) by-laws of the organization, c) board resolution, or d) charter.
- **Not Controlled by Public or For-profit** – The CHDO must continue to be free of external controls, either from public or for-profit interests.
- **Capacity** – The CHDO must have its own staff and must be capable of engaging in the housing development activity it intends to pursue. The CHDO must currently have adequate capacity or must have demonstrated capacity building activities.
- **Board Composition** – The CHDO's board structure must continue to reflect the community that it intends to serve and otherwise meet the regulatory requirements of the HOME program.

ON-SITE REVIEWS

Staff will perform on-site monitoring reviews at least annually, depending on the risk assessment for non-compliance. Program operations are observed, CHDO staff interviewed, client eligibility confirmed, and financial and programmatic reports verified from original documentation.

MONITORING CHDO PROJECTS

Eligible CHDO activities include: acquisition and/or rehabilitation of rental housing; new construction of rental housing; acquisition and/or rehabilitation of homebuyer property; new construction of homebuyers property; provide direct homebuyers assistance.

Monitoring activities will be conducted in accordance with Special Monitoring for Particular Activities as outlined in Item G, *Monitoring*, of the Annual Action Plan. Monitoring activities specified for rehabilitation and rental housing projects will be followed. Staff will also ensure that the Uniform Relocation Act and 49 CFR Part 24 are adhered to for acquisition projects.

**Staff will use the handbook Monitoring HOME Program Performance (HUD-2030-CPD, October 2000) as its primary guide and resource in conducting monitoring for CHDOs and all HOME program projects.

Rental Housing Monitoring Process

Project Eligibility Determination

HOME program staff should determine whether a project is eligible for HOME funding:

- Property type eligibility
- HOME subsidy limits,
- Environmental review, and
- Site and Neighborhood standards (if applicable)

Project Tracking

HOME program staff should track progress through all stages of a project's development. When a project is in the construction phase, monitoring staff should be reviewing all documents to check the following:

- Subcontractor management and review; and
- Labor standards, Davis-Bacon (if applicable)
- Section 3 (if applicable)
- Compliance with contract deadlines;
- Comparison of payment requests with eligible costs
- Completed items on work item lists or an addendum/change order.

All work should be inspected before a payment is processed. If a project appears to be experiencing difficulties, monitoring staff should perform an on-site visit.

Project Completion Review

When a project is complete, monitoring staff should make an on-site visit to monitor compliance with the following requirements:

- Property standards,
- Only eligible costs have been reimbursed,
- Construction management records,
- Lien waivers from both general contractor and all subcontractors,
- Proper data is collected to prepare women business enterprise and minority business enterprise (WBE/MBE) reports, and
- If match is being provided, the monitor should check that all proper documents have been submitted for review and calculation.

Initial Rent and Occupancy Review

Before a project reaches stabilized occupancy (95 percent or more), monitoring staff must review the Project Compliance Report and conduct an on-site visit to confirm that rent and occupancy standards have been met.

Ongoing Monitoring

Monitoring staff must review annual Project Compliance Reports and perform regular on-site visits throughout the affordability period to ensure continued compliance with:

- Rent and occupancy requirements;
- Property standards;
- Other Federal requirements (fair housing, lead-based paint, affirmative marketing, etc.).

For the PY 2009, the risk assessment is as follows:

Agency	Score	Risk Level	Main Factors Considered
United Management Blanton Green, Crosswinds Green, Golfview, Haymount Manor, Legion Crossings, Legion Manor, and Southview Green, Southview Villas, Spring Lake Green, Alfred Street, and Curtis Lane Apartments	16	High	a, b, c
City Rescue Mission	14	High	c, d, e
Terry Spell Realty Pine Ridge Manor Apts.	11	High	a, b, c
Happy Hound	9	Moderate	c
A Taste of Europe	8	Moderate	c
The Salvation Army	7	Moderate	c
Kingdom Community Development Corp.	7	Moderate	c
Blue Sky Grading	6	Low	c
Coordinating Council on Older Adults	5	Low	b
Cape Fear Valley Medical Center/Cumberland County Medication Access Program	3	Low	b
Better Health of Cumberland County	3	Low	b

Monitoring plan is subject to change if certain issues should arise during the program year.

For more information on the Annual Action Plan, contact:

Cumberland County Community Development
P.O. Drawer 1829, 245 Person Street
Fayetteville, NC 28302
Telephone: (910) 323-6112 Facsimile: (910) 323-6114

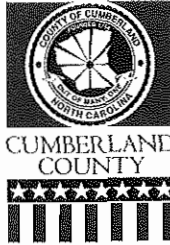

ITEM NO. 3

OFFICE OF THE COUNTY ATTORNEY

Courthouse, 117 Dick Street – Suite 551 • P.O. Box 1829 • Fayetteville, North Carolina 28302-1829
(910) 678-7762 • Fax: (910) 678-7758

April 15, 2009

MEMORANDUM FOR BOARD OF COMMISSIONERS' APRIL 20, 2009 AGENDA

TO: BOARD OF COMMISSIONERS

FROM: GRAINGER BARRETT, COUNTY ATTORNEY *GB*

SUBJECT: CONSIDERATION OF AMENDING CHAPTER 3 OF THE CUMBERLAND COUNTY CODE TO REFER TO THE "ANIMAL SERVICES DEPARTMENT" AND THE "ANIMAL SERVICES DIRECTOR"

BACKGROUND: Chapter 3 of the Cumberland County Code currently refers to the "Animal Control department" and the "Animal Control Director." The new department director, Scottie Harris, proposes that the Board of Commissioners change those references to "Animal Services Department" and "Animal Services Director," respectively.

RECOMMENDATION: Consider whether to adopt ordinance amending Chapter 3 of the Cumberland County Code to refer to the "Animal Services Department" and "Animal Services Director," respectively.

Attch.

Celebrating Our Past... Embracing Our Future

JEANNETTE M. COUNCIL
Chairman

BILLY R. KING
Vice Chairman

J. BREEDEN BLACKWELL
KENNETH S. EDGE
MARSHALL FAIRCLOTH
JIMMY KEEFE
EDWARD G. MELVIN



MARSHA S. FOGLE
Clerk to the Board

MARIE COLGAN
Deputy Clerk

BOARD OF COMMISSIONERS

5th Floor, New Courthouse • P.O. Box 1829 • Fayetteville, North Carolina 28302-1829
(910) 678-7771 • Fax: (910) 678-7770

April 13, 2009

ITEM NO. 4A

April 20, 2009 Agenda Item

TO: Board of Commissioners
FROM: Marie Colgan, Deputy Clerk *MC*
SUBJECT: Adult Care Home Community Advisory Committee

The Adult Care Home Community Advisory Committee will have the following vacancy on May 31, 2009 :

Brenda Douglas – Replacement is requested due to non-attendance. Fill the vacancy.

I have attached the current membership and applicant list for this board.

PROPOSED ACTION: Make nomination to fill the vacancy.

Attachments

pc: Andrea Wright-Valdez
Mid-Carolina Area Agency on Aging

Celebrating Our Past... Embracing Our Future

ADULT CARE HOME COMMUNITY ADVISORY COMMITTEE
Initial Appointment 1 Year/Subsequent Term 3 Years

<u>Name/Address</u>	<u>Date Appointed</u>	<u>Term</u>	<u>Expires</u>	<u>Eligible For Reappointment</u>
Marian J. Hackett (B /F) (resigned) 4184 Ferncreek Drive Fayetteville, NC 28314 323-3060/672-2129	4/08	Initial	Apr/09 4/30/09	Yes
Toney Edwards (B/M) 3622 Clearwater Drive Fayetteville, NC 28311 822-4261/864-6262	04/08	Initial	Apr/09 4/30/09	Yes
Mary Ann Brown-Jackson 1959B James Hamner Way Fayetteville, NC 28311 822-1311/893-8151 x330 (W)	1/09	2 nd	Jan/12 1/31/12	No
Sandra Ebron (B/F) PO Box 65306 Fayetteville, NC 28306 424-3932/922-9446(C)	12/08	Initial	Dec/09 12/31/09	Yes
Herma Jean Bradley (/F) 714 Topeka Street Fayetteville, NC 28301 822-3689	6/06	1 st	June/09 6/30/09	Yes
Mexie Fields (/F) 1815 Primrose Drive Fayetteville, NC 28301 488-8432	1/06	1 st	Jan/10 1/31/10	Yes
Yvonne Booth (B/F) 4568 Turquoise Road Fayetteville, NC 28311 488-7260	8/08	Initial	Aug/09 8/31/09	Yes
Brenda Douglas (B/F) 6109 Garden Court Fayetteville, NC 28311 717/0123/677-2965 (W)	5/08	Initial	May/09 5/31/09	Yes

Adult Care Home Community Advisory Committee, page 2

<u>Name/Address</u>	<u>Date Appointed</u>	<u>Term</u>	<u>Expires</u>	<u>Eligible For Reappointment</u>
Dell Caramanno (W/F) 5578 Quietwood Place Fayetteville, NC 28304 423-2622	4/08	Initial	Apr/09 4/30/09	Yes
Jacqueline Wolfe (W/F) 1812 Manchester Street Fayetteville, NC 28303 484-8588/818-2201 (C)	3/09	Initial	Mar/10 3/31/10	Yes
Wynella A. Myers (B/F) 706 Sarazan Drive Fayetteville, NC 28303 822-5526/273-8483 (C)	8/07	1 st	Aug/10 8/31/10	Yes
Janet Pelley 18 Adams Street Ft. Bragg, NC 28307 497-4947	4/06	2 nd	April/09 4/30/09	No
John Poulos (W/M) 3025 Brechin Road Fayetteville, NC 28303 867-2622/424-4242(W)	6/06	2 nd	June/09 6/30/09	No
Sonya M. Edmonds (B/F) PO Box 58394 Fayetteville, NC 28305 485-1394/(919) 566-4676 (W)	2/09	Initial	Feb/10 2/28/10	Yes
Cassandra W. Haire (B/F) 515 Albany Street Fayetteville, NC 28301 728-0175	12/08	Initial	Dec/09 12/31/09	Yes
Kim Howard (_/F) 6018 Lakaway Drive Fayetteville, NC 28306 308-5974	4/08	1 st	Apr/11 4/30/11	Yes

CONTACT: Andrea Wright-Valdez, Regional Ombudsman, Mid-Carolina Area Agency on Aging,
P. O. Box 1510, Fayetteville, NC 28302. Phone: 323-4191, x 25, fax # 323-9330
MEETINGS: Quarterly: 3rd Monday (starting March) 10 am - various adult care homes

APPLICANTS FOR
ADULT CARE HOME COMMUNITY ADVISORY COMMITTEE

<u>NAME/ADDRESS/TELEPHONE</u>	<u>OCCUPATION</u>	<u>EDUCATIONAL BACKGROUND</u>
BRUNSON, FRANCES (B/F) 1308 DEEP CREEK ROAD FAYETTEVILLE, NC 28312 578-3825/671-5147 (W)	CASE MANAGER SOUTHEASTERN REGIONAL	LTC ASSISTED LIVING ADMIN. LICENSE, EMT
CASCASAN, RALPH T. (A/M) 910 ALEXWOOD DRIVE HOPE MILLS, NC 28348-1695 425-9704/433-1036 (W)	CIVILIAN CRASH INVESTIGATOR FAYETTEVILLE POLICE DEPT.	HS; SOME COLLEGE
FERGUSON SR., ALFONSO (B/M) 7796 PINTAIL DRIVE FAYETTEVILLE, NC 283111 401-2313/483-9916 X5551235	PROGRAM CONTROL ANALYST MANTECH INTERN'L, INC.	MASTERS – HEALTH CARE ADMIN
RODRIQUEZ, DANIEL (H/M) 2634 FRANCISCAN DRIVE FAYETTEVILLE, NC 28306 425-2746/432-9701 (W)	OPERATIONS OFFICER US ARMY, FT BRAGG	BS – HEALTH SVS MS – HEALTH SVS ADMIN

JEANNETTE M. COUNCIL
Chairman

BILLY R. KING
Vice Chairman

J. BREEDEN BLACKWELL
KENNETH S. EDGE
MARSHALL FAIRCLOTH
JIMMY KEEFE
EDWARD G. MELVIN



MARSHA S. FOGLE
Clerk to the Board

MARIE COLGAN
Deputy Clerk

BOARD OF COMMISSIONERS

5th Floor, New Courthouse • P.O. Box 1829 • Fayetteville, North Carolina 28302-1829
(910) 678-7771 • Fax: (910) 678-7770

ITEM NO. 4B

April 14, 2009

April 20, 2009 Agenda Item

TO: Board of Commissioners
FROM: Marie Colgan, Deputy Clerk *mc*
SUBJECT: Criminal Justice Partnership Advisory Board

The Criminal Justice Partnership Advisory Board has the following vacancies:

Police Chief or Designee:

Captain Charles Kimble will be filling the unexpired term of Captain David Houpp who is no longer able to fill this slot. Fill the vacancy.

At Large

William David McFadyen has resigned. Callie Gardner, Director of the Cumberland County day Reporting Center, has requested that **Kraig Brown**, fill this vacant slot (see attached).

I have attached the current membership and applicant lists for this board.

PROPOSED ACTION: Make nomination to fill the two (2) vacancies.

Attachments

pc: Elizabeth Keever, Chief District Court Judge
Callie Gardner, Day Reporting Center Director

Celebrating Our Past... Embracing Our Future

Marie Colgan

From: Lisa Greeno
Sent: Tuesday, April 14, 2009 4:10 PM
To: Marie Colgan
Subject: Criminal Justice Partnership Advisory Board

William David McFadyen At-Large member for the CJPP Advisory Board is unable to continue to serve on the CJPP Advisory Board per Callie Gardner, Director of the Cumberland County Day Reporting Center. Ms. Gardner would like to make a recommendation to the Commissioners to replace Mr. McFadyen for Kraig Brown, an applicant for the Criminal Justice Partnership Advisory Board.

Thanks,
Lisa Greeno

CRIMINAL JUSTICE PARTNERSHIP ADVISORY BOARD
3-year terms

4/09

Name/Address	<u>Date</u> Appointed	Term	Expires	<u>Eligible For</u> Reappointment
<u>Probation Officer/Assistant JDM</u>				
Jonette Quenum(/F) Div. of Community Corrections 412-A Russell Street Fayetteville, NC 28301 486-1890 (W)	6/08	2 nd	June/11 6/30/11	Yes
A. Wayne Marshburn, JDM Div. of Community Correction 412-A W. Russell Street Fayetteville, NC 28301 486-1161(W)	6/08	4 th	June/11 6/30/11	Yes
<u>Superior Court Judge</u>				
E. Lynn Johnson Cumberland County 117 Dick Street Fayetteville, NC 28301	6-07	1 st	June/10 6/30/10	Yes
<u>District Court Judge</u>				
Beth Keever (W/F) Cumberland County Courthouse 117 Dick Street Fay., NC 28301 678-2901(W)	6/06	5 th	June/09 6/30/09	Yes
<u>Police Chief or Designee</u>				
Captain David Houp Fayetteville Police Department 467 Hay Street Fay., NC 28301 433-1861	9/07	1 st	Sept/10 9/30/10	Yes
<u>Sheriff or Designee</u>				
Major John McRainey Cumberland County Sheriff's Office Law Enforcement Center 131 Dick Street Fay., NC 28301 323-1500(W)	6/08	4 th	June/11 6/30/11	Yes

CRIMINAL JUSTICE PARTNERSHIP ADVISORY BOARD PG. 2

<u>Name/Address</u>	<u>Date Appointed</u>	<u>Term</u>	<u>Expires</u>	<u>Eligible For Reappointment</u>
<u>Community-Based Corrections Programs Representative</u>				
Sue Horne (/F) Fayetteville Area Sentencing 310 Green Street, Suite 110 Fay., NC 28301 323-5852	4/09	2 nd	April/12 4/30/12	No
<u>District Attorney</u>				
Ed Grannis (W/M) Cumberland County Courthouse 117 Dick Street Fay., NC 28301 678-2915(W)	6/07	5 th	June/10 6/30/10	Yes
<u>Victim Services Programs Representative</u>				
Sharon Wright Hucks (B/F) Cumberland County District Attorney's Office Cumberland County Courthouse Fay., NC 28301 678-2915(W)	6/08	4 th	June/11 6/30/11	Yes
<u>At-Large</u>				
Leesa Jensen (W/F) 719 Ashfield Drive Fay., NC 28311 630-0253/433-1695(W)	6/07	1 st	June/10 6/30/10	Yes
Frederick H. Frimet (C/M) 1163 Bluebird Lane Fay., NC 28311 488-7486(H)	6/07	2 nd	June/10 6/30/10	No
Richard A. Hayes 332 Summertime Road Fay., NC 28303 484-0137/733-4564(W)	6/07	4 th	June/10 6/30/10	No
Carrie M. Heffney (B/F) 7665 Wilkins Drive Fay., NC 28311 488-0707/678-8351(W)	6/06	4 th	June/09 6/30/09	Yes

CRIMINAL JUSTICE PARTNERSHIP ADVISORY BOARD PG. 3

<u>Name/Address</u>	<u>Date</u> Appointed	<u>Eligible For</u> Term	<u>Expires</u>	<u>Reappointment</u>
<u>At-Large</u>				
William David McFadyen (W/M) 7122 Hunters Point Drive Fay., NC 28311 822-2362	6/07	1 st	June/10 6/30/10	Yes
Kirk Nance 603 Pilot Avenue Fay., NC 28303 484-4140/323-3500(W)	6/06	2 nd	June/09 6/30/09	No
<u>Public Defender</u>				
Ron McSwain (W/M) Cumberland County Courthouse, Suite 307 117 Dick Street Fay., NC 28301 678-2918(W)	6/07	5 th	June/10 6/30/10	Yes
<u>County Commissioner</u>				
Marshall Faircloth (W/M) P.O. Box 1829 Fay., NC 28302 678-7771(W)	2/09	1 st	June/10 6/30/10	Yes
serving unexpired term				
<u>Substance Abuse Service Representative</u>				
James Miller (W/M) 6674 Sim Cannady Road Hope Mills, NC 28348 321-6793	6/08	5 th	June/11 6/30/11	Yes
<u>Criminal Defense Attorney</u>				
David Delaney 325 Green Street Fay., NC 28301 484-9696 (W)	6/07	1 st	June/10 6/30/10	Yes

CRIMINAL JUSTICE PARTNERSHIP ADVISORY BOARD PG. 4

<u>Name/Address</u>	<u>Date Appointed</u>	<u>Term</u>	<u>Expires</u>	<u>Eligible For Reappointment</u>
<u>County Manager or Designee</u> Juanita Pilgrim (B/F) P.O. Box 1829 Fay., NC 28302 678-7723(W)	6/00	N/A	N/A	Yes

Meetings: Second Tuesday (of the last month) of Each Quarter, 5:30 PM, Cumberland County Day Reporting Center, 412 W. Russell Street, Fayetteville, NC 28301-5548

Contact: Callie Gardner, Director of Day Reporting Center (or Lisa Greeno) x6126; fax 323-6133

APPLICANTS FOR
CRIMINAL JUSTICE PARTNERSHIP ADVISORY BOARD

<u>NAME/ADDRESS/TELEPHONE</u>	<u>OCCUPATION</u>	<u>EDUCATIONAL BACKGROUND</u>
BROWN, KRAIG (B/M) 2909 WYCLIFFE COURT FAYETTEVILLE, NC 28306 964-0503/424-7678 (W)	TEACHER CUMBERLAND CO. SCHOOLS	BS.MA – CRIMINAL JUSTICE MA – HUMAN RESOURCES
FLEMING JR., DR. REV. JOE (B/M) 7235 RYAN STREET FAYETTEVILLE, NC 28314 868-1428/257-7323	RETIRED	16 YEARS
JOHNSON, LENNIE E. (W/M) 6360 SMITHFIELD WADE, NC 28395 980-1401	RETIRED – LAW ENFORCEMENT	SOME COLLEGE L.E. ACADEMY
MARSHALL, BARBARA SUMMEY (B/F) 7640 WILKINS DRIVE FAYETTEVILLE, NC 28311 488-2615/977-2303(W) ** SERVES ON BOARD OF HEALTH	NAVY RESERVE CHAPLAIN	BA – PSYCHOLOGY MA – RELIGIOUS ED. DR. OF MINISTRY
McINNIS, NEILL M. (W/M) 3039 GILLIS HILL ROAD FAYETTEVILLE NC 28306 867-7687/624-9215 (C)	INSTRUCTOR – CRIMINAL JUSTICE NC DEPT OF CORRECTIONS	AS – CRIMINAL JUSTICE
McLAMB, CHRIS (W/M) 5005 SOUTH RIVER SCHOOL RD WADE, NC 28395 483-0973/(919)716-3039 (W) **SERVES ON THE JUVENILE CRIME PREVENTION COUNCIL**	PROGRAM DIRECTOR NC DEPT OF CORRECTIONS	BA – SOCIOLOGY
McMILLAN, ROSIE G. (B/F) 1972 CULPEPPER LANE FAYETTEVILLE, NC 28304 864-0158/672-1105 (W) **SERVES ON THE WORKFORCE DEVELOPMENT BOARD**	PROJECT COORDINATOR FSU	BS – CRIMINAL JUSTICE M.A. – SOCIOLOGY
MERRITT, EDGAR F. (B/M) 1506 BOROS DRIVE FAYETTEVILLE, NC 28303 822-2976 **SERVES ON THE ADULT CARE HOME COMM ADVISORY BOARD**	RETIRED POLICE OFFICER	UNIVERSITY 1960-63
OWENS JR., HUBERT (B/M) 4836 DURANGO COURT FAYETTEVILLE, NC 28304 339-9592/(719)433-9684 **SERVES ON THE WORKFORCE DEVELOPMENT BOARD**	DISTRIBUTION WALMART DISTRIBUTION	HS; COLLEGE GRADUATE IN MAY 09

<u>NAME/ADDRESS/TELEPHONE</u>	<u>OCCUPATION</u>	<u>EDUCATIONAL BACKGROUND</u>
RAY, KARSTEN J. (-/M) 5249 SUNDOWN DRIVE FAYETTEVILLE, NC 28303 487-6347/366-6935 (W)	GOV'T CONTRACTOR PROPERTY MGT	BS – CRIMINAL JUSTICE AA – PARALEGAL STUDIES
SALLEY, LUKE (B/M) 104 UNIVERSITY AVENUE FAYETTEVILLE, NC 28301 488-9365/364-8505 (C)	ASST TO ADMINISTRATOR 1 ST PRESBYTERIAN CHURCH	BA – ECONOMICS & ACCOUNTING
TURNER, CASSANDRA (B/F) 5383 CLIPPER DRIVE HOPE MILLS, NC 28348 977-3099/425-4181 (W)	MANUFACTURING PUROLATOR FILTERS	HS; SOME COLLEGE

JEANNETTE M. COUNCIL
Chairman

BILLY R. KING
Vice Chairman

J. BREEDEN BLACKWELL
KENNETH S. EDGE
MARSHALL FAIRCLOTH
JIMMY KEEFE
EDWARD G. MELVIN



MARSHA S. FOGLE
Clerk to the Board

MARIE COLGAN
Deputy Clerk

BOARD OF COMMISSIONERS

5th Floor, New Courthouse • P.O. Box 1829 • Fayetteville, North Carolina 28302-1829
(910) 678-7771 • Fax: (910) 678-7770

ITEM NO. 4C

April 14, 2009

April 20, 2009 Agenda Item

TO: Board of Commissioners
FROM: Marie Colgan, Deputy Clerk *MC*
SUBJECT: Transportation Advisory Board

The Transportation Advisory Board has the following vacancies:

Urban Transit Provider Representative

The Transportation Advisory Board has recommended that **Wendy Nunnery** fill this position which has been vacant for quite awhile.

Emergency Medical Services Representative

Wally Ainsworth – completed second term and not eligible for reappointment. The Transportation Advisory Board has recommended that **Michael Roye** fill this position. Fill the vacancy.

I have attached the current membership list and applicant list for this board.

PROPOSED ACTION: Make nomination to fill the two (2) vacancies.

pc: Kristine Wagner, Transportation Program Coordinator
Planning & Inspections Department

Celebrating Our Past... Embracing Our Future

TRANSPORTATION ADVISORY BOARD
2 Year Term
(Staggered 2 & 3 Year Terms Initially)

<u>Name/Address</u>	<u>Date Appointed</u>	<u>Term</u>	<u>Expires</u>	<u>Eligible For Reappointment</u>
<u>City of Fayetteville Representative</u>				
Adolphus Thomas Community Relations Specialist City of Fayetteville 433 Hay Street Fayetteville, NC 28301 433-1935	12/08	1 st	Dec/10 12/31/10	Yes
<u>Urban Transit Provider Representative</u>				
Vacant (not required by State)				
<u>Mid-Carolina Council of Governments Director or Designee</u>				
Carolyn Tracy Mid-Carolina Council of Governments P.O. Box 1510 Fayetteville, North Carolina 28302-1510	11/07	2 nd	Nov/09 11/30/09	No
<u>County DSS Director or Designee</u>				
Crystal Black Cumberland County DSS P.O. Box 2429 Fayetteville, North Carolina 28302-2429	11/07	2 nd	Nov/09 11/30/09	No
<u>DSS Work First Representative</u>				
Ann Farrell Cumberland County DSS P.O. Box 2429 Fayetteville, North Carolina 28302-2429	11/07	2 nd	Nov/09 11/30/09	No
<u>Workforce Development Center Director or Designee</u>				
Geneva Mixon Workforce Development Center 410 Ray Avenue Fayetteville, North Carolina 28301	11/07	2 nd	Nov/09 11/30/09	No
<u>Vocational Rehab Representative</u>				
Tammy Jackson Vocational Rehab – Independent Living 1200 Fairmont Court Fayetteville, NC 28304 486-1717	11/08	2 nd	Nov/10 11/30/10	No

<u>Name/Address</u>	<u>Date Appointed</u>	<u>Term</u>	<u>Expires</u>	<u>Eligible For Reappointment</u>
<u>Sheltered Workshop Director or Designee</u>				
Betsy Torsell Employment Source 600 Ames Street Fayetteville, NC 28301	11/07	1 st	Nov/09 11/30/09	Yes
<u>Aging Programs Representative</u>				
Catherine VanSickle Cumberland County Coordinating Council On Older Adults 339 Devers Street Fayetteville, North Carolina 28303	11/07	2 nd	Nov/09 11/30/09	No
<u>County Mental Health Director or Designee</u>				
William H. Robinson CC Area Mental Health Center 109 Bradford Avenue Fayetteville, North Carolina 28301-5496 323-0601(W)	11/07	1 st	Nov/09 11/30/09	Yes
<u>Emergency Medical Services Representative</u>				
(vacated by Wally Ainsworth)	11/06	2 nd	Nov/08	No
<u>County Representative</u>				
Vacant (not required)				
<u>County Planning Department Director or Designee</u>				
Cecil Combs Cumberland County Planning Department P.O. Box 1829 Fayetteville, North Carolina 28302-1829 678-7606 (W)	12/08	1 st	Dec/10 12/31/10	Yes
<u>County Health Director or Designee</u>				
Terresio Pope Cumberland County Health Dept. 227 Fountainhead Lane Fayetteville, North Carolina 28301	12/08	1 st	Dec/10 12/31/10	Yes

<u>Name/Address</u>	<u>Date Appointed</u>	<u>Term</u>	<u>Expires</u>	<u>Eligible For Reappointment</u>
<u>At-Large Representatives</u>				
Charles Luther, Jr. LaFayette Council of the Blind 1509 Cardiff Drive Fayetteville, NC 28304 867-5554	11/08	2 nd	Nov/10 11/30/10	No
Dianne Grumelot Cumberland County Schools 1014 Gillespie Street Fayetteville, North Carolina 28306 678-2586	11/08	2 nd	Nov/10 11/30/10	No
Timothy Joel Strickland Mid-Carolina COG P.O. Drawer 1510 Fayetteville, NC 28302 323-4191, ext. 34(W)	11/08	2 nd	Nov/10 11/30/10	No
Ifetayo Farrakhan Dept. of Social Services 1225 Ramsey Street Fayetteville, North Carolina 28301 677-2531	11/08	1 st	Nov/10 11/30/10	Yes

**Board was created by the Commissioners on 11/6/00.

Meetings: Second Tuesday in first month of Quarter at 10:00 AM.

Location: Historic Courthouse, Courtroom #3

Contact: Kristine Wagner (Planning & Inspections) x7624, fax # 678-7601

(Terms must expire in November according to Bylaws.)

APPLICANTS FOR
TRANSPORTATION ADVISORY BOARD

<u>NAME/ADDRESS/TELEPHONE</u>	<u>OCCUPATION</u>	<u>EDUCATIONAL BACKGROUND</u>
ATKINSON, DEBORAH J. (B/F) 217 ANDOVER ROAD FAYETTEVILLE, NC 28311 822-5441/494-1288 (C)	RETIRED (STATE GOV'T)	BA – SOCIOLOGY MSW; MRC
CAMPBELL, DR. REBECCA M. (-/F) 7027 DARNELL STREET FAYETTEVILLE, NC 28314 487-1555	RETIRED JFK SPECIAL WARFARE	DOCTORATE – TEACHING & SPECIAL EDUCATION
COLLINS, RICKEY (W/M) 4876 US HWY 3015 HOPE MILLS, NC 28348 425-9990	RETIRED ELECTRICIAN NC	SOME COLLEGE ELEC. LICENSE
COMBS, CECIL P. (-/M) 5501 BIRDIE COURT HOPE MILLS, NC 28348	DEPUTY DIRECTOR, CC PLANNING & INSPECTIONS	BA – HISTORY
HERRINGDINE JR., LARRY (W/M) 3539 HARRISBURG DRIVE FAYETTEVILLE, NC 28306 425-1517/672-2066	OPS & LOGISTICS DIRECTOR FSU	BS – BUSINESS ADMIN WORKING ON MASTERS – PUBLIC ADMIN
MARSHALL, BARBARA SUMMEY (B/F) 7640 WILKINS DRIVE FAYETTEVILLE, NC 28311 488-2615/977-2303 (W)	VOLUNTEER/ADVOCATE RETIRED MILITARY **SERVES ON BOARD OF HEALTH**	MASTERS - RELIGIOUS EDUCATION
McALLISTER, MEREDITH (B/F) 553 HOLLYBERRY LANE FAYETTEVILLE, NC 28314 867-8564/222-8751 (W)	CERTIFIED PERSONAL FINANCE COUNSELOR - CONSUMER EDUCATION SERVICES	BUSINESS – UNC AT CHAPELL HILL
NUNNERY, WENDY (-/F) 2816 BEARS DEN WAY FAYETTEVILLE, NC 28301 484-8612/433-1748 (W)	PARA TRANSIT SUPERVISORY FAYETTEVILLE CITY TRANSIT	HS
OKHOMINA, DR. DON A. (B/M) 494 DUNLOE COURT FAYETTEVILLE, NC 28311 868-1618/672-2148 (W)	ASST PROFESSOR OF MANAGEMENT - FSU	BS – BUSINESS ADMIN MBA, PHD – MGT.
PICKETT-WADDELL, AUDREY (B/F) 1202-A SLEEPY HOLLOW DRIVE FAYETTEVILLE, NC 28311 224-8785/488-7461 (W)	DAY CARE LEAD TEACHER HOJACK CHILD DEV. CTR.	BA – SOCIOLOGY

TRANSPORTATION ADVISORY BOARD, Page 2

<u>NAME/ADDRESS/PHONE</u>	<u>OCCUPATION</u>	<u>EDUCATIONAL BACKGROUND</u>
THOMAS, ADOLPHUS (B/M) 9428 GOODEN DRIVE FAYETTEVILLE, NC 28314 867-0249/433-1935 (W)	COMMUNITY RELATIONS SPEC. CITY OF FAYETTEVILLE	BA – SOCIOLOGY

JEANNETTE M. COUNCIL
Chairman

BILLY R. KING
Vice Chairman

J. BREEDEN BLACKWELL
KENNETH S. EDGE
MARSHALL FAIRCLOTH
JIMMY KEEFE
EDWARD G. MELVIN



MARSHA S. FOGLE
Clerk to the Board

MARIE COLGAN
Deputy Clerk

BOARD OF COMMISSIONERS

5th Floor, New Courthouse • P.O. Box 1829 • Fayetteville, North Carolina 28302-1829
(910) 678-7771 • Fax: (910) 678-7770

ITEM NO. 5A

April 13, 2009

April 20, 2009 Agenda Item

TO: Board of Commissioners

FROM: Marie Colgan, Deputy Clerk *me*

SUBJECT: Adult Care Home Community Advisory Committee

BACKGROUND: On April 6, 2009, the Board of Commissioners nominated the following to fill one vacancy on the Adult Care Home Community Advisory Committee:

Terri Thomas (new appointment)

I have attached the current membership list for this committee.

PROPOSED ACTION: Appoint the above vacancy.

Attachment

pc: Andrea Wright-Valdez, Mid-Carolina Area Agency on Aging

Celebrating Our Past... Embracing Our Future

ADULT CARE HOME COMMUNITY ADVISORY COMMITTEE
Initial Appointment 1 Year/Subsequent Term 3 Years

<u>Name/Address</u>	<u>Date Appointed</u>	<u>Term</u>	<u>Expires</u>	<u>Eligible For Reappointment</u>
Marian J. Hackett (B /F) (resigned) 4184 Ferncreek Drive Fayetteville, NC 28314 323-3060/672-2129	4/08	Initial	Apr/09 4/30/09	Yes
Toney Edwards (B/M) 3622 Clearwater Drive Fayetteville, NC 28311 822-4261/864-6262	04/08	Initial	Apr/09 4/30/09	Yes
Mary Ann Brown-Jackson 1959B James Hamner Way Fayetteville, NC 28311 822-1311/893-8151 x330 (W)	1/09	2 nd	Jan/12 1/31/12	No
Sandra Ebron (B/F) PO Box 65306 Fayetteville, NC 28306 424-3932/922-9446(C)	12/08	Initial	Dec/09 12/31/09	Yes
Herma Jean Bradley (/F) 714 Topeka Street Fayetteville, NC 28301 822-3689	6/06	1 st	June/09 6/30/09	Yes
Mexie Fields (/F) 1815 Primrose Drive Fayetteville, NC 28301 488-8432	1/06	1 st	Jan/10 1/31/10	Yes
Yvonne Booth (B/F) 4568 Turquoise Road Fayetteville, NC 28311 488-7260	8/08	Initial	Aug/09 8/31/09	Yes
Brenda Douglas (B/F) 6109 Garden Court Fayetteville, NC 28311 717/0123/677-2965 (W)	5/08	Initial	May/09 5/31/09	Yes

Adult Care Home Community Advisory Committee, page 2

<u>Name/Address</u>	<u>Date Appointed</u>	<u>Term</u>	<u>Expires</u>	<u>Eligible For Reappointment</u>
Dell Caramanno (W/F) 5578 Quietwood Place Fayetteville, NC 28304 423-2622	4/08	Initial	Apr/09 4/30/09	Yes
Jacqueline Wolfe (W/F) 1812 Manchester Street Fayetteville, NC 28303 484-8588/818-2201 (C)	3/09	Initial	Mar/10 3/31/10	Yes
Wynella A. Myers (B/F) 706 Sarazan Drive Fayetteville, NC 28303 822-5526/273-8483 (C)	8/07	1 st	Aug/10 8/31/10	Yes
Janet Pelley 18 Adams Street Ft. Bragg, NC 28307 497-4947	4/06	2 nd	April/09 4/30/09	No
John Poulos (W/M) 3025 Brechin Road Fayetteville, NC 28303 867-2622/424-4242(W)	6/06	2 nd	June/09 6/30/09	No
Sonya M. Edmonds (B/F) PO Box 58394 Fayetteville, NC 28305 485-1394/(919) 566-4676 (W)	2/09	Initial	Feb/10 2/28/10	Yes
Cassandra W. Haire (B/F) 515 Albany Street Fayetteville, NC 28301 728-0175	12/08	Initial	Dec/09 12/31/09	Yes
Kim Howard (W/F) 6018 Lakaway Drive Fayetteville, NC 28306 308-5974	4/08	1 st	Apr/11 4/30/11	Yes

CONTACT: Andrea Wright-Valdez, Regional Ombudsman, Mid-Carolina Area Agency on Aging,
P. O. Box 1510, Fayetteville, NC 28302. Phone: 323-4191, x 25, fax # 323-9330
MEETINGS: Quarterly: 3rd Monday (starting March) 10 am - various adult care homes

JEANNETTE M. COUNCIL
Chairman

BILLY R. KING
Vice Chairman

J. BREEDEN BLACKWELL
KENNETH S. EDGE
MARSHALL FAIRCLOTH
JIMMY KEEFE
EDWARD G. MELVIN



MARSHA S. FOGLE
Clerk to the Board

MARIE COLGAN
Deputy Clerk

BOARD OF COMMISSIONERS

5th Floor, New Courthouse • P.O. Box 1829 • Fayetteville, North Carolina 28302-1829
(910) 678-7771 • Fax: (910) 678-7770

ITEM NO. 5B

April 13, 2009

April 20, 2009 Agenda Item

TO: Board of Commissioners
FROM: Marie Colgan, Deputy Clerk *Mc*
SUBJECT: Cumberland County Home and Community Care Block Grant
Committee

BACKGROUND: On April 6, 2009, the Board of Commissioners nominated the following to fill one vacancy on the Cumberland County Home and Community Care Block Grant Committee.

Aging Service Provider: **Mary Brymer** (new appointment)

I have attached the current membership list for this Committee.

PROPOSED ACTION: Appoint the above vacancy.

Attachment

pc: Carolyn Tracy, Mid-Carolina Area Agency on Aging

Celebrating Our Past... Embracing Our Future

CUMBERLAND COUNTY
HOME AND COMMUNITY CARE BLOCK GRANT COMMITTEE
(PLANNING COMMITTEE FOR AGING SERVICES)
4 Year Term

Name/Address	<u>Date</u> Appointed	Term	Expires	<u>Eligible For</u> Reappointment
<u>Older Consumer</u>				
Elma Jorgensen 2321 Colgate Drive Fayetteville, NC 28305	1/07	1 st	Dec/10 12/31/10	Yes
Janice Lucas P.O. Box 61 Falcon, NC 28342 980-1296	1/07	2 nd	Dec/10 12/31/10	No
Mary Mack 5471 Maplewood Fayetteville, NC 28314 867-9533	4/08	1 st	April/12 4/30/12	Yes
Edwin Deaver P.O. Box 127 Hope Mills, NC 28348	5/06	1 st	May/10 5/31/10	Yes
Edith B. Melvin (B/F) 3016 Piney Mountain Drive Hope Mills, NC 28348 481-9951	4/05	1 st	April/09 4/30/09	Yes
Barbara Marshall (B/F) 7640 Wilkins Drive Fayetteville, NC 28311 488-2615/977-2303 (C)	4/08	1 st	Apr/12 4/30/12	Yes
Ethel Hennessee 647 Edgehill Road Fayetteville, NC 28314 867-8910	12/07	1 st	Dec/11 12/31/11	Yes
Annie R. Hasan 1340 McArthur Road Fayetteville, NC 28311 630-0688/482-3513 (W)	2/08	1 st	Feb/12 2/28/12	Yes

Home and Community Care Block Grant Committee, page 2

Name/Address	Date Appointed	Term	Expires	Eligible For Reappointment
<u>Aging Service Provider</u>				
Karin Simkin Department of Social Services PO Box 2429 Fayetteville, NC 28302-2429	4/05	1 st	April/09 4/30/09	Yes
Rosa Crowe PO Box 64526 Fayetteville, NC 28306 (filling an unexpired term) 424-2993	4/07	1 st	April/09 4/30/09	Yes
Sam Hutchison (resigned) Senior Health Services 101 Robeson Street, Suite 202 Fayetteville, NC 28301	4/05	2 nd	April/09 4/30/09	No
Toney McCray Bethel Adult Day Health Care 1065 Progress Street Fayetteville, NC 28306 484-8727	12/07	2 nd	Dec/11 12/31/11	No
Katherine VanSickle CCCCOA, INC. 339 Devers Street Fayetteville, NC 28303 484-0111	1/06	1 st	Dec/09 12/31/09	Yes
Tina Dicke Legal Aid of NC PO Box 1268 (filling an unexpired term) Fayetteville, NC 28302	4/07	1 st	April/09 4/30/09	Yes
Judy Dawkins RSVP 739 Blue Street Fayetteville, NC 28301 433-1136	1/07	2 nd	Dec/10 12/31/10	No
Patricia Edwards Hope Mills Sunshine Center 3226 Davis Street Hope Mills, NC 28348	1/07	2 nd	Dec/10 12/31/10	No

<u>Name/Address</u>	<u>Date Appointed</u>	<u>Term</u>	<u>Expires</u>	<u>Eligible For Reappointment</u>
<u>Aging Service Provider</u>				
Kristine Wagner (W/F) 130 Gillespie Street Fayetteville, NC 28301 436-0340/678-7624 (W)	1/07	1 st	Dec/10 12/31/10	Yes
<u>Civic Representative</u>				
Crystal McNair United Way of Cumberland Co. PO Box 303 Fayetteville, NC 28302-0303	11/07	2 nd	Nov/11 11/30/11	No
<u>Elected Official</u>				
Richard Higgins Town of Spring Lake 1309 Mack Street Spring Lake, NC 28390 497-1027	2/07	1 st	Dec/10 12/31/10	Yes
<u>County Representatives</u>				
Amy Cannon Assistant County Manager PO Box 1829 Fayetteville, NC 28302-1829				
Juanita Pilgrim Deputy County Manager PO Box 1829 Fayetteville, NC 28302-1829				

Meets the 3rd Thursday, 2nd month of quarter, at 2 pm at various service providers within county
 Contact: Carolyn Tracy – 323-4191 x26; fax # 323-9330

JEANNETTE M. COUNCIL
Chairman

BILLY R. KING
Vice Chairman

J. BREEDEN BLACKWELL
KENNETH S. EDGE
MARSHALL FAIRCLOTH
JIMMY KEEFE
EDWARD G. MELVIN

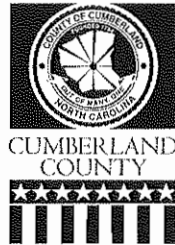

MARSHA S. FOGLE
Clerk to the Board

MARIE COLGAN
Deputy Clerk

BOARD OF COMMISSIONERS

5th Floor, New Courthouse • P.O. Box 1829 • Fayetteville, North Carolina 28302-1829
(910) 678-7771 • Fax: (910) 678-7770

April 13, 2009

ITEM NO. 50

April 20, 2009 Agenda Item

TO: Board of Commissioners
FROM: Marie Colgan, Deputy Clerk *Mc*
SUBJECT: Joint Senior Citizens Advisory Commission

BACKGROUND: On April 6, 2009, the Board of Commissioners nominated the following to fill one vacancy on the Joint Senior Citizens Advisory Commission.

Marlene Jacobs (new appointment)

I have attached the current membership list.

PROPOSED ACTION: Appoint the above vacancy.

Attachment

pc: Mary Brymer, Director
Senior Citizen Center

Celebrating Our Past... Embracing Our Future

SENIOR CITIZENS ADVISORY COMMISSION
(Joint Fayetteville/Cumberland County)
2 Year Term
(County Appointees)

<u>Name/Address</u>	<u>Date</u> <u>Appointed</u>	<u>Term</u>	<u>Expires</u>	<u>Eligible For</u> <u>Reappointment</u>
William J. Watson (B/M) 1881 Gola Drive Fayetteville, NC 28301 488-6600	2/09	1 st	Feb/11 2/28/11	Yes
Eleanor Ayers Hairr P.O. Box 220 Stedman, NC 28391 323-1892	11/08	2 nd	Nov/10 11/30/10	No
Rebecca Campbell (W/F) 7027 Darnell Street Fayetteville, NC 28314 487-1555/432-6393	10/08	1 st	Sept/10 9/30/10	Yes
Sara Jean Hicks(W/F) (resigned) 2303 Morganton Rd. #2 Fayetteville, NC 28305 417-9072/483-8309 (W)	10/08	1st	Sept/10 9/30/10	Yes
George Hatcher, Sr.(C/M) 3534 A.B. Carter Road Fayetteville, NC 28312 483-5896/818-8263(Cell)	11/08	2 nd	Nov/10 11/30/10	No
E. C. (Chip) Modlin (W/M) 2811 Millbrook Road Fayetteville, NC 28303 485-5262(H)	9/07	2 nd	Sept/09 9/30/09	No
Dineen Morton 5835 Pettigrew Drive Fayetteville, NC 28314 635-9287(W)	9/07	2 nd	Sept/09 9/30/09	No
Mary W. Rizor (W/F) 734 Baywood Road Fayetteville, NC 28312 609-1743	3/00	1st	Sept/10 9/30/10	Yes
		serving an unexpired term		

<u>Name/Address</u>	<u>Date</u> <u>Appointed</u>	<u>Term</u>	<u>Expires</u>	<u>Eligible For</u> <u>Reappointment</u>
Carolyn Tracy (W/F) 718 Southview Circle Fayetteville, NC 28311 323-4191, x26 (W)	9/08	2 nd	Sept/10 9/30/10	No
Kristine Wagner (W/F) 130 Gillespie Street Fayetteville, NC 28301 436-0340/678-7624(W)	11/08	2 nd	Nov/10 11/30/10	No

Contact: Mary Brymer – Senior Citizens Center Director – Phone: 433-1574
(Interoffice – Parks & Rec)

Commissioner Liaison: Commissioner Marshall Faircloth

Regular Meetings: 2nd Tuesday of each month at 2:30 PM
LaFayette Room – City Hall

*NOTE: This Board was expanded in 2006. The City & County agreed to expand from 10 to 20 members. The BOC had responsibility to appoint 2 new members to a 1 yr. term & 3 new members to a 2 yr. term.

JEANNETTE M. COUNCIL
Chairman

BILLY R. KING
Vice Chairman

J. BREEDEN BLACKWELL
KENNETH S. EDGE
MARSHALL FAIRCLOTH
JIMMY KEEFE
EDWARD G. MELVIN



MARSHA S. FOGLE
Clerk to the Board

MARIE COLGAN
Deputy Clerk

BOARD OF COMMISSIONERS

5th Floor, New Courthouse • P.O. Box 1829 • Fayetteville, North Carolina 28302-1829
(910) 678-7771 • Fax: (910) 678-7770

ITEM NO. 5D

April 13, 2009

April 20, 2009 Agenda Item

TO: Board of Commissioners
FROM: Marie Colgan, Deputy Clerk *MC*
SUBJECT: Mental Health Board

BACKGROUND: On April 6, 2009, the Board of Commissioners nominated the following to fill one vacancy on the Mental Health Board:

Alcoholism, Family Consumer: **Dr. Jo Beth Cain** (new appointment)

I have attached a current membership list for this board.

PROPOSED ACTION: Appoint the above vacancy.

Attachment

pc: Hank Debnam, Mental Health Department

Celebrating Our Past... Embracing Our Future

MENTAL HEALTH BOARD 1/09
 (Cumberland County Area Mental Health, Developmental Disabilities and Substance Abuse Board)
 4 Year Term (for current members as of 6-06)
 3 Year Term (for members appointed after 6-06)

<u>Name/Address</u>	<u>Date</u> <u>Appointed</u>	<u>Term</u>	<u>Expires</u>	<u>Eligible For</u> <u>Reappointment</u>
<u>Licensed Physician</u>				
Dr. Zane Walsh, Jr. (-/M) 2810 Huntington Road Fayetteville, NC 28303 484-3436/323-9010 (W)	8/08	1 st	Dec/09 12/31/09	Yes
(serving unexpired term, eligible for 2 additional full terms)				
<u>Individual with Financial Expertise</u>				
Christopher Bostock (M) 424 Kingsford Road Fayetteville, NC 28314 864-6501/486-0415(W)	12/06	1 st	Dec/09 12/31/09	Yes
Willie Cooper, Jr. (B/M) 5599 Ashgrove Drive Fayetteville, NC 28311 488-4037/829-9873 (W)	12/06	1 st	Dec/09 12/31/09	Yes
<u>Professional Rep. (Psychology, Social Work, Nursing, Religion)</u>				
Rev. Floyd Johnson, Jr. (B/M) 716 Amber Drive Fayetteville, NC 28311 822-0457	12/08	2 nd	Dec/11 12/31/11	No
<u>Representative with a Family Member or from a Citizen's Organization who Advocates for Persons with a Developmental Disability</u>				
Anna F. Finch (W/F) 3 Skye Place Fayetteville, NC 28303 485-1179	12/02	2 nd	Dec/09 12/31/09	No
<u>Drug Abuse Rep. (Family Consumer)</u>				
William H. McDougal (B/M) 661 Country Club Road Fayetteville, NC 28301 488-7311	12/07	2 nd	Dec/10 12/31/10	No
<u>Developmental Disabilities (Family Consumer)</u>				
Annie A. Owens (B/F) 186 Wolfpoint Drive Fayetteville, NC 28311 488-2028/483-0153 (W)	08/08	1 st	June/10 6/30/10	Yes
(serving unexpired term)				

Mental Health Board – page 2

<u>Name/Address</u>	<u>Date Appointed</u>	<u>Term</u>	<u>Expires</u>	<u>Eligible For Reappointment</u>
<u>Drug Abuse, Primary Consumer, Presently in Recovery</u>				
Gladys Hunt (I/F) 7158 Eagle Spring Drive Hope Mills, NC 28348 425-7409/483-8442(W) Mental Health Board, Page 2	1/06	1 st full	Dec/09 12/31/09	Yes
<u>Mental Health Rep. from a Citizens Organization or Primary Consumer</u>				
Luis M. Collazo (H/M) 2051 Merrimac Drive Fayetteville, NC 28314 864-1818/433-1697(W)	12/08	2 nd	Dec/11 12/31/11	No
<u>Mental Health Rep. (Family Consumer)</u>				
Dr. Mary A. Hales (B/F) 3490 Hastings Drive Fayetteville, NC 28311 482-3390/822-2570 (W)	1/09	1 st	Jan/12 1/31/12	Yes
<u>Alcoholism (Family Consumer)</u>				
Phyllis M. Spain (B/F) (deceased) P.O. Box 821 Spring Lake, NC 28390 484-4726/916-4974(W)	06/06 to fill unexp. term	1 st	Dec/09 12/31/09	Yes
<u>Alcoholism, Primary Consumer, Presently in Recovery</u>				
Ernest Gore (W/M) 2724 Bennington Road Fayetteville, NC 28303 822-5988/891-7062 (W)	1/09	1 st	Jan/12 1/31/12	Yes
<u>Individual with Management or Business Expertise</u>				
Liliana C. Parker (W//H/F) PO Box 58064 Fayetteville, NC 28305 433-0791/551-4611 (W)	11-07 filling unexpired term	1 st	Dec/09 12/31/09	Yes
<u>At Large Members</u>				
Evelyn O. Shaw (B/F) P.O. Box 1195 Fayetteville, NC 28302 488-3562/323-5303	05/04 to fill unexp. term	2 nd	Dec/09 12/31/09	No

Mental Health Board, page 3

<u>Name/Address</u>	<u>Date Appointed</u>	<u>Term</u>	<u>Expires</u>	<u>Eligible For Reappointment</u>
<u>Individual Representing the Interest of Children</u>				
Pam McEvoy (W/F) PO Box 488 Fayetteville, NC 28302-0488 424-0117/486-9700(W)	12/06	1 st	Dec/09 12/31/09	Yes
<u>Openly Declared Consumer with Mental Illness</u>				
Nancy Capps (I/F) 1343 Devonshire Drive Fayetteville, NC 28304	12/02	2 nd	Dec/09 12/31/09	No

Chairman Appointed Voting Member (2) – Commissioners Billy R. King & Marshall Faircloth
Contact: Hank Debnam, Mental Health Director, Ph # 222-6126, Fax # 323-0096
Meetings: 1st Wednesday of the month at 5:15 PM, 711 Executive Place, Board Room 124.

- Board expanded to 18 members 11-06-02.*
- Board terms changed to 3 year terms as of 6-06

JEANNETTE M. COUNCIL
Chairman

BILLY R. KING
Vice Chairman

J. BREEDEN BLACKWELL
KENNETH S. EDGE
MARSHALL FAIRCLOTH
JIMMY KEEFE
EDWARD G. MELVIN



MARSHA S. FOGLE
Clerk to the Board

MARIE COLGAN
Deputy Clerk

BOARD OF COMMISSIONERS

5th Floor, New Courthouse • P.O. Box 1829 • Fayetteville, North Carolina 28302-1829
(910) 678-7771 • Fax: (910) 678-7770

ITEM NO. 5E

April 13, 2009

April 20, 2009 Agenda Item

TO: Board of Commissioners
FROM: Marie Colgan, Deputy Clerk *Me*
SUBJECT: Nursing Home Advisory Board

BACKGROUND: On April 6, 2009, the Board of Commissioners nominated the following to fill one vacancy on the Nursing Home Advisory Board:

Cassandra W. Haire (new appointment)

I have attached the current membership list for this board.

PROPOSED ACTION: Appoint the above vacancy.

Attachment

pc: Andrea Wright-Valedez, Mid-Carolina Area Agency on Aging

Celebrating Our Past... Embracing Our Future

NURSING HOME ADVISORY BOARD
3 Year Term
(Initial Appointment One Year)

Name/Address	Date Appointed	Term	Expires	Eligible For Reappointment
Mandella Edwards (/F) 7076 Candlewood Drive Fayetteville, NC 28314 429-0790(H)	4/07	1 st	April/10 4/30/10	Yes
Tom Lloyd (W/M) 1306 Berkshire Road Fayetteville, NC 28305 574-3177/678-7618(W)	8/08	1 st	Aug/11 8/31/11	Yes
Martha McKoy P.O. Box 42152 Fayetteville, NC 28309 423-0771	9/08	2 nd	Sept/11 9/30/11	No
Dr. John Briggs (W/M) 2910 Hybart Street Fayetteville, NC 28303 867-1493	2/09	1 st	Feb/12 2/28/12	Yes
Terri Thomas (B/F) 508 Spaulding Street Fayetteville, NC 28301 988-7672/485-4765(W)	1/09	Initial	Jan/10 1/31/10	Yes
Hervenna Pannell (B/F) 1821 Eichelberger Drive Fayetteville, NC 28303 822-8516/907-9355(W)	2/09	2 nd	Feb/12 2/28/12	No
Clyde E. Hammond (W/M) 1802 Flintshire Road Fayetteville, NC 28304 425-2774	08/08	1 st	Aug/11 8/31/11	Yes
Elizabeth Deane (W/F) 727 Duck Court #43 Fayetteville, NC 28314 867-2873/689-0150 (W)	03/09	Initial	Mar/10 3/31/10	Yes
Toney Edwards (B/M) 3622 Clearwater Drive Fayetteville, NC 28311 822-4261/864-6262	1/09	1 st	Jan /12 1/31/12	Yes

<u>Name/Address</u>	<u>Date Appointed</u>	<u>Term</u>	<u>Expires</u>	<u>Eligible For Reappointment</u>
October Morales (W/F) 1917 Daphne Circle Fayetteville, NC 28304 (831)601-7217/689-0150 (W)	3/09	Initial	Mar/10 3/31/10	Yes
Marilynn H. Montenegro (resigned) 701 Emeline Avenue Fayetteville, NC 28303 678-8020/609-0639 (W)	12/08	Initial	Dec/09 12/31/09	Yes

CONTACT: Andrea Wright -Valdez, Mid-Carolina Area Agency on Aging
P. O. Box 1510, Fayetteville, NC 28302, (Phone: 323-4191, ext. 25)

Quarterly, 3rd Monday (March, June, September & December) at 1:00 PM - at various nursing homes in the county.

JEANNETTE M. COUNCIL
Chairman

BILLY R. KING
Vice Chairman

J. BREEDEN BLACKWELL
KENNETH S. EDGE
MARSHALL FAIRCLOTH
JIMMY KEEFE
EDWARD G. MELVIN



MARSHA S. FOGLE
Clerk to the Board

MARIE COLGAN
Deputy Clerk

BOARD OF COMMISSIONERS

5th Floor, New Courthouse • P.O. Box 1829 • Fayetteville, North Carolina 28302-1829
(910) 678-7771 • Fax: (910) 678-7770

ITEM NO. 5F

April 13, 2009

April 20, 2009 Agenda Item

TO: Board of Commissioners
FROM: Marie Colgan, Deputy Clerk *Me*
SUBJECT: Tourism Development Authority

BACKGROUND: On April 6, 2009 the Board of Commissioners nominated the following to fill one vacancy on the Tourism Development Authority:

Hotel/Motel under 100 rooms Representative: **William S. Wellons, Jr.**
(new appointment)

I have attached the current membership list for this Board

PROPOSED ACTION: Appoint the above vacancy.

Attachment

Celebrating Our Past... Embracing Our Future

TOURISM DEVELOPMENT AUTHORITY
3 Year Terms

3/08

<u>Name/Address</u>	<u>Date Appointed</u>	<u>Term</u>	<u>Expires</u>	<u>Eligible For Reappointment</u>
<u>Commissioner Appointees:</u>				
<u>Hotel/Motels under 100 rooms Representatives:</u>				
Daniel E. Roberts 3555 Braddy Road Fayetteville, NC 28306 426-1416/826-9200 (W)	4/07	1 st	April/10 4/30/10	Yes
Jimmy Keefe (resigned) 370 Echo Lane Fayetteville, NC 28303 860-7706/323-1791 x303 (W)	8/07	1 st	August/10 8/31/10	Yes
<u>Hotel/Motel over 100 rooms Representatives:</u>				
Vivek Tandon (A/M) 2857 Skye Drive Fayetteville, NC 28303 323-9070/436-1900(W)	4/07	1 st	March/10 3/31/10	Yes
Sue Wooster (W/F) 2514 Pecan Drive 425-8942/323-0011 (W)	3/08	1 st	March/11 3/31/11	Yes
<u>Member of the Public Not Affiliated with Travel/Tourism</u>				
Patricia Bush-McManus (B/F) 3472 Thorndike Drive Fayetteville, NC 28311 488-1314/484-6839(W)	3/08	1 st	March/11 3/31/11	Yes

Others:

President of the Fayetteville Area Chamber of Commerce (ex officio)

Gary Cooper
Cumberland County Business Council
P.O. Box 9
Fayetteville, NC 28302

Cumberland County Manager (ex officio)

James Martin
P.O. Box 1829
Fayetteville, NC 28302

Authority was created by the Board of Commissioners on January 28, 2002.

Board was appointed on March 11, 2002.

Meetings: Quarterly – 4th Wednesday – 8:00 AM – Room 564